

## t027 TP200-E

Precipitation Transducer, collecting area 200 cm<sup>2</sup>



SIAP+MICROS

User Manual and maintenance

## Summary

1	Introduction .....	3
2	Technical specificaion .....	4
3	Installation and maintenance .....	6
3.1	Installation .....	6
3.2	Maintenance .....	6
4	Electrical connection .....	7
4.1	Connector output .....	7
4.2	Connection cable .....	7
4.3	Data reading in serial (RS485 Modbus and SDI-12) .....	7
4.3.1	RS485 Modbus mode .....	7
4.3.2	SDI-12 mode .....	8
5	Generic information .....	9
5.1	Safety .....	9
5.2	Appropriate use of the equipment .....	10
5.3	Storage .....	10
5.4	Moving .....	10
5.5	Disposal information .....	10
6	Revision history .....	11
7	Declaration of Conformity .....	12

## 1 Introduction

---

TP200 is a tipping bucket rain gauge with a collecting area of 200 cm<sup>2</sup>. It is extremely precise, very performant and suitable also for environments where heavy rainfalls easily occur (monsoon or tropical rains). The tipping bucket consists of a v-shaped element, particularly designed to minimize friction and facilitate the oscillating action of the bucket, ensuring high standards of accuracy. The body is made of aluminium alloy and painted with a special anti-UV paint which ensures long-lasting quality and resistance to the weather events. The TP200 can be supplied in three different versions: TP200-N with impulse/reed contact output, TP200-E and TP200-12, both equipped with a specific signal conditioning electronics that reduces measurement uncertainties at high intensities of precipitation (both for intensity and amount values). TP200-E version equipped with electronic correction can give on a single connector the reed contact output (rainfall amount), the current output (intensity) and the Modbus serial output (both intensity and amount). TP200-12 version is similar to the TP200-E but it has been designed on purpose to have the SDI-12 standard communication protocol instead of Modbus. TP200-N is also available on heated version, powered at 24V (alternating or direct current). In every version, the sensor is supplied with power and signal cable (12m).

### Ordering Codes:

Reed contact output:..... t027a TP200-N

Heated version, Reed contact output: ..... t028a TP200R-N

Version with electronic correction

Available outputs: reed contact, current (or voltage), RS-485 Modbus ..... t027q TP200-E

Version with electronic correction

Available outputs: SDI-12 ..... t027r TP200-12

## 2 Technical specificaion

<b>Measurement performance</b>			
Collecting area	200 cm <sup>2</sup>		
Conversion constant	0.1 mm/impulse		
Amount resolution	0.1 mm		
Intensity resolution (TP200-E and -12)	0.1 mm/h		
Amount range	0 ÷ ∞ mm		
Intensity range (TP200-E and -12)	0 ÷ 500 mm/h		
Amount accuracy (-N)	± 2 % @ 10 ÷ 70 mm/h ± 5 % @ 70 ÷ 150 mm/h ± 7 % @ 150 ÷ 200 mm/h ± 10 % @ 200 ÷ 300 mm/h <3% (0÷500 mm/hr) by datalogger correction		
Amount accuracy (TP200-E and -12)	±1% (at 25 mm/h)		
Switch closer time	< 10 millisecond		
Lifetime of reed switch	< 1 million operations		
<b>Operating conditions</b>			
Temperature	0 ÷ 70 °C		
Temperature (heated version)	-20 ÷ 70 °C		
Rainfall intensity	0 ÷ 500 mm/h		
<b>Output</b>			
Contatto reed	0.1 mm/impulse		
RS-485 Modbus / SDI-12	Raw amount [mm], Adjusted intensity [mm/h], Adjusted amount [mm]		
Tension	0 ÷ 2 V ↔ 0 ÷ 500 mm/h		
Current	4 ÷ 20 mA ↔ 0 ÷ 500 mm/h		
<b>Power supply and Consumption</b>			
Voltage supply	7 ÷ 30 Vdc		
Heating system voltage supply (if present)	12 ÷ 24 V (DC o AC)		
Power consumption	Min	Tipico	Massimo
RS-485 Modbus / SDI-12 / 0÷2 V		1	3
4÷20 mA	5		25
<b>Mechanical specifications</b>			
Protective body	Anodized aluminium, stainless steel screws		
Trim	Thermosetting polyester-based powder paint, RAL 9003		
Dimensions	Ø 165 mm; altura 345		
Electrical connections	IP67 / 7 pole male connector		

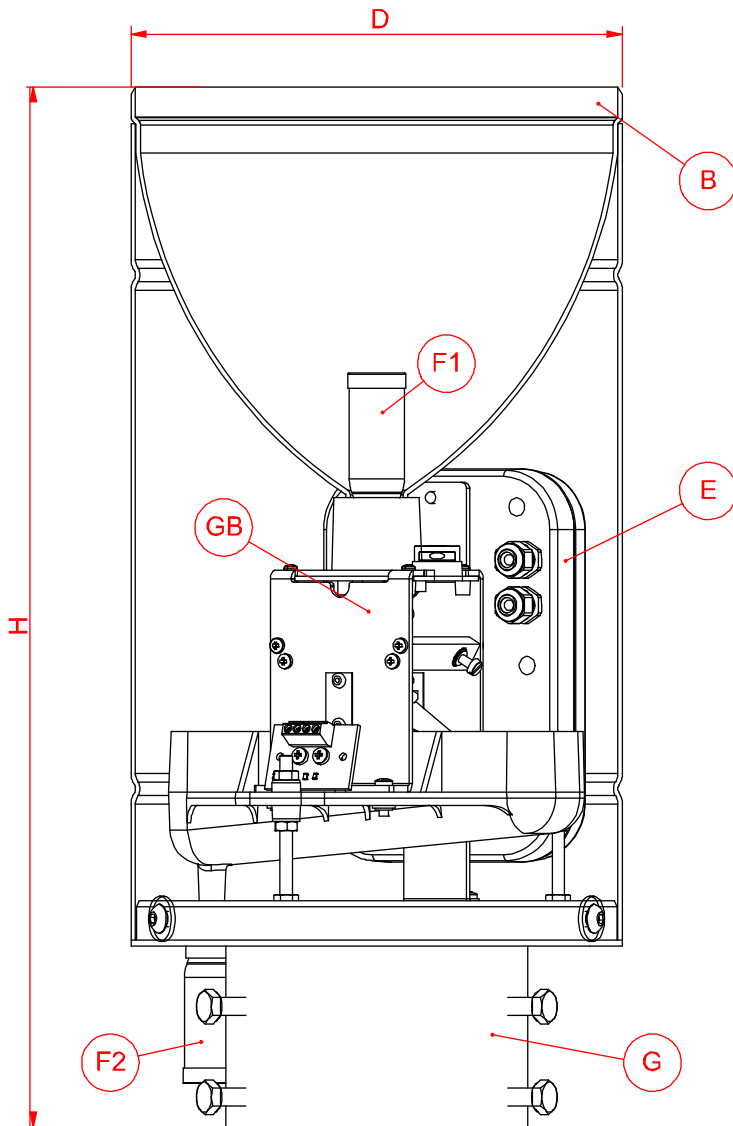

**Dimension:**

H - height: 345 mm

D - diameter: 165 mm

**Element:**

B – mouth calibrated 200 cm<sup>2</sup>

F1 – input filter

F2 – exhaust filter

GB – action group

E – management electronics (TP200 with non-natural output)

G – support shank

**Weight:** 2,2 kg

## 3 Installation and maintenance

### 3.1 Installation

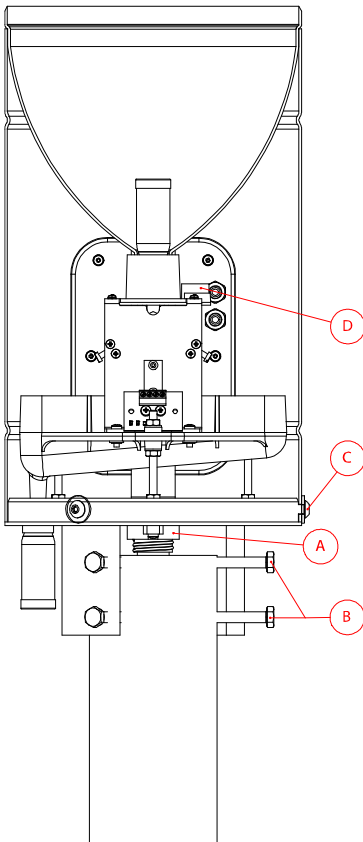

When installing a meteorological station, it is necessary to pay attention to the characteristics of the place as the conformation of the land and the proximity to any obstacles can affect the quality of the data that will be collected. In particular, it must be kept in mind that any vertical obstacle such as trees and buildings create an air turbulence equal to ten times their height. For this reason, by way of example, a weather station must maintain a minimum distance of 100 meters from 10 meter high obstacles.

The rain gauges of the TP200 family must be installed according to WMO standards, with the precipitate collection mouth at 2 metres. For their installation, two types of poles are typically used, one for burying and supported by a foundation plinth or one with a base for installation on slabs, terraces, etc.

The electrical connection is made through the cable to the connector (A) located on the lower part of the rain gauge. Mechanically, the rain gauge is installed by positioning it on the top of the support pole ( $\varnothing 70\text{mm}$ ) without the upper part, cone and mouth, which can be removed by unscrewing the 3 side fixing screws (C). Subsequently, insert the rain gauge on the pole and fix it by tightening the 6 screws on the base (B), the same screws are also used to check the horizontality of the calibrated

mouth of the rain gauge by checking the leveling with the spirit level inside (D).

Before putting the rain gauge into operation, remember to "release" the rocker from its locking elastic.

### 3.2 Maintenance

When using the TP200 rain gauges, it is necessary to pay attention to keeping the upper inlet clean to prevent any bodies from obstructing the passage of water, compromising its operation. Indeed dust, leaves, etc. can reduce the flow capacity of the water through the duct that leads to the oscillating bucket. It is advisable to clean the upper cone, the filter present on it and the one on the lower part, in pre-established periods with clean water, unscrewing it from the body of the rain gauge. Finally, it is advisable to clean the nozzle located immediately above the measuring scale with a brush.

## 4 Electrical connection

### 4.1 Connector output

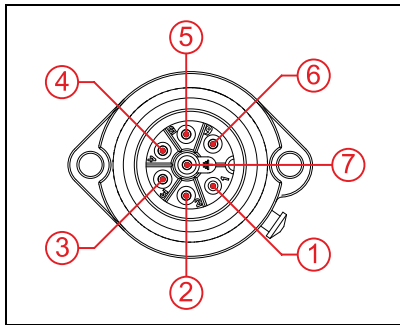
	Pin	TP200-N	TP200-E	TP200-12
	1	Contact	Contact	-
	2	Contact	Contact	-
	3	n.c.	A-RS485	SDI-12 (data)
	4	n.c.	B-RS485	n.c.
	5	n.c.	+4÷20 mA (o +0÷2 Vdc)	n.c.
	6	n.c.	Vcc	Vcc
	7	n.c.	GND	GND

### 4.2 Connection cable

The connection cable supplied with the sensor is made with circular connectors with housing, shielded 8x0.22mmq cable and ferrules for connection to the data logger terminals. The shield is connected to the black cable.

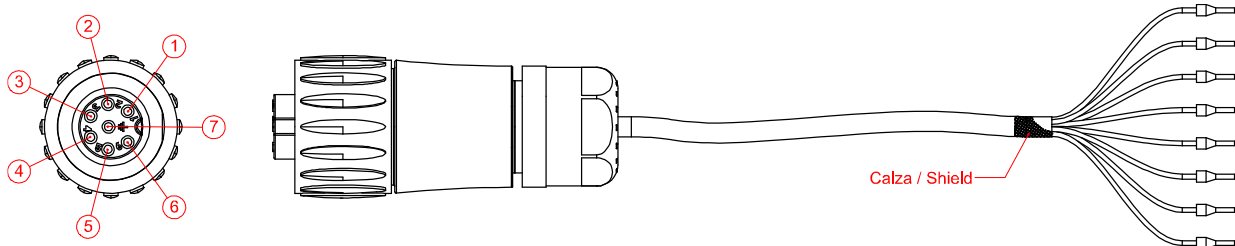

Pin	1	2	3	4	5	6	7	7
<b>Cable</b>	Red	White	Green	Black	Orange	Yellow	Blue	Brown
<b>TP200-N</b>	Contact	Contact	n.c.	n.c.	n.c.	n.c.	n.c.	n.c.
<b>TP200-E</b>	Contact	Contact	A-RS485	B-RS485	+4÷20 mA (o +0÷2 Vdc)	Vcc	GND	GND
<b>TP200-12</b>	n.c.	n.c.	SDI-12 (data)	n.c.	n.c.	Vcc	GND	GND

### 4.3 Data reading in serial (RS485 Modbus and SDI-12)

Sensors with RS485 Modbus or SDI-12 output send data only upon specific request from the PC, data logger or PLC.

Below are the correct communication parameters of the device performing the interrogation.

#### 4.3.1 RS485 Modbus mode

Serial port settings: 9600 baud, no parity, 8 data bit, 1 bit di stop

Compatible with ModBus RTU protocol, functions supported: "03 – read Holding Registers" e "04 – Read Input Registers".

Data type: "2 registers swapped float IEEE 754 in the form CDAB where A is the most significant byte of the float and D is the less significant byte of the float (swapped float)".

ID	Registers	Units	Reg. 1-2	Reg. 3-4	Reg. 5-6	Reg. 7-8	Reg. 9-10	Reg. 11-12	Reg. 13-14
17	1	mm	Total amount of rain	Rain intensity	Correct total amount of rain for intensity			Diagnostic	Supply Voltage
	3	mm/h							
	5	mm							

#### 4.3.2 SDI-12 mode

Serial port settings: 1200 baud, even parity, 7 data bits, 1 stop bit

?! Address Query

al! Send Identification

aM! Start Measurement

aC! Start Concurrent Measurement

aD0! Send Data

a	Position	Units	Decimals	Position 1	Position 2	Position 3	Position 4	Position 5	Position 6	Position 7
H	1	mm	3	Total amount of rain	Rain intensity	Correct total amount of rain for intensity	Diagnostic	Supply Voltage		
	2	mm/h								
	3	mm								

## 5 Generic information

---

The qualitative level of our instruments is the result of a continuous evolution of the product. This may cause differences between what is reported in the manual and the instrument you have purchased.

Siap+Micros S.p.A. reserves the right to modify without notice technical specifications and dimensions to adapt them to the needs of the product.

### 5.1 Safety

---

Please read these safety instructions carefully before using this product:

- The warranty will be void if the product is used differently from the instructions described in this manual.
- Any sign of tampering will void the warranty
- Use the devices only according to the instructions (environmental management, operation, wiring, installation, etc.) provided in this manual
- The correct and safe operation of the device can only be guaranteed if the transport, storage, operation and management of the device are compliant. This also applies to product maintenance.
- The device shall not be exposed to aggressive chemicals or solvents that could damage the plastic casing and/or corrode the metal parts.
- Maintenance should only be performed by qualified and well trained personnel.

It is appropriate to carry out a careful risk assessment in relation to the context of installation and use of the device by the installer considering the possible meteorological station in its complexity without being limited to the sensor.

The instruments must be installed according to the rules of the trade, with equipment that complies with applicable regulations and using supports correctly sized by qualified technicians and designed for the specific purpose.

During installation operations, check the suitability of the surrounding environment and compliance with local safety regulations.

The manufacturer declines all responsibility in case of failure due to negligence of the instructions, tampering, uses not described in this manual, improper use, use by operators not trained.

Read the instructions and intended use carefully and be sure you understand before installing the device

Before starting the activities, check the integrity of the instrument to be installed, prepare the equipment necessary for the work and wear the necessary PPE.

Take adequate measures to prevent the access of foreign personnel (untrained and uninformed) during the installation, maintenance or replacement of the instrument.

Take precautions to avoid falling objects, both during the installation phases and during the operation of the instrument.

Do not perform any activity in bad weather conditions.

During maintenance, particularly if the station is not frequented, visually check for the absence of dangerous insects and, if not, use suitable insecticides.

Consider the presence of any animals near the station, if so, pay attention to them.

Use only SIAP+MICROS original spare parts.

The instrument is not classified suitable (according to Directive 2014/34/EU) for use in atmospheres with potential explosion risk pursuant to Directive 99/92/EC.

SIAP+MICROS strives to minimize health and safety risks in all phases of the instrument's life, including installation, use, maintenance, decommissioning and disposal.

## 5.2 Appropriate use of the equipment

---

Use the instrument for its intended purpose, do not use it for any other purpose or cause malfunctions and/or damage.

## 5.3 Storage

---

If you do not plan to use the equipment for an extended period of time (at least one year) disconnect all cables from the equipment, place it in a clear plastic bag along with a bag of desiccant salts and seal the bag with tape. Put appropriate indication on the bag of the contents and weight of the equipment by inserting the wording "HANDLE WITH CARE".

Store the instrument in an environment with a temperature between 0°C and 60°C with a humidity not exceeding 80%. Make sure that the instrument is stored in a stable position and that it cannot be damaged or moved by inexperience or carelessness. Do not stack other tools or weights. Do not place the instrument on top of other instruments and in any case ensure the solidity and stability of the underlying support.

Non esporre, stoccare lo strumento in ambienti con presenza di vapori e/o gas corrosivi.

## 5.4 Moving

---

In order to avoid any damage to the device during transportation, please keep it in upright position without shaking.

## 5.5 Disposal information

---



Electrical and electronic equipment marked with specific symbol in compliance with 2012/19/EU Directive must be disposed of separately from household waste. European users can hand them over to the dealer or to the manufacturer when purchasing a new electrical and electronic equipment, or to a WEEE collection point designated by local authorities. Illegal disposal is punished by law.

Disposing of electrical and electronic equipment separately from normal waste helps to preserve natural resources and allows materials to be recycled in an environmentally friendly way without risks to human health.

## 6 **Revision history**

---

The following table shows the description of the changes made to this document.

<b>Version</b>	<b>Date</b>	<b>Updates</b>
1.0	05/06/2023	Current version of the document.

All the information content in this document are the current available at the printing phase. Siap+Micros S.p.A. reserve the rights to change the specifications without any advance notice

## 7 Declaration of Conformity



MD 751.1 rev. 03

### EU Declaration of Conformity (DoC)

**Manufacturer:** SIAP+MICROS S.p.A.  
 Via del Lavoro, 1 – 31020 S. Fior (TV) – Italy  
<https://www.siapmicros.com/en/>

This declaration of conformity is issued under the sole responsibility of the manufacturer.

**Object of the declaration:**

Description	Product Code/Model
TP200 - E Rain Gauge Transducer with 200cm <sup>2</sup> funnel area and electronic correction. Available outputs: reed contact, current, voltage and RS485-Modbus	PSM-t027q-TP200-N

The object of the declaration described above is in conformity with the relevant Union harmonization legislation:

- 2014/30/EU Electromagnetic Compatibility (EMC)
- 2011/65/EU The Restriction of Hazardous Substances Directive (RoHSD)

The following harmonised standards and technical specifications have been applied:

**EMC references:**

EN 61326-1 2021-06	Electrical equipment for measurement, control and laboratory use - EMC requirements - General requirements
-----------------------	---

**RoHSD references:**

EN 63000 2016+AMD1:2022	Technical documentation for the assessment of electrical and electronic products with respect to the restriction of hazardous substances
----------------------------	--

**Date**  
 31-01-2023

**CEO**  
 Alex Stevanin

