

T065 TX

All-in-one Sensor



User Manual Vers. 3.2

SIAP+MICROS

Contents

1	Introduction	3
1.1	Models	4
2	Technical specifications	5
3	Description	7
4	Wind speed and direction measurement.....	8
5	Installation.....	9
5.1	Alignment of the instrument.....	10
5.2	Electrical Connections.....	11
5.2.1	RS232 connection	12
5.2.2	RS485 connection	12
5.2.3	RS422 connection	13
5.2.4	SDI-12 connection	13
5.2.5	Analog outputs Connection.....	14
5.2.6	Heating connection	14
5.3	Serial output protocol.....	14
6	Configuration.....	15
6.1	Serial Commands	16
7	RS232 and RS485 ASCII proprietary modes	25
8	NMEA mode	26
9	Modbus-RTU mode.....	28
10	SDI-12 mode	32
11	Maintenance	35
12	Instrument storage	35
13	Safety instructions	35
14	Useful information.....	36

1 Introduction

The TX sensor is an all-in-one sensor which can provide accurate and reliable performance for many applications such as agriculture, sports facility, marine, construction and renewable energy. The unit can be provided in different versions according to the number of necessary sensors for the specific application.

Thanks to the different available interfaces and protocols the TX sensor ensures a great flexibility of use. Notwithstanding the high number of sensors the TX can guarantee a low power consumption which make it ideal for the installation in remote sites where only power by photovoltaic panel and battery is available.

The sensor is provided with power supply and signal cable (5m).

Measured quantities:

- Wind speed and direction, U-V Cartesian components of wind speed;
- Wind Gust;
- Relative Humidity and temperature;
- Barometric pressure;
- Global solar radiation (**optional**).

The average of wind speed and direction over a period configurable up to 10 minutes is calculated.

All models are equipped with a magnetic compass.

Wind speed and direction are determined by measuring the transit time of ultrasonic pulses between two pairs of ultrasonic transducers.

RS232, RS485, RS422 and SDI-12 serial interfaces are available with ASCII proprietary or **NMEA, Modbus-RTU** and **SDI-12** standard communication protocols.

All versions have two analog outputs, for wind speed and direction, which are factory-configurable within 4÷20 mA (standard), 0÷1 V, 0÷5 V or 0÷10 V (**to be specified when ordering**).

The **heater** option prevents the accumulation of snow and ice formation, allowing precise measurements in all environmental conditions.

Mounting on \varnothing 40 mm mast. The electric connection is performed through a M23 19-pole connector situated on the bottom of the instrument.

The low power consumption of the instrument allows installation in remote sites, with power supplied by photovoltaic panel and backup battery.

All instrument sensors are factory-calibrated and do not require additional interventions of the user (field calibration is not required).

The absence of moving parts minimizes the instrument maintenance.

1.1 Models

Sensor models:

All-in-one t065 sensor with 5 m cable:	PSM-t065a-TX
Sensor t065 All-in-one with Solar Radiation and 5 m cable:	PSM-t065b-TX

2 Technical specifications

Wind speed	
Sensor	Ultrasounds
Measuring range	0...60 m/s
Resolution	0.01 m/s
Accuracy	± 0.2 m/s or ± 2% (0...35 m/s), ± 3% (> 35 m/s)
Wind direction	
Sensor	Ultrasounds
Measuring range	0...359.9°
Resolution	0.1°
Accuracy	± 2°(over the entire range)
Compass	
Sensor	Magnetic
Measuring range	0...360°
Resolution	0.1°
Accuracy	± 1°
Air temperature	
Sensor	Pt100
Measuring range	-40...+80 °C
Resolution	0.1 °C
Accuracy	± 0.15 °C (± 0.1%)
Relative humidity	
Sensor	Capacitive
Measuring range	0...100%RH
Resolution	0.1%
Accuracy	± 2%RH
Barometric Pressure	
Sensor	Piezoresistive
Measuring range	300...1100 hPa
Resolution	0.1 hPa
Accuracy	± 0.5 hPa
Solar radiation (<i>Optional</i>)	
Sensor	Thermopile
Measuring range	0...2000 W/m ²
Resolution	1 W/m ²
Accuracy	± 3% (100 ÷ 1000W/m ²)
ISO 9060 class	Spectrally Falt Class C

General features	
Power Supply	10...30 Vdc
Power consumption	26 mA @ 24 Vdc
Serial outputs	RS232, RS485 (¼ Unit Load), RS422 and SDI-12
Communication protocols	NMEA, Modbus-RTU, SDI-12, proprietary RS232 and RS485
Analog outputs	2 analog outputs, for wind speed and direction. Output at choice among 4...20 mA (standard), 0...1 V, 0...5 V and 0...10 V (option 0...10V needs 15...30 Vdc power supply)
Wind speed averaging interval	Configurable from 1 s to 10 min
Electrical connection	19-pole M23 male connector
Operating temperature	-40...+80 °C
Protection degree	IP 66
Survival speed	90 m/s
Weight	About 1 kg About 1.5 kg (with solar radiation)
Case	Plastic material. Metal parts: AISI 316

Dimensions (mm)

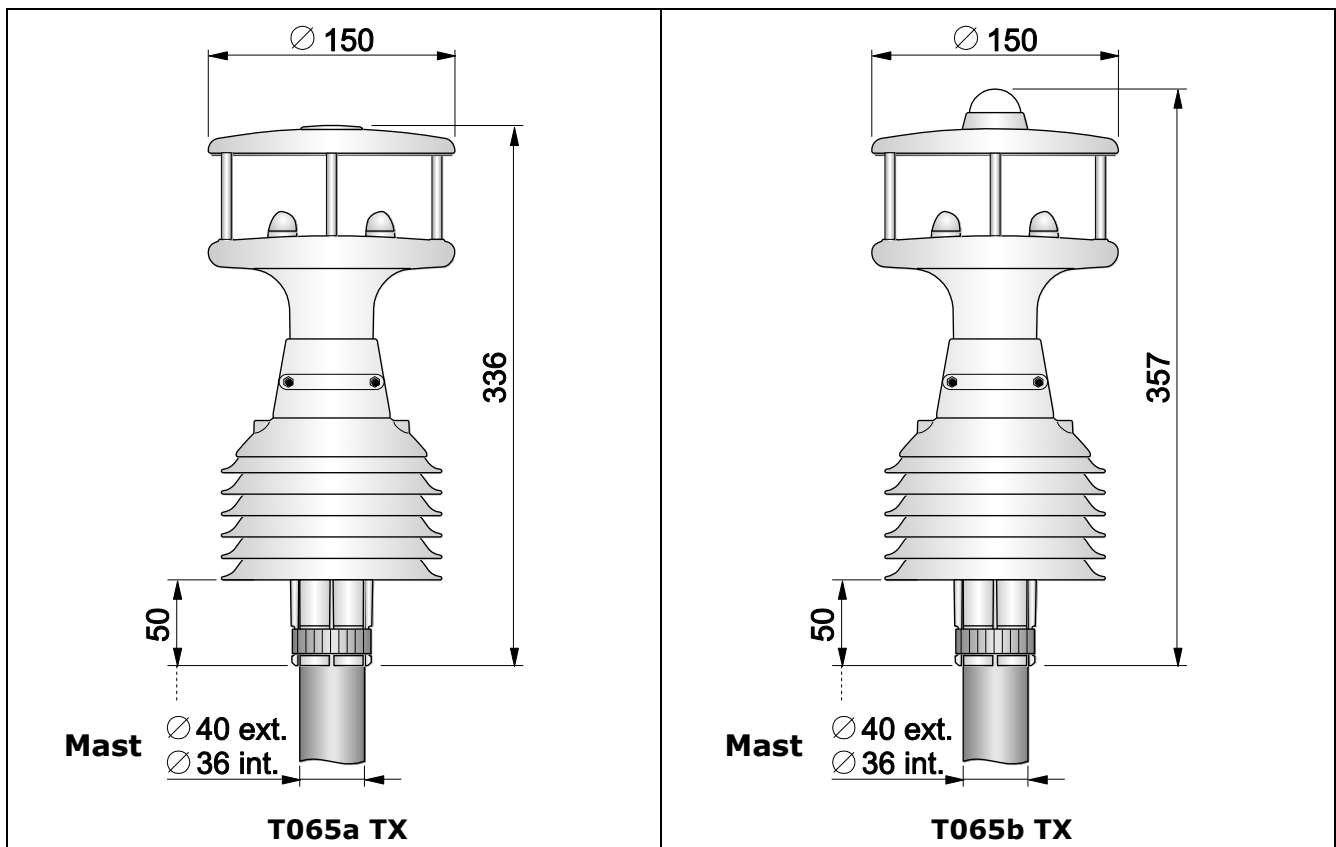

3 Description

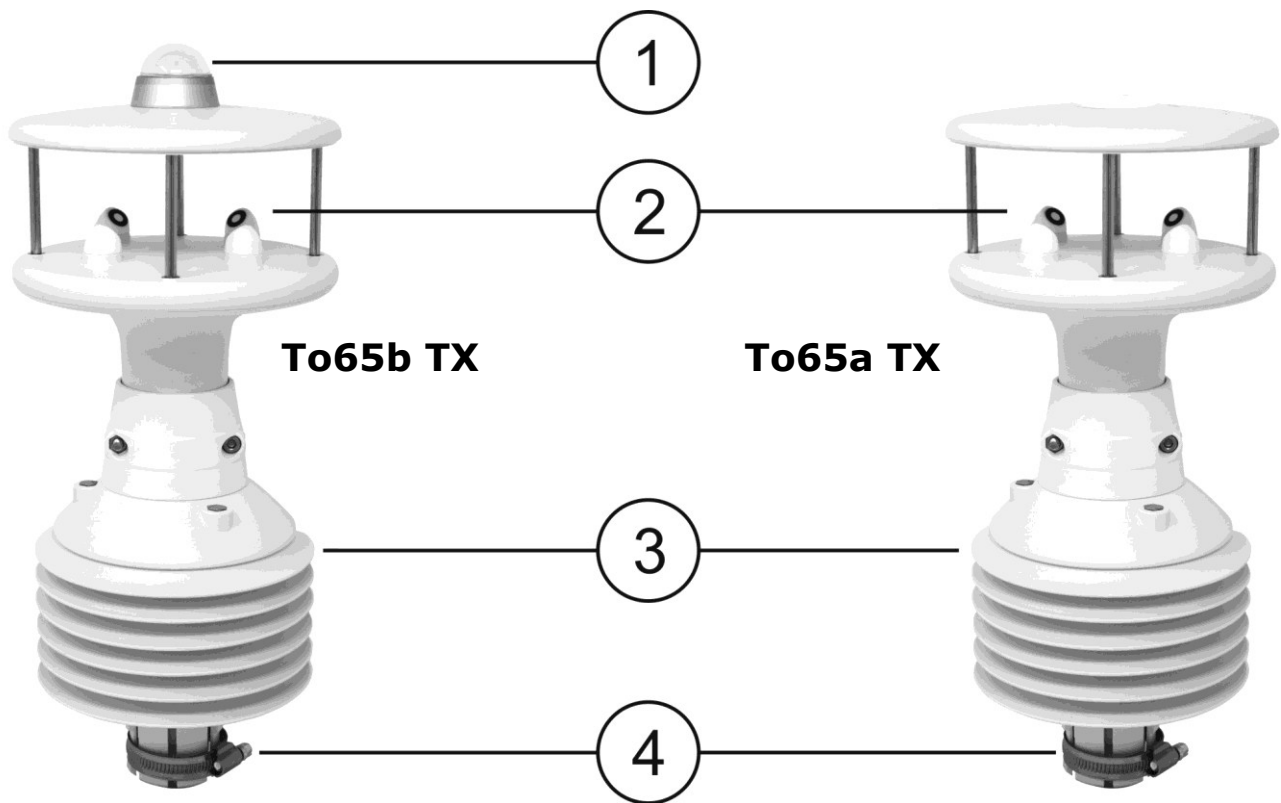

1. Pyranometer
2. Ultrasonic sensors for the measurement of wind speed and direction
3. Protective shield from solar radiation for relative humidity and temperature sensors
4. Fixing clamp to Ø 40 mm mast

Note: in the models measuring barometric pressure, the pressure sensor is inside the instrument.

4 Wind speed and direction measurement

Wind speed and direction are determined by measuring the time taken by ultrasonic pulses to cover the distance from the transducer that generates the pulse to the receiving transducer.

The instrument uses 2 pairs of transducers oriented along two orthogonal axes. Detecting the wind speed along two axes allows determining not only the intensity but also the wind direction.

The instrument measures the travel time of the ultrasonic pulse between the two transducers of the same pair in both directions. The travel times in the two opposed directions are defined as t_A (forward direction time) and t_R (reverse direction time).

If wind speed is zero, t_A and t_R values are the same. In the presence of wind, one of the two time values is greater than the other and the comparison between the two time values allows to determine the direction and the intensity of the wind.

Measuring the travel time in both directions allows to cancel the dependence of the transmission speed of ultrasounds in the air from the environmental conditions of temperature, humidity and barometric pressure.

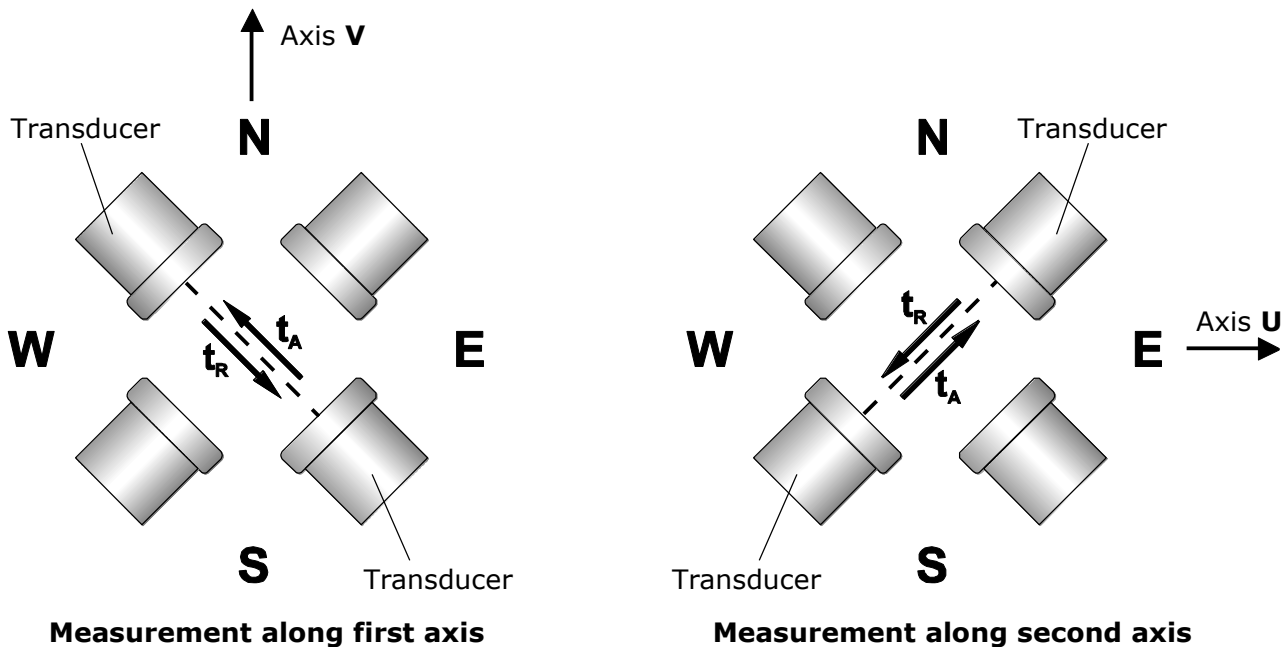

The travel times of the ultrasonic pulses are given by:

$$t_A = \frac{D}{C + V_w} \quad t_R = \frac{D}{C - V_w}$$

Where:

- D** = Distance between the two transducers of the same pair
- C** = Sound speed
- V_w** = Component of wind speed along the measurement axis

Measuring the two travel times allows determining the wind speed component:

$$V_w = \frac{D}{2} \cdot \left(\frac{1}{t_A} - \frac{1}{t_R} \right)$$

5 Installation

To install the instrument, pass the connection cable inside the support mast and connect the 19-pole M23 female connector of the cable to the 19-pole M23 male connector situated at the bottom of the instrument. Ensure connection stability by tightening the connector external nut.

Align the instrument to the desired direction (see par. 5.1), then fix it on the support mast by tightening the cable tie at the bottom of the instrument.

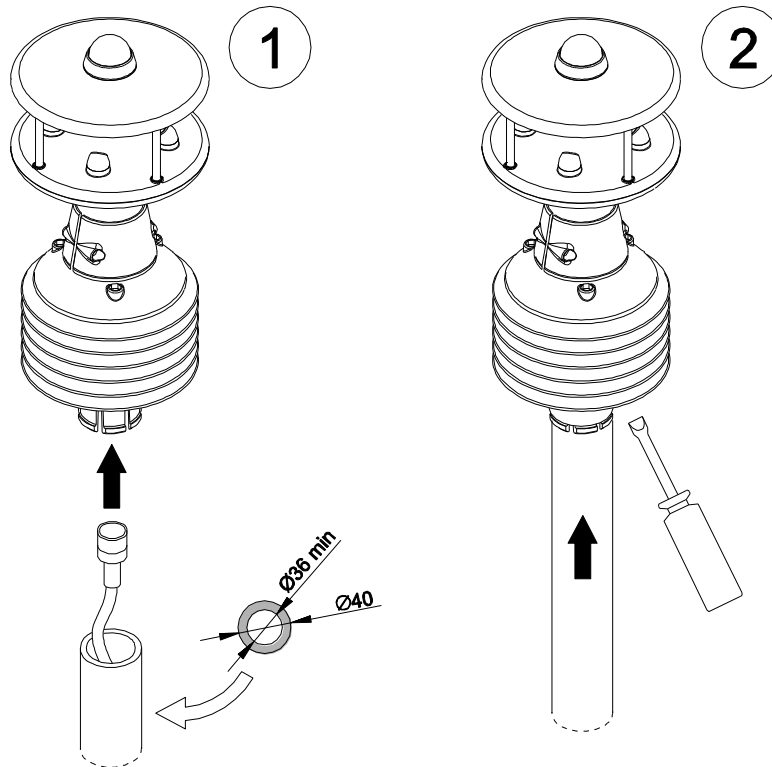

The support mast, having 40 mm maximum outer diameter and 36 mm minimum inner diameter, should be positioned on a stable surface.

The instrument should be installed vertically and in an open area, far from obstructions located in the vicinity that might alter the natural air flow. Any close objects (such as buildings, trees, pylons, etc.) should be at a distance equal to at least ten times their height.

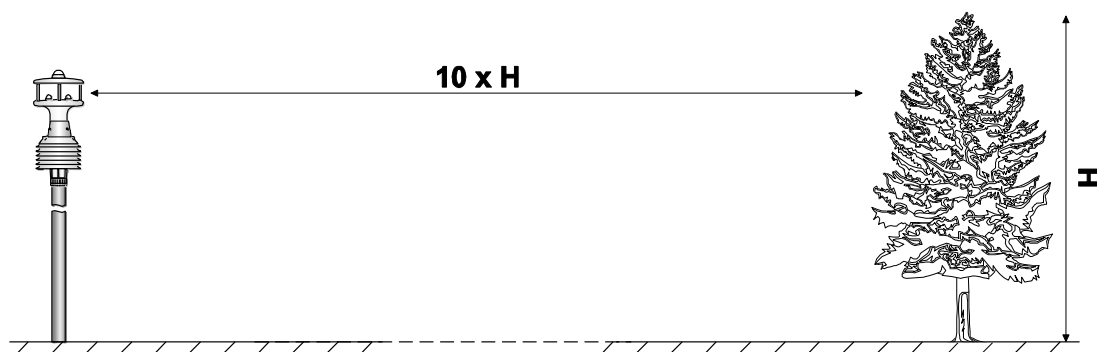

In the presence of close objects, it is advisable to place the instrument at a height of 10 m.

If the instrument is installed on a building, the height of the instrument should be at least 1.5 times the minimum value between the height of the building and the roof longest diagonal.

Mount the instrument far from magnetic materials and devices that generate magnetic fields (electric motors, electric power cables, electric transformers, radars, radio transmitters etc.) to prevent faulty indications from the magnetic compass.

In case of mobile installations (for example on a boat), consider that the instrument measures the relative (apparent) wind speed with respect to the instrument. To determine the absolute (real) wind speed one should consider the movement velocity of the instrument.

5.1 Alignment of the instrument

The instrument is equipped with a magnetic compass, and wind speed and direction measurements are automatically compensated and referred to magnetic North, even if alignment to North is not performed. This allows obtaining accurate measurements even in case of mobile installations.

It is possible to disable the compass compensation of the wind speed and direction measurements. In this case it is necessary to align the instrument during installation. The arrows on the case will facilitate the alignment.

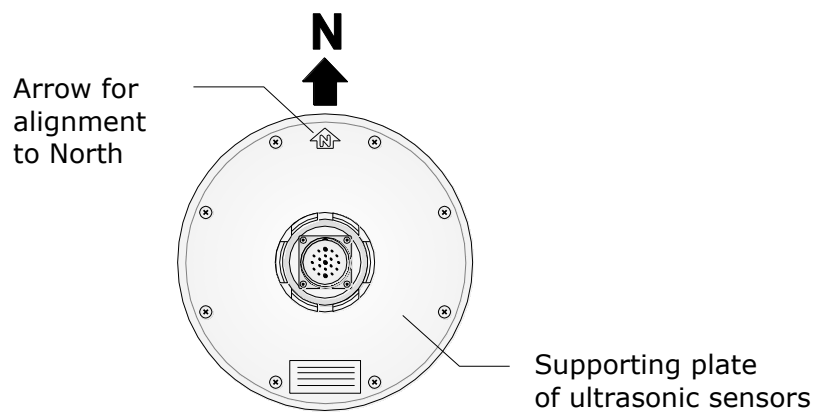

For an accurate alignment, connect the instrument to a PC (see following chapters for communication protocols), then rotate the instrument on its vertical axis until the compass measures $0.0^\circ \pm 0.1^\circ$.

When evaluating the wind direction, one should consider that the geographic North differs from the magnetic North indicated by the compass. The difference, named **magnetic declination**, depends on the area where the instrument was installed (for example, about 15° in North America and less than 3° in Europe).

If wind speed and direction values are given in polar coordinates, 0° angle corresponds to a wind coming from North.

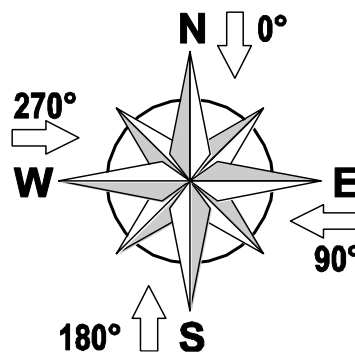

5.2 Electrical Connections

The instrument has 19-pole M23 male connector. Below are the numbering and function of the connector pins and the color correspondence with the wires of cable.

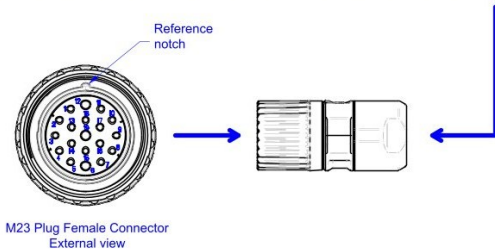
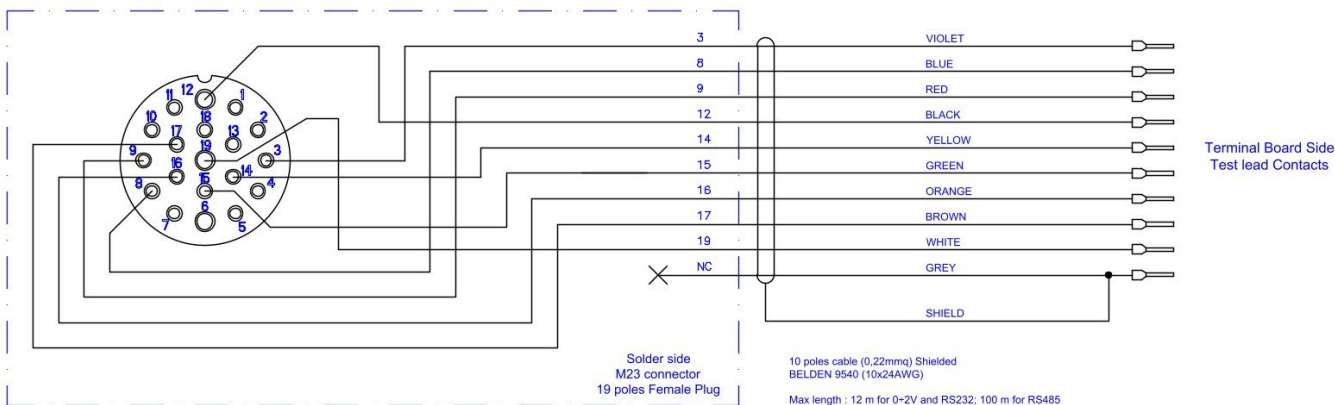
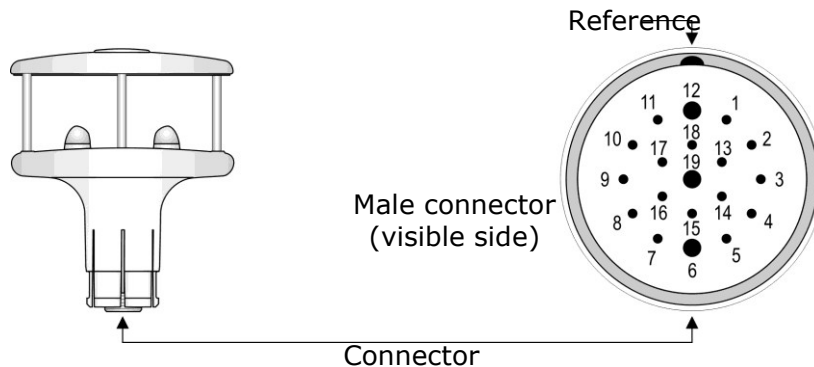

WINSON-W, WINSON-4 (t035a; t035b) All in one (t065a, t065b)										
Outputs: RS485, 0-2Vdc, RS232										
COLORS	BROWN	RED	ORANGE	YELLOW	GREEN	BLUE	VIOLET	GREY	WHITE	BLACK
SIGNALS	A RS485	B-RS485 TX-RS232	+AN.OUT 1	+AN.OUT 2	GND Analog	GND RS232	RX RS232	SHIELD	+10+30 V VCC	GND VCC

ATTENTION: in the cable version with numbered wires, the wire number does not always coincide with the M23 connector pin number.

5.2.1 RS232 connection

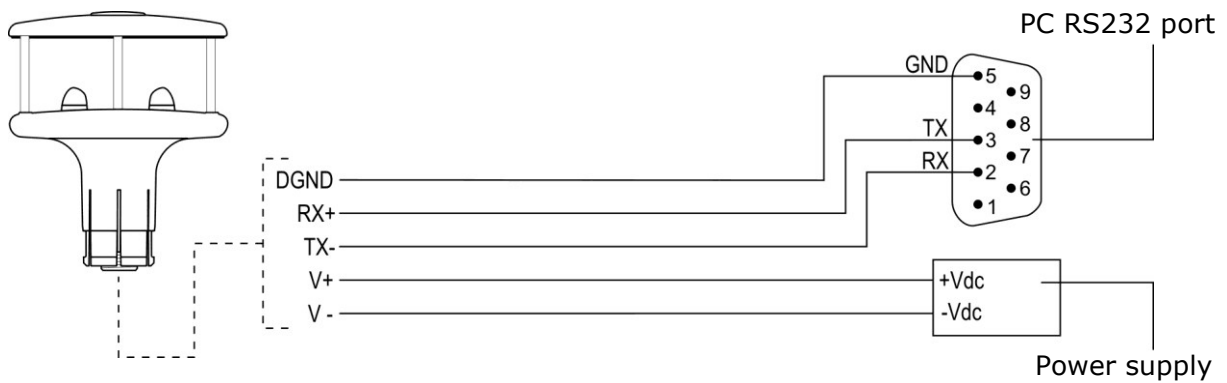

The maximum length of the RS232 connection is typically 15 m.

5.2.2 RS485 connection

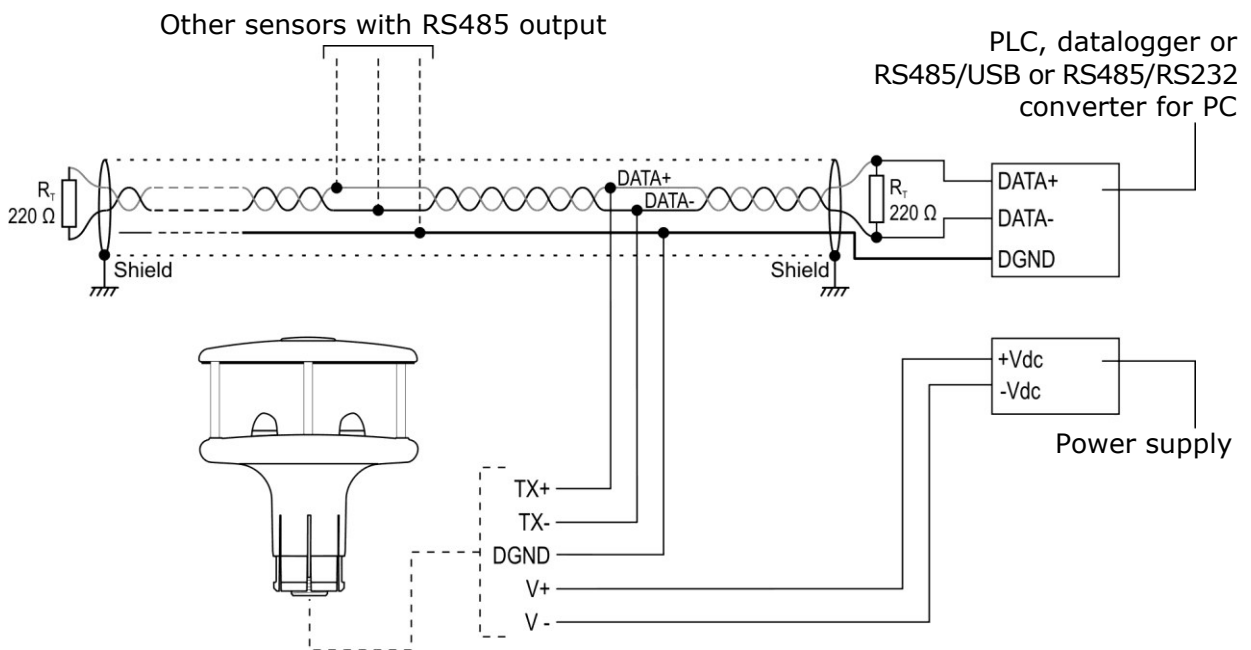

Multiple sensors can be connected in sequence through a twisted-pair shielded cable for signals and a third wire for ground.

The maximum RS485 bus length depends on baud rate and cable characteristics. Typically, using a specific RS485 cable, the maximum length is 1200 m.

Before connecting the anemometer to the network, set the address and the communication parameters, if different from the factory preset (see configuration chapter).

5.2.3 RS422 connection

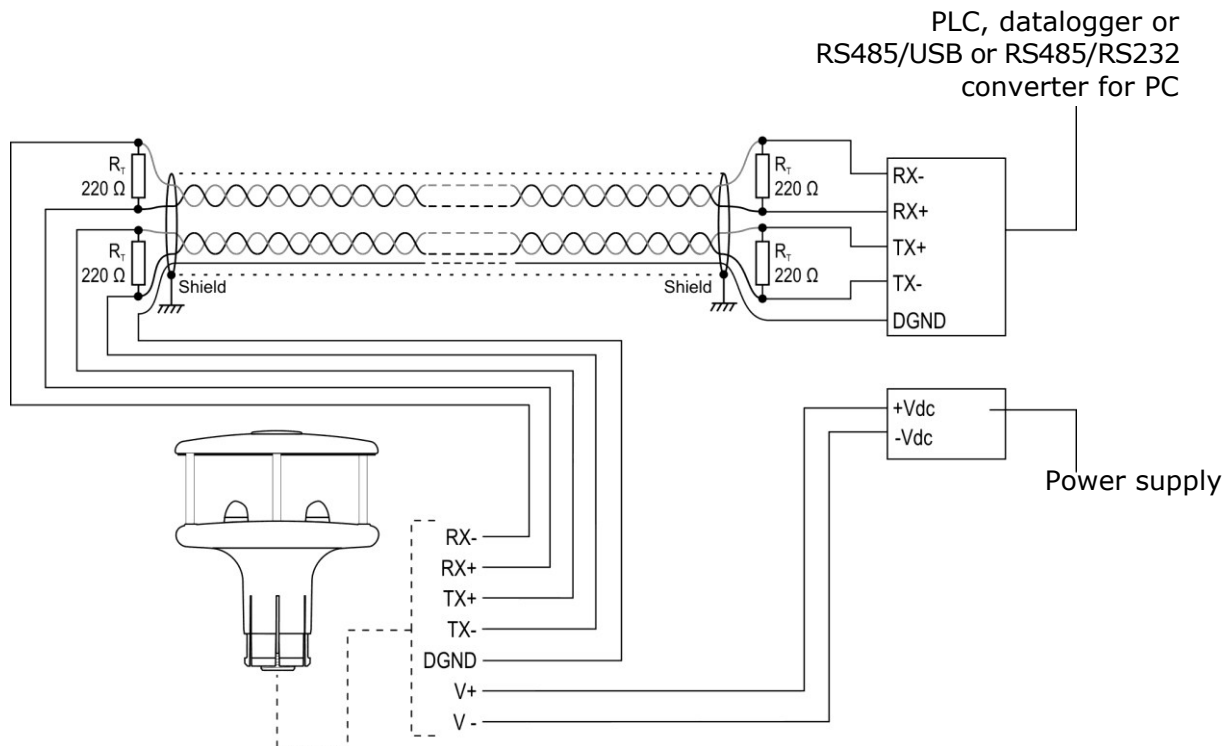

RS422 standard is used for point-to-point connection on long distances, via a shielded cable with two twisted pairs for signals and an additional wire for ground.

The maximum connection length depends on baud rate and cable characteristics. Typically, using a specific RS422 cable, the maximum length is 1200 m.

Before connecting the anemometer to the network, set the address and the communication parameters, if different from the factory preset (see configuration chapter).

5.2.4 SDI-12 connection

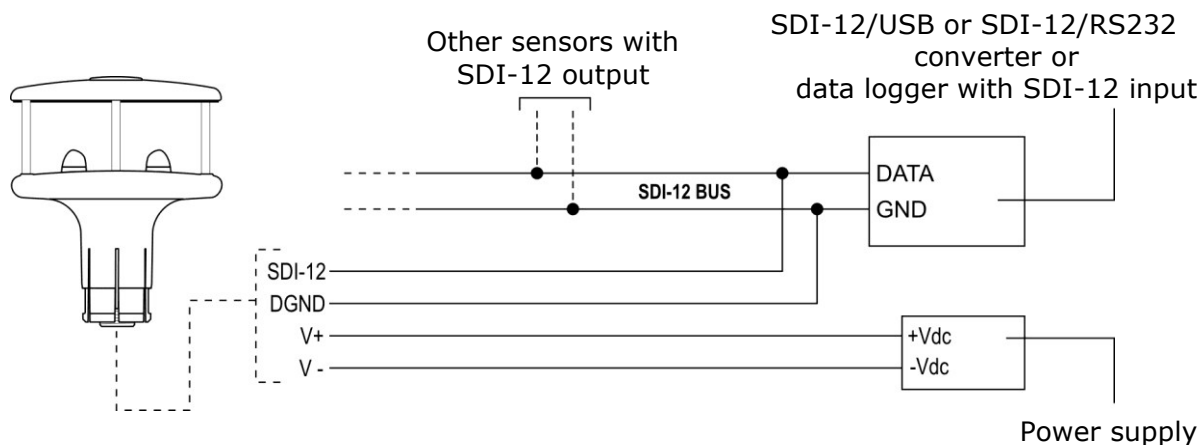

More sensors can be connected in parallel. The baud rate is 1200. The SDI-12 bus maximum length is 60 m.

The instrument should be configured to operate in SDI-12 mode. Set the address (see configuration chapter) before connecting the instrument to the network.

5.2.5 Analog outputs Connection

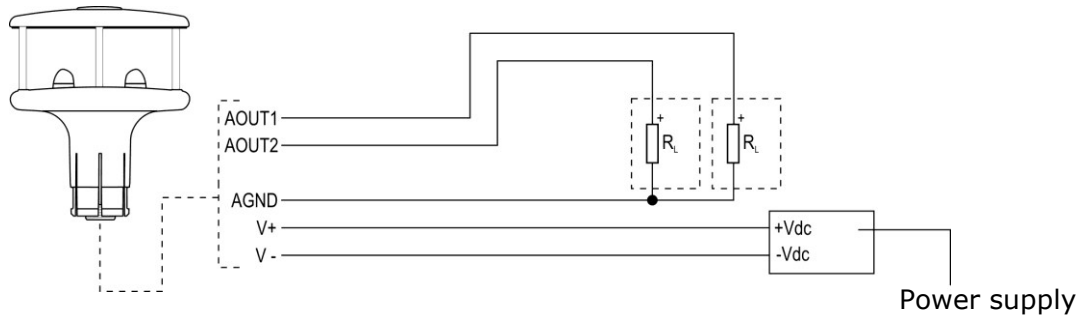

If the cable is used, in which AGND is not available, V- can be used as analog ground (AGND and V- are internally shorted).

The anemometer power supply and the load resistance vary according to the type of analog output:

Analog output	Power supply required	Load resistance
0...20 mA	12...30 Vdc	≤ 300 Ω
4...20 mA	12...30 Vdc	≤ 300 Ω
0...1 V	12...30 Vdc	≥ 10 kΩ
0...5 V	12...30 Vdc	≥ 10 kΩ
0...10 V	15...30 Vdc	≥ 10 kΩ

For associating the outputs with the various available parameters, see configuration chapter.

5.2.6 Heating connection

Models with heating option (**R** option) have an integrated device that heats sonic transducers in order to prevent ice forming and ensure correct operation even in the presence of snow.

The heating power supply (HEAT- e HEAT+) is independent from the instrument main power supply.

Heating needs 10...30 Vdc power supply and 6 W power. Heating is switched on below +4 °C. After switching on, the heating is switched off when the temperature exceeds +8 °C.

5.3 Serial output protocol

Unless otherwise requested, at the first power up the instrument main serial output starts in configuration mode and waits to receive the commands for setting the operating parameters (see configuration chapter) or the connection with the application software.

In this case, in order to activate an operating protocol (NMEA, Modbus-RTU, SDI-12 or ASCII proprietary) it is necessary to set it with the appropriate serial command (CUMn, see configuration chapter) or with the aid of the application software.

If the instrument is set up to work with an operating protocol, the protocol becomes active 10 seconds after power on (in the first 10 seconds the instrument waits for a possible command to enter configuration mode, as explained in configuration chapter).

It is possible to configure the instrument to immediately activate the Modbus-RTU mode upon power up, without waiting 10 seconds (serial commands CGTn).

6 Configuration

Configuration mode allows reading the instrument general info (firmware version, serial number, ...) and setting the instrument operating mode and operating parameters. The configuration of the instrument can be done:

- With the aid of application software (see the software online help), downloadable from the website;
- By sending serial commands (listed in paragraph 6.1) via a standard communication program, setting the following parameters in the program: 115200 (baud rate), 8N2, flow control none;
- Only for some settings, in Modbus-RTU mode via the "Holding Registers".

Accessing configuration mode

The instrument can communicate with the software or a standard serial communication program only if it is in **configuration mode**, factory default, unless otherwise requested.

If the instrument is not set in configuration mode but in one of the available operating modes (NMEA, Modbus-RTU or ASCII proprietary), to enter configuration mode:

- Send **within 10 seconds from power on** (if the instrument is already powered, disconnect and reconnect the power supply) the serial command **@**, if a standard communication program is used, or the request of connection with the software, if the application software is used (see below for the physical interface to use).

Note: if the instrument is in Modbus-RTU operating mode and the possibility to access configuration mode in the first 10 seconds has been disabled (see **CGT** serial command), this procedure cannot be used; in this case see the next point.

- If the instrument is set to immediately activate the Modbus-RTU mode upon power up (see **CGT** serial command), write **208** (decimal value) in the holding register **10000**; this activates the configuration mode for 10 seconds, within which the serial command **@**, if a standard communication program is used, or the request of connection with the software, if the application software is used, must be sent on the current physical interface (e.g. RS485) using the communication parameters 115200 8N2.

Physical interface at power up

During the first 10 seconds from power up, the instrument waits for the serial command **@** or the request of connection with the software on the following physical interface:

- The one set with the **CU0I**^(*) command (or the software: "Instrument settings → Configuration" window), if the instrument is set in configuration or Modbus-RTU mode. The default interface is RS232; the other settable interfaces are RS485 and RS422.
- RS232, if the instrument is set in ASCII proprietary, NMEA or SDI-12 mode.

() The interface set with CU0I is active from power up starting from the instrument firmware revision 2.30. In previous revisions, the interface at power up was always RS232.*

Physical interface in configuration mode

After entering configuration mode, the instrument uses the interface set with the **CU0I** command.

If you enter configuration mode from Modbus-RTU mode (using the holding register 10000), the instrument continues to use the same physical interface used in Modbus-RTU.

6.1 Serial Commands

Instrument information

Command	Reply	Description
G1	&Vnn.nn yyyy/mm/dd	Version and date of firmware
RGD	&yyyy/mm/dd hh.mm.ss	Date and time of calibration
RGS	&nnnnnnnn	Serial number of instrument
RGI	&ccc...ccc	User code
CGIccc...ccc	&	Sets user code to ccc...ccc (max. 34 characters)

Operating Mode:

Command	Reply	Description
CUMn	&	Sets instrument in mode: <ul style="list-style-type: none"> ▪ Configuration if n=0 ▪ RS485 ASCII proprietary if n=1 ▪ RS232 ASCII proprietary if n=2 ▪ SDI-12 if n=3 ▪ NMEA if n=4 ▪ Modbus-RTU if n=5 <i>Default: Configuration (n=0)</i>
RUM	& n	Reads mode set in the instrument

After sending the CUMn command, the instrument remains in configuration mode. Power cycle the instrument to activate the set operating mode.

Physical interface at power up (only for configuration and Modbus-RTU modes):

Command	Reply	Description
CU0In	&	Sets the physical interface used by the instrument at power up: <ul style="list-style-type: none"> ▪ RS232 if n=0 ▪ RS485 if n=1 ▪ RS422 if n=2 <i>Default: RS232 (n=0)</i>
RU0I	& n	Reads the physical interface used by the instrument at power up

The interface set with CU0I is active from power up only if the instrument is set in configuration or Modbus-RTU modes. The physical interface at power up is always RS232 if the instrument is set in other modes.

*The CU0I/RU0I commands are available starting from the instrument firmware revision **2.26**. The interface set with CU0I is active from power up starting from the instrument firmware revision **2.30**. In revisions prior to 2.30, the interface at power up is always RS232.*

Enabling/disabling the wait for the @ command at power up:

Command	Reply	Description
CGTn	&	Enable/disable the 10-second wait for the @ command at power up: <ul style="list-style-type: none"> ▪ Enabled if n=0 ▪ Disabled if n=1 <i>Default:</i> Enabled (n=0)
RGT	& n	Reads the enabling status of the 10-second wait for the @ command at power up

Disabling the 10-second wait for the @ command at power up, and therefore the immediate activation of the set mode, is only possible if the instrument is set in configuration or Modbus-RTU mode; the disabling command has no effect if the instrument is set in other modes, because sending the @ command at power up is the only way to access the configuration (in Modbus-RTU it is instead possible to access the configuration via the holding register 10000).

*The CGT/RGT commands are available starting from the instrument firmware revision **2.30**.*

The immediate activation of the Modbus-RTU mode is useful when the instrument is used in ON/OFF mode to limit consumption (it is powered only for the time necessary to acquire the measurement). With the first 10 seconds disabled, the instantaneous measurements (which do not require averaging) are available **5 seconds after power up**.

Measuring units:

Command	Reply	Description
CGUVn	&	Sets measuring unit of wind speed: <ul style="list-style-type: none"> ▪ m/s if n=1 ▪ cm/s if n=2 ▪ km/h if n=3 ▪ knot if n=4 ▪ mph if n=5 <i>Default:</i> m/s (n=1)
RGUV	n	Reads the wind speed measuring unit set in the instrument
CGUTn	&	Sets temperature measuring unit: <ul style="list-style-type: none"> ▪ °C if n=1 ▪ °F if n=2 <i>Default:</i> °C (n=1)
RGUT	n	Reads the temperature measuring unit set in the instrument
CGUPn	&	Sets pressure measuring unit: <ul style="list-style-type: none"> ▪ mbar if n=1 [Note: 1 mbar=1 hPa] ▪ mmHg if n=2 ▪ inchHg if n=3 ▪ mmH₂O if n=4 ▪ inchH₂O if n=5 ▪ atm if n=6 <i>Default:</i> mbar (n=1)
RGUP	n	Reads the pressure measuring unit set in the instrument

Parameters for NMEA mode:

Command	Reply	Description
CU4Bn	&	Sets Baud Rate for NMEA mode to: <ul style="list-style-type: none"> ▪ 2400 if n=1 ▪ 4800 if n=2 ▪ 9600 if n=3 ▪ 19200 if n=4 ▪ 38400 if n=5 ▪ 57600 if n=6 ▪ 115200 if n=7 <i>Default: 4800 (n=2)</i>
RU4B	& n	Reads Baud Rate setting for NMEA mode
CU4In	&	Sets interface for NMEA mode to: <ul style="list-style-type: none"> ▪ RS232 if n=0 ▪ RS485 if n=1 ▪ RS422 if n=2 <i>Default: RS485 (n=1)</i>
RU4I	& n	Reads interface setting for NMEA mode
CU4Mn	&	Sets parity and stop bits for NMEA mode to: <ul style="list-style-type: none"> ▪ 8N1 if n=0 [No parity, 1 stop bit] ▪ 8N2 if n=1 [No parity, 2 stop bits] ▪ 8E1 if n=2 [Even parity, 1 stop bit] ▪ 8E2 if n=3 [Even parity, 2 stop bits] ▪ 8O1 if n=4 [Odd parity, 1 stop bit] ▪ 8O2 if n=5 [Odd parity, 2 stop bits] The number of data bits is fixed to 8 <i>Default: 8N1 (n=0)</i>
RU4M	& n	Reads current setting of parity and stop bits for NMEA mode
CU4Rnnn	&	Sets transmission interval of string with measurements in NMEA mode to nnn seconds The interval should range within 1 and 255 seconds <i>Default: 1 second</i>
RU4R	& nnn	Reads setting of transmission interval of string with measurements in NMEA mode

Parameters for Modbus-RTU mode:

Command	Reply	Description
CU5Annn	&	Sets Modbus address to nnn The address should range within 1 and 247 <i>Default: 1</i>
RU5A	& nnn	Reads the Modbus address setting
CU5Bn	&	Sets the Baud Rate for Modbus mode to: <ul style="list-style-type: none"> ▪ 9600 if n=3 ▪ 19200 if n=4 ▪ 38400 if n=5 (<i>from firmware vers. 2.21</i>) ▪ 57600 if n=6 (<i>from firmware vers. 2.21</i>) ▪ 115200 if n=7 (<i>from firmware vers. 2.21</i>) <i>Default: 19200 (n=4)</i>
RU5B	& n	Reads Baud Rate setting for Modbus mode
CU5In	&	Sets interface for Modbus mode to: <ul style="list-style-type: none"> ▪ RS232 if n=0 ▪ RS485 if n=1 ▪ RS422 if n=2 <i>Default: RS485 (n=1)</i> Note: with RS232 option you can connect to PC or datalogger 1 instrument only; option useful to do tests without RS232/RS485 conversion.
RU5I	& n	Reads interface setting for Modbus mode
CU5Mn	&	Sets parity and stop bits for Modbus mode to: <ul style="list-style-type: none"> ▪ 8N1 if n=0 [No parity, 1 stop bit] ▪ 8N2 if n=1 [No parity, 2 stop bits] ▪ 8E1 if n=2 [Even parity, 1 stop bit] ▪ 8E2 if n=3 [Even parity, 2 stop bits] ▪ 8O1 if n=4 [Odd parity, 1 stop bit] ▪ 8O2 if n=5 [Odd parity, 2 stop bits] The number of bits is fixed to 8 <i>Default: 8E1 (n=2)</i>
RU5M	& n	Reads the setting of parity and stop bits for Modbus mode
CU5Wn	&	Sets waiting time after transmission in Modbus mode to: <ul style="list-style-type: none"> ▪ Immediate reception if n=0 (violates protocol) ▪ Waiting 3.5 characters if n=1 (respects protocol) <i>Default: Waiting 3.5 characters (n=1)</i>
RU5W	& n	Reads the setting of waiting time after transmission in Modbus mode

Parameters for SDI-12 mode:

Command	Reply	Description
CU3Ac	&	Sets the SDI-12 address to c value The address is an alphanumeric character ranging within 0...9, a...z, A...Z. <i>Default: 0</i>
RU3A	& c	Reads the SDI-12 address set in the instrument

Enabling/disabling the heating:

Command	Reply	Description
CGHn	&	Enables/disables heating: <ul style="list-style-type: none"> ▪ Disables if n=0 ▪ Enables if n=1 <i>Default: Enabled (n=1)</i>
RGH	n	Reads heating enabling state set in the instrument

Measurement parameters:

CWCnnnn	&	Sets wind speed threshold to nnnn value (in hundredths of m/s) Value should range within 0 and 100 hundredths of m/s (= 0...1 m/s) <i>Default: 20 (= 0.2 m/s)</i> (see Note 1)
RWC	& nnnn	Reads the wind speed threshold value set in the instrument (in hundredths of m/s)
CWaLnnn	&	Sets time interval for the calculation of average speed and average direction to nnn value Value should range within 1 and 600 s. If the value is greater than 10 s, it must be an integer multiple of 10. <i>note: the value can be greater than or equal to 10 s starting from firmware version 2.20</i> <i>Default: 1 s</i>
RWaL	& nnn	Reads the time interval for the calculation of average speed and average direction set in the instrument
CWaMn	&	Sets the method for the calculation of average speed and average direction: <ul style="list-style-type: none"> ▪ If n=0: scalar mean. The average intensity is calculated as average of intensities without consideration of direction. The average direction is calculated as average of directions, and expressed according to the extended characteristic (see Note 2). ▪ If n=1: vector mean. The average of the coordinates along each measurement axis is calculated. The average intensity and the average direction are those determined by the two average coordinates. <i>Default: vector mean (n=1)</i>

RWaM	& n	Reads the method for the calculation of the average speed and average direction set in the instrument
CCn <i>note: command available from firmware version 2.06</i>	&	Enables/disables the compass compensation of wind speed and direction: <ul style="list-style-type: none"> ▪ Disables if n=N ▪ Enables if n=Y Default: Enabled (n=Y)

NOTE 1 : WIND SPEED THRESHOLD VALUE

If the wind speed is very low, the determination of the direction can result inaccurate. The instrument allows setting the threshold value of speed below which the direction value is frozen on the last acquired value.

NOTE 2 : WIND DIRECTION EXTENDED CHARACTERISTIC

With 0÷359.9° wind direction measuring range, the analog output continues to oscillate between maximum and minimum scale if the direction continues to slightly fluctuate around 0°:

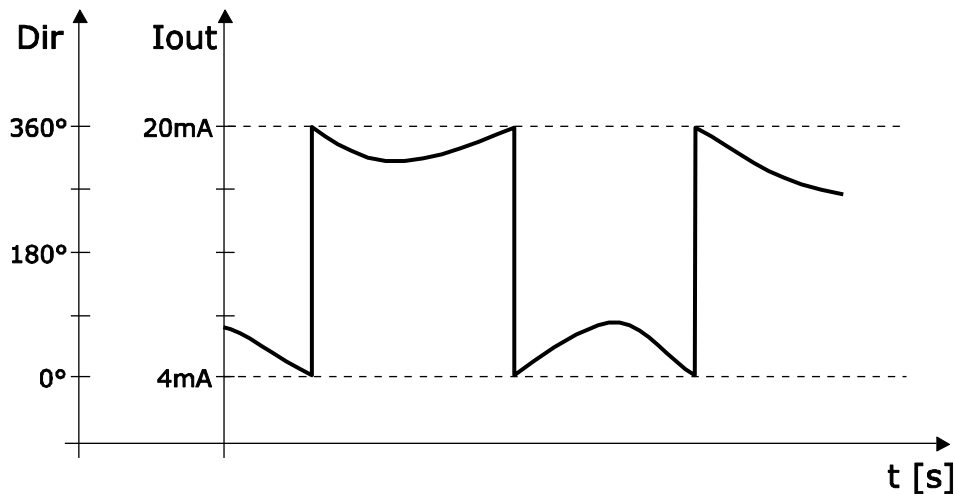

This effect can be reduced through the extended ("wrap-around") characteristic of wind direction. In this mode, the wind direction is considered as corresponding to 0÷539.9° range instead of 0÷359.9°. The wide output fluctuation occurs the first time that the wind direction goes from 0 to 359.9°; if later the "physical" direction goes back to 0°, the analog output will always remain around 360°. Using the extended characteristic, the behavior of the above graph changes into the following:

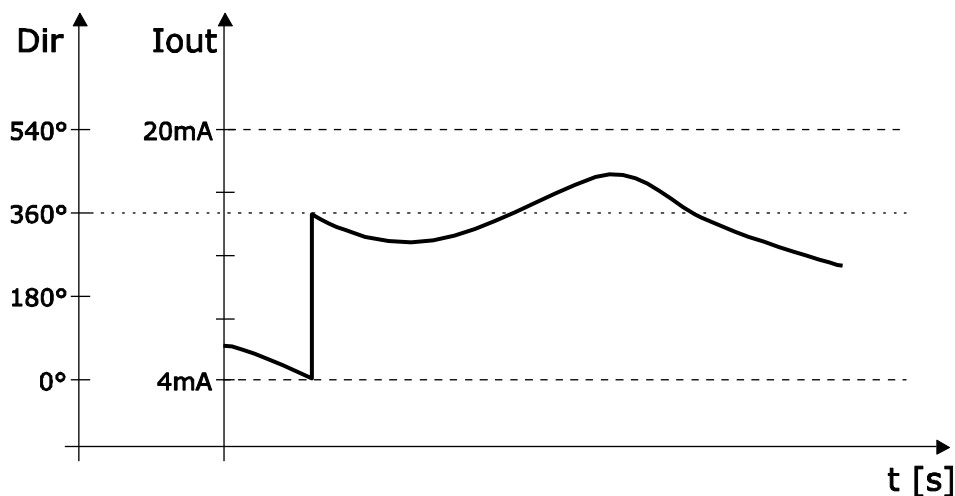

If 539.9° value is exceeded in extended mode, the output goes to the value corresponding to 180°.

The table below shows the correspondence between the value of the analog output and the direction of the wind in the two modes.

Wind direction	4...20mA output		0...1V output		0...5V output		0...10V output	
	standard	extended	standard	extended	standard	extended	standard	extended
0°	4.00	4.00	0.00	0.00	0.00	0.00	0.00	0.00
180°	12.00	9.33	0.50	0.33	2.50	1.67	5.00	3.33
360°	20.00	14.67	1.00	0.67	5.00	3.33	10.00	6.67
540°	--	20.00	--	1.00	--	5.00	--	10.00

Analog outputs:

Command	Reply	Description
CAF1nn	&	Sets offset and direction of the analog outputs to: <ul style="list-style-type: none"> ▪ Standard if nn=00 [ex. 4...20 mA, 0...1 V, 0...5 V, 0...10 V] ▪ Without offset if nn=01 [ex. 0...20 mA] ▪ With offset if nn=02 [ex. 0.2...1 V, 1...5 V, 2...10 V] ▪ Inverted if nn=04 [ex. 20...4 mA, 1...0 V, 5...0 V, 10...0 V] ▪ Inverted without offset if nn=05 [ex. 20...0 mA] ▪ Inverted with offset if nn=06 [ex. 1...0.2 V, 5...1 V, 10...2 V] <i>Default: Standard (nn=00)</i>
RAF1	& nn	Reads offset and direction setting of the analog outputs
CAMn	&	Association of the analog outputs: <ul style="list-style-type: none"> ▪ If n= 0: Output 1 = Mean wind speed Output 2 = Mean wind direction ▪ If n= 1 (see Note 3): Output 1 = Instant wind speed component along V-axis Output 2 = Instant wind speed component along U-axis ▪ If n= 2 (Tunnel mode, see Note 4): Output 1 = Instant wind speed component along the direction indicated by the arrow on the instrument case Output 2 = Instant wind direction referred to the direction indicated by the arrow on the instrument case <i>Default: n=0</i>
RAM	& n	Reads the association of analog outputs

Command	Reply	Description
CAHn	&n	Associates full scale of wind speed analog output to: <ul style="list-style-type: none"> ▪ 5 m/s if n=0 ▪ 10 m/s if n=1 ▪ 15 m/s if n=2 ▪ 20 m/s if n=3 ▪ 25 m/s if n=4 ▪ 30 m/s if n=5 ▪ 35 m/s if n=6 ▪ 40 m/s if n=7 ▪ 45 m/s if n=8 ▪ 50 m/s if n=9 ▪ 55 m/s if n=10 ▪ 60 m/s if n=11 ▪ 65 m/s if n=12 ▪ 70 m/s if n=13 ▪ 75 m/s if n=14 ▪ 80 m/s if n=15 ▪ 85 m/s if n=16 ▪ 90 m/s if n=17 <i>Default: 60 m/s (n=11)</i>
RAH	&n	Reads the value corresponding to the wind speed analog output full scale

NOTA 3: U,V COMPONENTS

By selecting the U and V components, the speed value associated to the initial scale of the two analog outputs is equal to the opposite of the speed value associated to the full scale of the outputs.

For example, if the speed full scale value is set to 60 m/s, the speed range associated to the analog outputs is -60...+60 m/s.

NOTA 4: TUNNEL MODE

In tunnel mode the wind direction measurement is not compensated by the magnetic compass, but the measurement is referred to the direction indicated by the arrow on the instrument case.

The output 2 is set to full scale value if the wind blows in the direction of the arrow, and to initial scale value if the wind blows in the opposite direction.

The initial scale of output 1 is associated to the speed value opposite to that associated to the output full scale.

The arrow on the instrument case should be aligned with the direction of the tunnel.

7 RS232 and RS485 ASCII proprietary modes

In RS232 and RS485 proprietary modes, the instrument automatically sends a string with the detected measurements every second, via RS232 or RS485 depending on the set proprietary mode.

Communication parameters should be set in your PC as follows:

- Baud rate: same as the setting in the instrument (default = 57600, max. speed available)
- Data bits: 8
- Parity: None
- Stop bits: 2

The baud rate of the ASCII proprietary modes can be modified with the software.

The order of the measurements in the string sent by the instrument is as follows:

- Wind speed;
- Wind direction;
- Barometric pressure;
- Temperature, Pt100 sensor;
- Relative humidity;
- Global solar radiation (*only if the measurement option is present*);
- Sonic temperature;
- Compass.

The measurement values consist of 8 justified right characters; spaces are added to the left of the values to obtain the length of 8 characters. The units of measurement are not indicated.

Note: the Wind Gust measurement measurement are not available in RS232 and RS485 ASCII proprietary modes.

*The operation of the proprietary modes described is valid starting from the instrument firmware revision **2.30**.*

8 NMEA mode

NMEA protocol, mainly used in the nautical field and in satellite-based navigation systems, specifies that only one of the devices connected can send data, while the others can only act as recipients.

In NMEA mode, the instrument sends automatically the acquired measurements at regular intervals. The interval is factory-set to 1 second and can be configured within 1 and 255 seconds. To change the interval, you should access the configuration mode and send **CU4Rnnn** command, where nnn indicates the interval value in seconds (see configuration chapter for details regarding the setting of operation parameters).

This mode is available with RS232, RS485 and RS422 serial connections. Communication parameters should be set in the PC or data logger as follows:

- Baud rate: same as the setting in the instrument (default = 4800)
- Data bits: 8
- Parity: same as the setting in the instrument (default = None)
- Stop bits: same as the setting in the instrument (default = 1)

The instrument is compatible with NMEA 0183 V4.00 protocol.

The protocol establishes that data are sent in the following format:

\$<Prefix>,<Data>* <hh><CR><LF>

with <Prefix> = field consisting in 5 alphanumeric characters: the first two indicate the type of transmitting device, the other three indicate the type of transmitted data
 <Data> = values measured by the instrument, separated by commas
 <hh> = checksum, consisting in two hexadecimal characters
 <CR> = character ASCII *Carriage Return*
 <LF> = character ASCII *Line Feed*

The checksum is calculated by performing the exclusive OR of all characters ranging within \$ and * symbols. The 4 most significant bits and the 4 less significant bits of the result are converted in hexadecimal. The hexadecimal value corresponding to the most significant bits is transmitted as the first.

The instrument regularly sends a string in the following general format requested by the protocol:

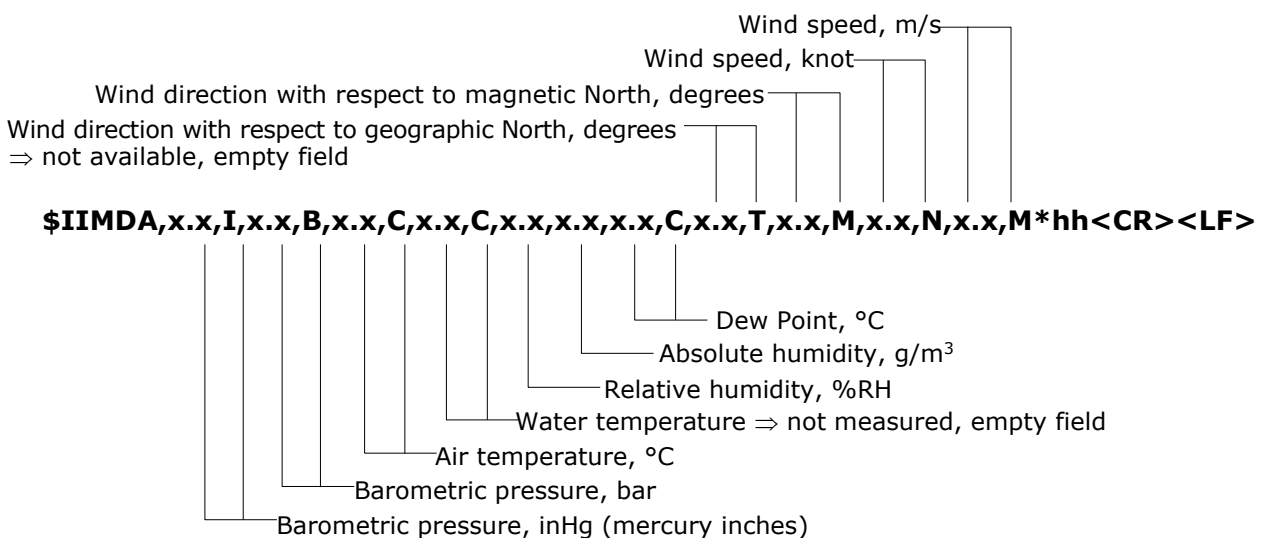

If the instrument model is not equipped to measure some of the quantities indicated in the general format, the relevant fields will be empty and multiple consecutive commas will appear to indicate the missing fields.

The previous string doesn't include the measurement of solar radiation. Models equipped with a pyranometer provide to send the measurement with a second string continuously alternating to the former:

\$IIXDR,a,x.x,a,c--c*hh<CR><LF>

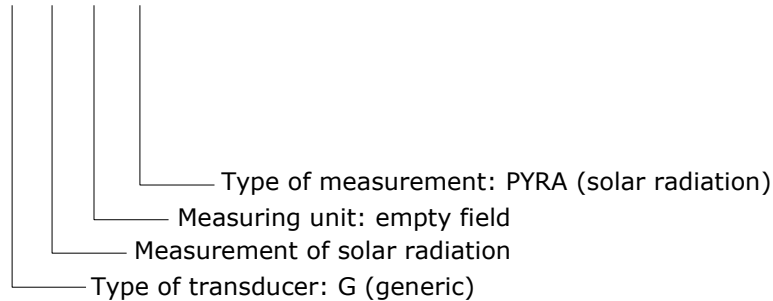

Note: the Wind Gust measurement is not available in NMEA mode.

EXAMPLE

Suppose that there are the following environmental conditions:

- Wind speed = 5.60 m/s (=10.88 knot)
- Wind direction with respect to magnetic North = 38.7°
- Barometric pressure = 1014.9 hPa (= 30.0 inHg)
- Relative humidity = 64.2 %
- Air temperature = 26.8 °C
- Solar radiation = 846 W/m²

Based on the above values, the following can be calculated:

- Absolute humidity = 16.4 g/m³
- Dew Point = 19.5 °C

The strings sent by the instrument in three different cases are indicated below:

- Case 1 – instrument measuring only wind speed and direction:

\$IIMDA,,I,,B,,C,,C,,,,C,,T,38.7,M,10.88,N,5.60,M*3A<CR><LF>

- Case 2 - instrument measuring wind speed and direction, temperature, relative humidity and barometric pressure:

\$IIMDA,30.0,I,1.0149,B,26.8,C,,C,64.2,16.4,19.5,C,,T,38.7,M,10.88,N,5.60,M*36<CR><LF>

- Case 3 - instrument measuring wind speed and direction, solar radiation, temperature, relative humidity and barometric pressure:

\$IIMDA,30.0,I,1.0149,B,26.8,C,,C,64.2,16.4,19.5,C,,T,38.7,M,10.88,N,5.60,M*36<CR><LF>

alternated to:

\$IIXDR,G,846,,PYRA*29<CR><LF>

For additional information regarding the protocol, visit the site "www.nmea.org".

9 Modbus-RTU mode

In Modbus-RTU mode, the instrument sends the acquired measurements only if specifically requested by the PC, PLC or data logger.

The mode is available with RS232, RS485 and RS422 serial connections.

Communication parameters should be set in the PC or data logger as follows:

- Baud rate: same as the setting in the instrument (default = 19200)
- Data bits: 8
- Parity: same as the setting in the instrument (default = Even)
- Stop bits: same as the setting in the instrument (default = 1)

Below is the list of registers.

Input Registers

Address	Description	Format	From FW version	Note
0	Wind speed (x100)	unsigned 16 bits	1.00	(1)
1	Wind direction in degrees (x10)	unsigned 16 bits	1.00	
2	Sonic temperature measured by the first transducers pair (x10)	16 bits	1.00	(1)
3	Sonic temperature measured by the second transducers pair (x10)	16 bits	1.00	(1)
4	Average of the two sonic temperatures measured by the two transducers pairs (x10)	16 bits	1.00	(1)
5	Temperature measured by Pt100 sensor (x10)	16 bits	1.00	(1)
6	Relative humidity in %RH (x10)	unsigned 16 bits	1.00	
7	Barometric pressure (x1000 if the unit of measurement is atm, x10 in the other cases)	unsigned 16 bits	1.00	(1)
8	Compass angle in degrees (x10)	unsigned 16 bits	1.00	
9	Solar radiation in W/m ²	unsigned 16 bits	1.00	
10	Mean wind speed (x100)	unsigned 16 bits	1.00	(1)
11	Mean wind direction in degrees (x10)	unsigned 16 bits	1.00	
12	Absolute humidity in g/m ³ (x100)	unsigned 16 bits	1.00	
13	Dew point temperature (x10)	16 bits	1.00	(1)
14	Wind direction in degrees (x10) with extended feature (see page 21)	unsigned 16 bits	1.00	
15	Wind speed (x100) along V-axis	unsigned 16 bits	2.00	
16	Wind speed (x100) along U-axis	unsigned 16 bits	2.00	

Address	Description	Format	From FW version	Note
17	Status register bit0=1 ⇒ speed measurement error bit1=1 ⇒ compass measurement error bit2=1 ⇒ temperature meas. error bit3=1 ⇒ humidity measurement error bit4=1 ⇒ pressure measurement error bit5=1 ⇒ solar rad. measurement error	unsigned 16 bits	2.00	
18	Wind speed unit of measurement 0 ⇒ m/s 3 ⇒ knot 1 ⇒ cm/s 4 ⇒ mph 2 ⇒ km/h	unsigned 16 bits	2.00	
19	Temperature unit of measurement 0 ⇒ °C 1 ⇒ °F	unsigned 16 bits	2.00	
20	Atm. pressure unit of measurement 0 ⇒ mbar (=hPa) 3 ⇒ mmH ₂ O 1 ⇒ mmHg 4 ⇒ inchH ₂ O 2 ⇒ inchHg 5 ⇒ atm	unsigned 16 bits	2.00	
21	Wind Gust intensity (x100)	unsigned 16 bits	2.20	(1),(2)
22	Wind Gust direction in degrees (x10)	unsigned 16 bits	2.20	(2)

(1) For quantities with configurable measurement unit, the measurement value is expressed in the unit set in the instrument.

(2) The Wind Gust measurement is determined by continuously calculating the wind speed averages in a time interval equal to 3 seconds, and detecting the maximum value of the calculated averages over the time elapsed between the current reading command and the previous reading command (the Wind Gust measurement is reset after each reading command).

Holding Registers

Address	Description	Format	From FW version	Note
5	Wind speed unit of measurement: 1= m/s (default); 2= cm/s; 3= km/h; 4= knot; 5= mph.	unsigned 16 bits	2.26	
6	Time interval, in seconds, for the calculation of average speed and average direction (1..600, default=1). If the value is greater than 10 s, it must be an integer multiple of 10.	unsigned 16 bits	2.26	
7	Waiting time after transmission in Modbus mode: 0= Immediate reception (violates protocol); 1= Waiting 3.5 characters (respects protocol, default).	unsigned 16 bits	2.26	

Address	Description	Format	From FW version	Note
8	MODBUS parity and stop bits: 0=8N1; 1=8N2; 2=8E1 (default); 3=8E2; 4=8O1; 5=8O2. [N=no parity, E=even parity, O=odd parity] <i>Note: the change takes effect the next time the instrument is switched on.</i>	unsigned 16 bits	2.26	
9	Modbus Baud Rate: 3=9600; 4=19200 (default); 5=38400; 6=57600; 7=115200. <i>Note: the change takes effect the next time the instrument is switched on.</i>	unsigned 16 bits	2.26	
10	Modbus address (1...247, default=1).	unsigned 16 bits	2.26	
11	Enables/disables the compass compensation of wind speed and direction: 0= Disabled; 1= Enabled (default).	unsigned 16 bits	2.26	
10000	Enables the configuration mode. By writing 0x00D0 (=208) in this register, the instrument enables the configuration mode for 10 seconds, maintaining the physical interface used for the Modbus protocol, with communication parameters 115200 8N2. During the 10 seconds it is possible to send the @ command to keep the instrument in configuration mode (in this case, at the end of the configuration it is necessary to power cycle the instrument to return to Modbus mode). The register value is automatically reset when returning to Modbus mode.	unsigned 16 bits	2.30	

Address	Description	Format	From FW version	Note
30001	<p>Starts the instrument firmware update.</p> <p>By writing 0x69A5 (=27045) in this register, the instrument suspends the Modbus protocol and waits to receive the firmware update file, via XModem or software, on the serial interface set for configuration mode (see software: "Instrument settings → Configuration" window).</p> <p>The Modbus protocol is automatically reactivated after 10 s from the conclusion of the update.</p>	unsigned 16 bits	2.26	

The configuration changes made through the holding registers have immediate effect, except for those relating to registers 8 and 9, which take effect the next time the instrument is switched on.

INSTRUMENT ERROR CONDITIONS (function **07h**)

The Modbus function code 07h allows reading the 8-bit register containing information about error conditions of the instrument.

Each register bit corresponds to an error condition:

- *Bit 0*: Wind speed measurement error;
- *Bit 1*: Compass measurement error;
- *Bit 2*: Temperature measurement error;
- *Bit 3*: Relative humidity measurement error;
- *Bit 4*: Barometric pressure measurement error;
- *Bit 5*: Solar radiation measurement error;
- *Bit 6*: Not assigned;
- *Bit 7*: Not assigned.

There is an error condition if the corresponding bit value is 1.

Note: the register does not include the precipitation measurement error.

READING OF INSTRUMENT GENERAL INFORMATION (function **2Bh / 0Eh**)

The Modbus function code 2Bh / 0Eh allows reading the basic general information of the instrument, consisting of:

- Manufacturer;
- Instrument model;
- Firmware version.

For additional information regarding the protocol, visit the site "www.modbus.org".

10 SDI-12 mode

In SDI-12 mode, the instrument sends the acquired measurements only if specifically requested by the PC.

To use this mode, an SDI-12 serial connection should be performed. The communication parameters of the protocol are:

- Baud rate: 1200
- Data bits: 7
- Parity: Even
- Stop bit: 1

Communication with the instrument is performed by sending a command in the following format:

<Address><Command>!

with <Address> = address of the instrument the command is sent to.
<Command> = type of operation requested to the instrument.

The instrument reply is as follows:

<Address><Data><CR><LF>

with <Address> = address of the replying instrument
<Data> = information sent by the instrument
<CR> = ASCII character *Carriage Return*
<LF> = ASCII character *Line Feed*

The instrument is compatible with V1.3 version of the protocol.

The table below shows the available SDI-12 commands. To comply with the SDI-12 standard, the instrument address is indicated in the table with the letter **a**. The instrument comes with a factory address preset to 0. The address can be modified by using the proper SDI-12 command reported in the table.

SDI-12 COMMANDS

Command	Reply	Description
a!	a<CR><LF>	Checks for the presence of the instrument.
aI!	allccccccmmmmmmvvx...x<CR><LF> where: a = address of the instrument (1 character) II = compatible SDI-12 version (2 characters) ccccccc = manufacturer (8 characters) mmmmm = instrument model (6 characters) vvv = firmware version (3 characters) x...x = instrument version (up to 13 characters)	Request for instrument information.
aAb! where: b = new address	b<CR><LF> Note: if character b is not an acceptable address, the instrument answers with a in the place of b.	Change of instrument address.
?!	a<CR><LF>	Request for instrument address. If more than a sensor is connected to the bus, a conflict will occur.

Type M (start measurement) commands

Command	Reply	Description
Wind speed and direction, temperature, relative and absolute humidity, dew point, barometric pressure, solar radiation and compass angle		
aM!	attn<CR><LF> where: a = address of the instrument (1 character) ttt = number of seconds needed by the instrument to make measurements available (3 characters) n = number of detected quantities (1 character) Note: ttt = 000 means data immediately available.	Request to detect the measurements.
aD0! aD1! aD2!	a<WS><WD><T><CR><LF> a<RH><AH><DP><CR><LF> a<P><R><C><CR><LF> where: a = address of the instrument <WS> = wind speed <WD> = wind direction in degrees <T> = temperature (sensor Pt100) <RH> = relative humidity in %RH <AH> = absolute humidity in g/m ³ <DP> = dew point temperature <P> = barometric pressure <R> = solar radiation in W/m ² <C> = compass angle in degrees	Request for measured values.
Average wind speed and direction and wind gust		
aM1!	attn<CR><LF> where: a = address of the instrument (1 character) ttt = number of seconds needed by the instrument to make measurements available (3 characters) n = number of detected quantities (1 character) Note: ttt = 000 means data immediately available.	Request to detect the measurements.
aD0! aD1! aD2!	a<WSa><WDa><CR><LF> a<WGS><WGD><CR><LF> a<TBT><TBL><RR><CR><LF> where: a = address of the instrument <WSa> = mean wind speed <WDa> = mean wind direction in degrees <WGS> = wind Gust intensity ^(note 5) <WGD> = wind Gust direction in degrees ^(note 5)	Request for measured values.

Type R (continuous measurements) commands

Command	Reply	Description
aR0!	a<WS><WD><T><CR><LF>	Request for measured values.
aR1!	a<RH><AH><DP><CR><LF>	
aR2!	a<P><R><C><CR><LF>	
aR3!	a<WSa><WDa><CR><LF>	
aR4!	a<WGS><WGD><CR><LF>	
aR5!	a<TBT><TBL><RR><CR><LF>	
	where: a = address of the instrument <WS> = wind speed <WD> = wind direction in degrees <T> = temperature (sensor Pt100) <RH> = relative humidity in %RH <AH> = absolute humidity in g/m ³ <DP> = dew point temperature <P> = barometric pressure <R> = solar radiation in W/m ² <C> = compass angle in degrees <WSa> = mean wind speed <WDa> = mean wind direction in degrees <WGS> = wind Gust intensity ^(note 5) <WGD> = wind Gust direction in degrees ^(note 5)	

Notes:

- 1) The positive values are always preceded by a + sign to identify the beginning of the measurement value.
- 2) The values of the quantities with configurable unit of measurement (wind speed, temperature and barometric pressure) are expressed in the unit set in the instrument. <DP> measurement is in the same unit as temperature.
- 3) If a quantity measurement is in error condition, a negative value consisting in a series of 9 is sent.
- 4) The fields corresponding to quantities not measured by that particular model are always present: a negative value consisting in a series of 9 is sent.
- 5) The Wind Gust measurement is available starting from firmware version **2.20**. The Wind Gust measurement is determined by continuously calculating the wind speed averages in a time interval equal to 3 seconds, and detecting the maximum value of the calculated averages over the time elapsed between the current reading command and the previous reading command (the Wind Gust measurement is reset after each reading command).

For additional information regarding the protocol, visit the site "[www. sdi-12.org](http://www.sdi-12.org)".

11 Maintenance

Wind speed sensors does not generally require maintenance.

In case abnormal measures are detected, verify the cleanliness of the ultrasonic sensors. For cleaning, use a moistened soft cloth. The sensors should be wiped gently: **do not brush or twist the sensors.**

12 Instrument storage

Instrument storage conditions:

- Temperature: -40...+80 °C.
- Humidity: less than 90 %RH no condensation.
- In storing, avoid locations where:
 - There is a high humidity level.
 - The instrument is exposed to direct sunlight.
 - The instrument is exposed to a high temperature source.
 - There are high vibration levels.
 - There is presence of vapor, salt and/or corrosive gas.

13 Safety instructions

The instrument proper operation and operating safety can be ensured only in the climatic conditions specified in this manual and if all standard safety measures as well as the specific measures described in this manual are followed.

Do not use the instrument in places where there are:

- Corrosive or flammable gases.
- Direct vibrations or shocks to the instrument.
- High-intensity electromagnetic fields, static electricity.

User obligations

The instrument operator shall follow the directives and regulations below that refer to the treatment of dangerous materials:

- EU directives on workplace safety.
- National law regulations on workplace safety.
- Accident prevention regulations.

14 Useful information

WARRANTY

The manufacturer is required to respond to the "factory warranty" only in those cases provided by Legislative Decree 6 September 2005 - n. 206. Each instrument is sold after rigorous inspections; if any manufacturing defect is found, it is necessary to contact the distributor where the instrument was purchased from. During the warranty period (24 months from the date of invoice) any manufacturing defects found will be repaired free of charge. Misuse, wear, neglect, lack or inefficient maintenance as well as theft and damage during transport are excluded. Warranty does not apply if changes, tampering or unauthorized repairs are made on the product. Solutions, probes, electrodes and microphones are not guaranteed as the improper use, even for a few minutes, may cause irreparable damages.

The manufacturer repairs the products that show defects of construction in accordance with the terms and conditions of warranty included in the manual of the product. For any dispute, the competent court is the Court of Padua. The Italian law and the "Convention on Contracts for the International Sales of Goods" apply.

TECHNICAL INFORMATION

The quality level of our instruments is the result of the continuous product development. This may lead to differences between the information reported in the manual and the instrument you have purchased.

We reserve the right to change technical specifications and dimensions to fit the product requirements without prior notice.

DISPOSAL INFORMATION

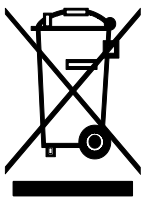

Electrical and electronic equipment marked with specific symbol in compliance with 2012/19/EU Directive must be disposed of separately from household waste. European users can hand them over to the dealer or to the manufacturer when purchasing a new electrical and electronic equipment, or to a WEEE collection point designated by local authorities. Illegal disposal is punished by law.

Disposing of electrical and electronic equipment separately from normal waste helps to preserve natural resources and allows materials to be recycled in an environmentally friendly way without risks to human health.



