

**e018a DA18K**  
**e018b DA18KE**  
 Data acquisition systems



SIAP+MICROS

## Index

1	Safety precautions and measures .....	4
1.1	Intended use .....	4
1.2	Warnings.....	4
1.3	Handling.....	5
1.4	Unpacking.....	5
1.5	Procedure for switching on the control unit .....	5
1.6	During operation .....	6
1.7	Storage .....	6
1.8	Maintenance .....	6
1.8.1	Cleaning the device .....	6
1.8.2	Electrical protections .....	6
2	Hardware and connections.....	7
2.1	Housing of processing and storage electronics.....	7
2.2	Housing of data acquisition power supply management electronics.....	9
2.3	Power supplies .....	11
2.4	PT100 inputs.....	12
2.5	Analogue inputs .....	13
2.5.1	Analogue inputs on 6-pin connector .....	13
2.5.2	Analogue inputs on 3-pin connector .....	13
2.5.3	Analogue inputs on 4-pin connector .....	14
2.5.4	Analogue inputs configurable in 4 – 20 mA .....	14
2.6	Digital inputs .....	14
2.7	Digital outputs .....	16
2.8	Connectivity .....	16
2.8.1	RS-232 serial interfaces with criteria: COM1, COM4, COM8 .....	16
2.8.2	RS-485 serial interfaces: COM2, COM6, COM7 .....	17
2.8.3	RS-232 and RS-485 hybrid serial interfaces: COM3.....	17
2.8.4	SDI-12 interfaces: COM5, COM9 .....	18
2.8.5	Network interface .....	18
2.8.6	USB host interfaces .....	18
2.8.7	USB slave interfaces.....	18
2.9	External storage unit and display .....	19
3	Use and programming guide .....	20
3.1	Operating system.....	20
3.1.1	Network connections.....	21
3.1.2	Saving settings.....	22
3.2	Programme start.....	23

3.3	Clock settings .....	23
3.4	Display pages .....	24
3.4.1	Measures .....	24
3.4.2	Data.....	25
3.4.3	Parameters.....	26
3.4.4	Status .....	26
3.4.5	Settings .....	27
3.4.6	Log .....	28
3.5	Description of functions .....	28
3.5.1	Initialisation and configuration file .....	28
3.5.2	Main cycle and secondary processes .....	31
3.5.3	User parameters .....	32
3.5.4	Acquisition functions .....	32
3.5.5	Processing functions .....	34
3.5.6	Control functions .....	39
3.5.7	Data storage.....	41
3.5.8	Data backup .....	43
3.5.9	Transmission functions .....	43
3.5.10	Display .....	46
3.5.11	Basic code.....	46
3.5.12	Variables and operators.....	46
3.6	Data record report.....	47
3.7	Command interpretations .....	48
3.7.1	Reception protocols .....	48
3.7.2	General commands.....	49
3.7.3	Variable management.....	49
3.7.4	Data archive management.....	50
3.7.5	Output commands.....	53
3.7.6	MODBUS protocol specification.....	54
4	Regulations .....	56
4.1	Safety regulations .....	56
4.2	EMC .....	56
5	Environmental conditions of use.....	57
6	Revision history .....	58
7	Declaration of Conformity .....	59
Appendix A: Quick guide.....		60
A.1	Setting the clock from the display .....	60
A.2	Changing the configuration file from USB.....	62
A.3	Procedure for replacing the datalogger programme .....	66

## 1 Safety precautions and measures

---

DA18K is a measuring instrument that enables the acquisition, processing and storing of electrical quantities. It is composed of two modules, one for the processing and storing of data and the other for the acquisition of physical data and management of the power supply of the entire system. This equipment complies with the requirements of the Low Voltage Directive (LVD) 2014/35/EU and the Electromagnetic Compatibility (EMC) Directive 2014/30/EU. For the safety of the operator it is necessary to follow the procedures described in this manual and carefully read all the notes.

DA18K is an instrument designed to be used by trained personnel. The manufacturer declines all responsibility for faults due to non-observance of instructions, tampering, uses not provided for in this manual, misuse of the equipment, or use by untrained operators. Only authorised personnel should have access to the work area for normal use and maintenance operations.

- The device must not be operated in the presence of flammable gases, fumes or in any environment at risk of explosion.
- Do not carry out any measure if anomalies are found in the device, such as deformations or breakages.
- Do not remove, replace or modify any electrical or mechanical part without permission.
- Replacement of components and internal work must only be carried out by qualified and trained maintenance personnel, after disconnecting the main electricity supply.
- Pay attention to all warning labels against potentially hazardous procedures.

### 1.1 Intended use

---

The DA18K series control unit is local management system for environmental and weather/climate monitoring stations and can be directly interfaced with weather sensors, analysers, chemical-physical probes, actuators, etc. It has been designed to meet the most varied needs of data acquisition, processing and transmission, from the simplest for individual stations to the most complex for networks of various types of stations managed by remote control centres. The chosen manufacturing criteria and in particular the open and modular structure of the DA18K control unit allow considerable application possibilities both in terms of simplicity of use and configurability, and in terms of future versatility and expandability. Keep this manual carefully and always keep a copy available for operators at all times.

### 1.2 Warnings

---

The manufacturer declines all responsibility for faults due to non-observance of instructions, tampering, uses not provided for in this manual, misuse of the equipment, or use by untrained operators. Only authorised personnel should have access to the work area for normal use and maintenance operations.

#### General safety regulations

- The device must be connected to an earth (or safety) system.
- The device must not be operated in the presence of flammable gases, fumes or in any environment at risk of explosion.
- Do not remove, replace or modify any electrical or mechanical part without permission.
- Replacement of components and internal work must only be carried out by qualified and trained maintenance personnel, after disconnecting the main electricity supply.
- Pay attention to all warning labels against potentially hazardous procedures.

## **1.3 Handling**

---

To avoid damage to the equipment, always keep it in an upright position without agitating during transportation.

## **1.4 Unpacking**

---

Before removing the packaging and installing the device, make sure the following precautions have been taken:

- Use suitable gloves to protect against any abrasions, etc.
- Return the device to the supplier if any damage charged to the supplier occurs during transport.
- Once removed from the packaging, place the device and its components on a flat surface.
- Always avoid turning the device upside down to safeguard the display.
- Pay attention to the connectors on the front and side of the device case during operation.

Before installing the device, check that:

- The mains voltage in the installation area complies with the operating conditions of the device.
- Check that the main switch of the device is deactivated.

Carefully follow the installation and start-up instructions in this manual before turning the device on.

## **1.5 Procedure for switching on the control unit**

---

The following procedure allows the proper power supply of the DA18K control unit with an external power supply or back-up battery.

1. Connect the battery to the power supply connector to the BATT – GND pins (see section 2).
2. Pay attention to the polarity of the battery: BATT must be connected to the positive terminal and GND to the negative terminal<sup>1</sup>.
3. Connect the external 12V power supply to the VCC and GND pins of the power supply connector (see section 2). This operation must be performed with the power supply turned off.
4. Pay attention to the polarity: VCC must be connected to the positive terminal and GND to the negative terminal.
5. Turn on the DA18K in battery mode with the external power supply switched off.
6. Turn on the external power supply.

---

<sup>1</sup> The DA18K is equipped with reverse polarity protection devices. In any case, pay attention to the connections.

## **1.6 During operation**

---

During operation, do not interfere with the electrical connections for analogue and digital inputs and power supply connections.

## **1.7 Storage**

---

If you do not plan to use the device for an extended period of time (at least one year), disconnect all cables from the device, place it in a transparent plastic bag along with a desiccant sachet and seal the bag with adhesive tape. Label the bag with the contents and weight of the device, inserting the words "HANDLE WITH CARE".

Store the device in an environment with a temperature between 0 and 60 degrees with humidity not exceeding 80%. Ensure that the device is stored in a stable position and that it cannot be damaged or moved by carelessness or distraction. Do not overlay other instruments or weights. Do not put the device on other instruments and in any case make sure that the underlying support is solid and stable.

## **1.8 Maintenance**

---

### **1.8.1 Cleaning the device**

---

Disconnect all connection cables before cleaning the device. Use a soft and dry cloth for cleaning. Never use damp cloths, solvents, water or other liquids.

### **1.8.2 Electrical protections**

---

The product is equipped with electrostatic protection devices on every channel and peripheral device. The power supplies are also equipped with circuitry against reverse polarity and self-resettable fuses for overcurrent protection. See section 2 for more details.

## 2 Hardware and connections

### 2.1 Housing of processing and storage electronics

**Assembly and dimensions**

**DA18K datalogger terminal block layout**

ix	COM8	SDI-12	COM7	COM3
GND	RX TX RTS CTS	GND D2 D1 +12	B A	RX-B GND TX-A
10	11 12 13	O0 O1 O2 O3	WD	B GND A + -
				4 INPUT / 4 OUTPUT COM2 +12Vdc

PINOUT COM1 / COM6		
1	5	2 - RX
6	9	3 - TX
		5 - GND
		7 - RTS
		8 - CTS
		1 - A - RS485
		9 - B - RS485

PINOUT COM4		
1	5	1 - DCD
2	6	2 - RX
3	7	3 - TX
4	8	4 - DTR
5	9	5 - GND
		6 - DSR
		7 - RTS
		8 - CTS
		9 - RI

The housing of data processing and storage electronics includes:

- One Type B USB port for connection via USB cable to a PC or terminal, with which it is possible to access the datalogger's internal folders.
- One Type A USB port for peripheral connections such as keyboard, mouse, pen drive. Although the connector has two ports, only the upper port can be used to connect peripheral devices. Do not connect anything to the lower port.
- One UTP port for connection to a local network via Ethernet protocol.
- Two 9-pin male D-SUB connectors for connecting serial devices such as modems, PCs, sensors and other devices with RS-232 or RS-485 interface:
  - **COM1**: RS-232 to pins 2, 3, 5, 7 and 8 of the D-SUB port as shown in the above figure.

- **COM4:** R-232 complete with all criteria.
- **COM6:** RS-485 to pins 1 and 9 of the D-SUB port as shown in the above figure.
- A 28-pin multi-function connector for the connection of:
  - Possible power supply<sup>2</sup>: two pins for 12V DC power supply input.
  - **COM2:** three pins for an RS-485 serial port for the connection of serial devices such as modems, PCs, sensors and other equipment with RS-485 interface.
  - **COM3:** three pins for an RS-485 serial port for the connection of serial devices such as modems, PCs, sensors and other equipment with RS-485 interface. The COM3 port can be transformed into an additional RS-232 port.
  - **SDI-12:** four pins for two independent SDI-12 ports for the connection of peripheral devices with SDI-12 protocol. The port consists of a 12V power supply, two D1 and D2 data lines, ground. D1 and D2 are seen as two SDI-12 serial ports, **COM5** and **COM9** respectively.
  - **COM7:** two pins for an RS-485 serial port for the connection of serial devices such as modems, PCs, sensors and other equipment with RS-485 interface.
  - **COM8:** four pins for an RS-232 serial port with RTS/CTS flow control for the connection of serial devices such as modems, PCs, sensors and other equipment with RS-232 interface.
  - **Watchdog:** a watchdog signal to the outside
  - **Digital outputs:** four open collector digital outputs
  - **Digital inputs:** four opto-isolated digital inputs
  - **Isolated ground:** an isolated ground for digital inputs
- An SD (Secure Digital) slot for the insertion of an industrial grade SD card used by the programme for the backup of stored data.
- A switch for backlighting the display (forces switch-off of the display backlight).
- A button for forced exit from the datalogger suspend status.
- Ten LEDs representing, respectively:
  - ON, green LED indicating power on status
  - STS, green LED which flashes if the datalogger programme (DA9000.exe) is in cycle
  - D1, green LED indicating a transmit/receive on SDI-12 COM5
  - D2, green LED indicating a transmit/receive on the SDI-12 COM9
  - TX, blue LED, and RX, red LED of COM2, indicating the status of the transmit and receive lines of serial port 2

---

<sup>2</sup> Only if the power supply does not come from the BASE18K.

- TX, blue LED, and RX, red LED of COM3, indicating the status of the transmit and receive lines of serial port 3
- TX, blue LED, and RX, red LED of COM7, indicating the status of the transmit and receive lines of serial port 7

## 2.2 Housing of data acquisition power supply management electronics

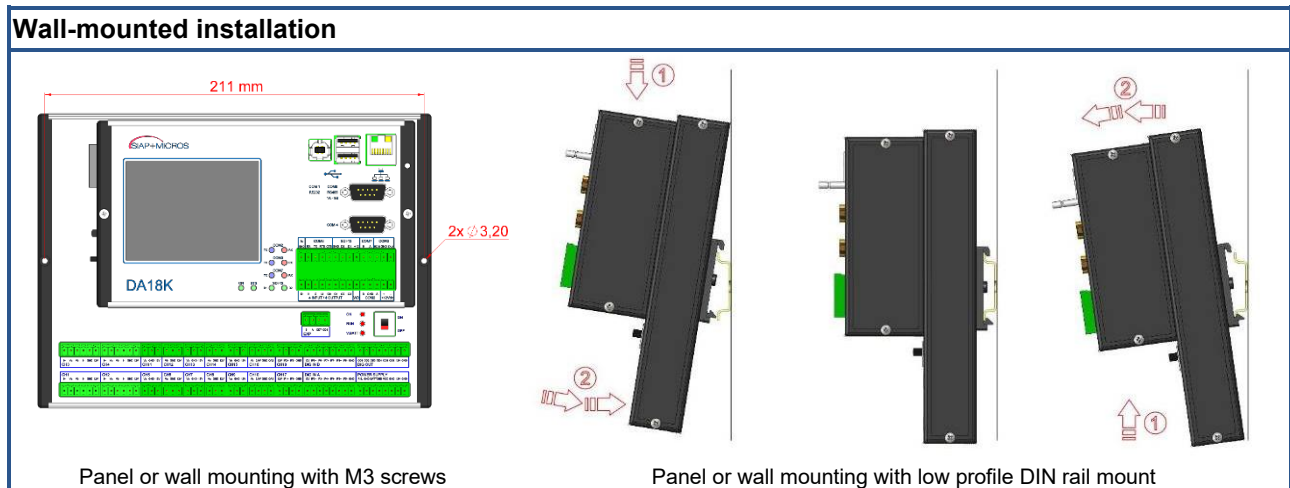
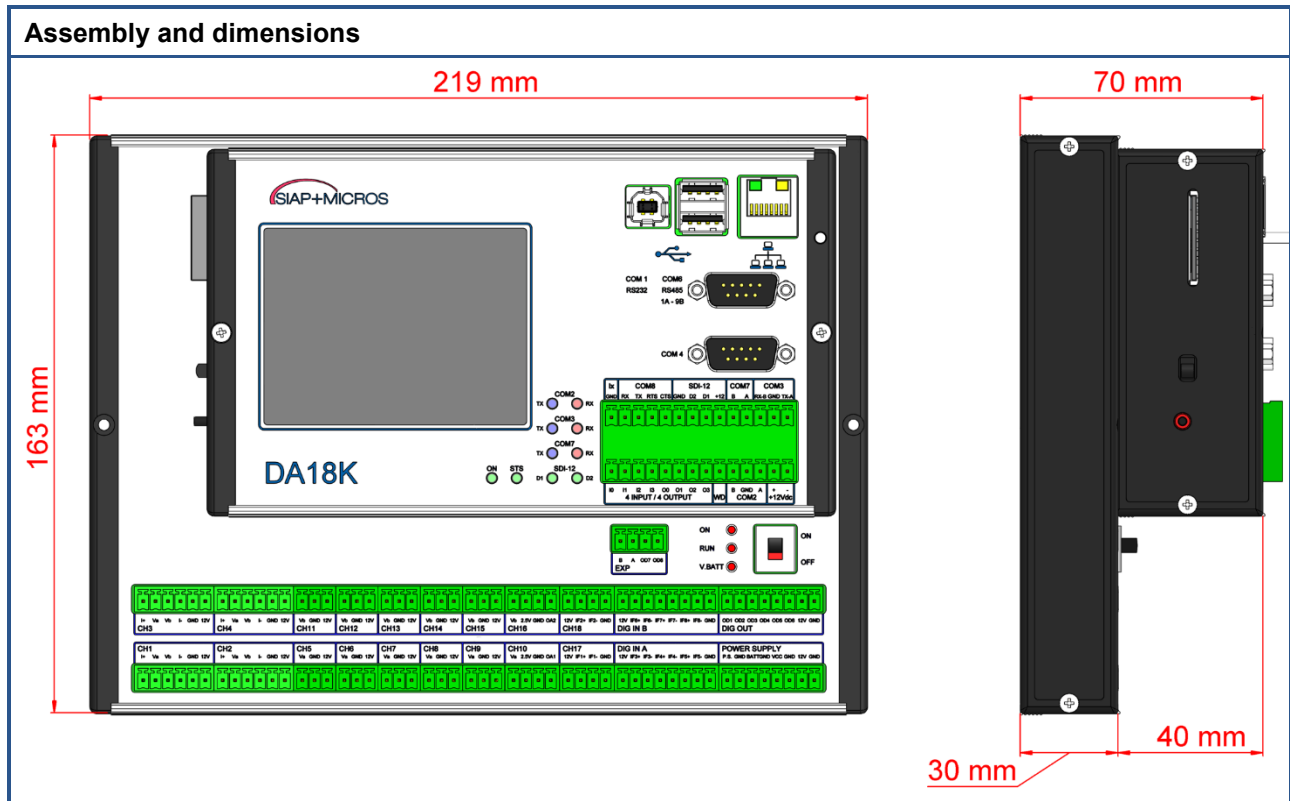

The DA18K is available in two versions that differ by the number of analogue and digital inputs in the acquisition card: DA18K, a basic version, and DA18KE, an expanded version. Here we will briefly describe the terminal blocks, with a more detailed description of each section in the following paragraphs.

### Connections in DA18K terminal block

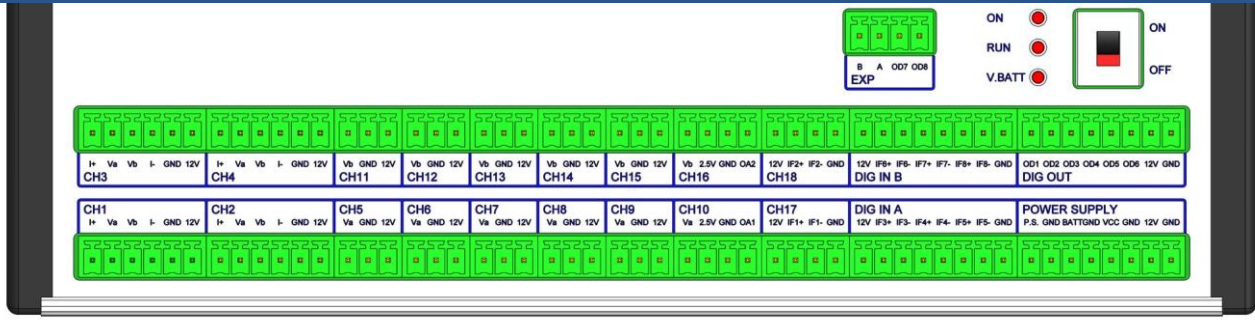

<b>CH1 ÷ CH4: Analogue inputs (24-bit)</b> <ul style="list-style-type: none"> <li>• One differential input (<math>V_a - V_b</math>)</li> <li>• Two inputs referred to ground (<math>V_a - GND</math>, <math>V_b - GND</math>)</li> <li>• One PT100 input (<math>I+ - V_a - V_b - I-</math>)</li> <li>• <math>V_{ALM}</math> sensor power supply</li> </ul>	<b>CH5÷CH9, CH11÷CH15: Analogue inputs (24-bit)</b> <ul style="list-style-type: none"> <li>• One differential input on each pair of connectors (<math>V_a - V_b</math>) (CH5/CH11, CH6/CH12, CH7/CH13, CH8/CH14, CH9/CH15)</li> <li>• One input referred to ground on a single connector (<math>V_a - GND</math>, <math>V_b - GND</math>)</li> <li>• <math>V_{ALM}</math> sensor power supply</li> </ul>
<b>CH10, CH16: Analogue inputs (24-bit), analogue outputs (12-bit)</b> <ul style="list-style-type: none"> <li>• One differential input on each pair of connectors (<math>V_a - V_b</math>) (CH10/CH16)</li> <li>• One input referred to ground on a single connector (<math>V_a - GND</math>, <math>V_b - GND</math>)</li> <li>• Precision reference voltage 2.5V – 25mA (e.g.: potentiometer wind direction sensor)</li> <li>• Analogue output 0 – 2V, 12-bit</li> </ul>	<b>CH17, CH18: Opto-isolated digital inputs</b> <ul style="list-style-type: none"> <li>• Frequency</li> <li>• Counter</li> <li>• Logic state</li> <li>• <math>V_{ALM}</math> sensor power supply</li> </ul>
<b>DIG IN A, DIG IN B: Opto-isolated digital input</b> <ul style="list-style-type: none"> <li>• Frequency</li> <li>• Counter</li> <li>• Logic state</li> <li>• <math>V_{ALM}</math> sensor power supply</li> </ul>	<b>DIG OUT: Open drain digital outputs and power outputs</b> <ul style="list-style-type: none"> <li>• Open drain digital outputs</li> <li>• <math>V_{SWT}</math> switch-off power output</li> </ul>
<b>EXP : RS485 and open drain digital outputs</b> <ul style="list-style-type: none"> <li>• RS485</li> <li>• Open drain digital outputs</li> </ul>	<b>POWER SUPPLY : Power supplies</b> <ul style="list-style-type: none"> <li>• Solar panel input (SP – GND)</li> <li>• Battery input (BATT – GND)</li> <li>• External power input (VCC – GND)</li> <li>• <math>V_{PWR}</math> power output (12V – GND)</li> </ul>

### Additional terminal block connections (only for DA18KE)

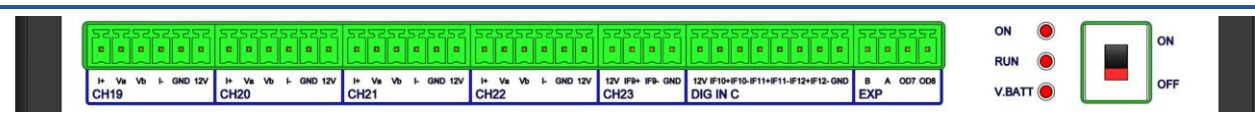

<b>CH19 ÷ CH22 : Analogue inputs (24-bit)</b> <ul style="list-style-type: none"> <li>• One differential input (<math>V_a - V_b</math>)</li> <li>• Two inputs referred to ground (<math>V_a - GND</math>, <math>V_b - GND</math>)</li> <li>• One PT100 input (<math>I+ - V_a - V_b - I-</math>)</li> <li>• <math>V_{ALM}</math> sensor power supply</li> </ul>	<b>CH23 : Opto-isolated digital inputs</b> <ul style="list-style-type: none"> <li>• Frequency</li> <li>• Counter</li> <li>• Logic state</li> <li>• <math>V_{ALM}</math> sensor power supply</li> </ul>
<b>DIG IN B : Opto-isolated digital inputs</b> (see figure in “Additional terminal block connections”) <ul style="list-style-type: none"> <li>• Sinusoidal input (IF7 – IF8)</li> </ul>	<b>DIG IN C : Opto-isolated digital inputs</b> <ul style="list-style-type: none"> <li>• Frequency</li> <li>• Counter</li> <li>• Logic state</li> <li>• Sinusoidal inputs (IF11 – IF 12)</li> <li>• <math>V_{ALM}</math> sensor power supply</li> </ul>

In the above tables, consider that:

- $V_{ALM}$  is fixed voltage equal to battery voltage with current limitation of 200 mA
- $V_{PWR}$  is fixed voltage equal to battery voltage with current limitation of 2.5 A
- $V_{SWT}$  is voltage normally present but can be switched off at command; voltage equal to battery voltage with current limitation of 2.5 A

In addition to the terminal blocks described above, there is an ON/OFF switch on the casing and three status LEDs with the following meaning:

- ON flashes at each measurement cycle
- RUN indicates the internal watchdog status
- VBATT indicates the backup battery charge status (one flash means the battery is not charged; 5 flashes means the battery is fully charged).

With regard to the POWER SUPPLY connector, more than one power source can be used. The datalogger will subsequently handle any redundancy. For example, it is possible to connect the PS solar panel at the same time as the external 12V DC power input. The datalogger will then charge the battery through the solar panel or through the 12V DC input in absence of insolation.

The following paragraphs detail the electric and measuring characteristics of the various functional sections available in the terminal block.

## 2.3 Power supplies

---

The power supply section includes the connector named POWER SUPPLY and can manage three possible power sources:

- Solar panel
- 12V lead acid battery
- Nominal 12V bench power supply

The solar panel input is marked with **PS** (positive) and **GND** (negative) terminals and has the main function of keeping the power supply lead battery charged. Solar panels for charging 12V batteries are supported, with power up to 100W. In sunny conditions, the battery charger circuit forces the panel to work at a voltage of approximately 15.2V and can deliver up to 5A on the battery. The panel input is also equipped with:

- Reverse polarity protection circuit
- Low-pass filtering
- Electrostatic discharge protection circuit up to 30kV with peak power at 160W and IEC 61000-4-2 standards; level 4 (ESD); IEC 61000-4-5 (surge); IPP = 2.5 A; AEC-Q101

The battery input is marked with **BATT** (positive) and **GND** (negative) terminals and has the function of powering the datalogger. A lead acid battery with 12V nominal voltage can be connected to these terminals. The battery input is also equipped with:

- Reverse polarity protection circuit
- Electrostatic discharge protection circuit up to 30kV with peak power at 160W and IEC 61000-4-2 standards; level 4 (ESD); IEC 61000-4-5 (surge); IPP = 2.5 A; AEC-Q101

The bench power supply is marked with **VCC** (positive) and **GND** (negative) terminals and has the function, along with the battery, of powering the datalogger. A bench power supply with 12V nominal voltage, and in any case lower than 15V, can be connected to these terminals. The input is also equipped with:

- Reverse polarity protection circuit
- Electrostatic discharge protection circuit up to 30kV with peak power at 160W and IEC 61000-4-2 standards; level 4 (ESD); IEC 61000-4-5 (surge); IPP = 2.5 A; AEC-Q101

Finally, there is a power output supply on the connector that equals in value the battery voltage, useful for powering equipment that absorbs current such as radio modems and the like. The output is always present and marked with **12V** (positive) and **GND** (negative) terminals. The specific characteristics of the output are:

- 2.5A current limit with resettable fuse protection
- Electrostatic discharge protection circuit up to 30kV with peak power at 160W and IEC 61000-4-2 standards; level 4 (ESD); IEC 61000-4-5 (surge); IPP = 2.5 A; AEC-Q101

Other output voltages, always identical in absolute value to the supply voltage, are present, with different amperages, on each connector.

In particular, at the **12V** (positive) and **GND** (negative) terminals of the DIG OUT connector there is a power supply with identical amperages and characteristics to the power supply just described, with the only peculiarity that this output can be switched off at will with a MODBUS command.

On all the other connectors there is an output power supply, marked **12V**, which equals in absolute value the battery voltage and has the following characteristics:

- 200 mA current limit with resettable fuse protection
- Electrostatic discharge protection circuit up to 30kV with peak power at 160W and IEC 61000-4-2 standards; level 4 (ESD); IEC 61000-4-5 (surge); IPP = 2.5 A; AEC-Q101

These low power supplies are particularly useful for powering the sensors that must be acquired.

## 2.4 PT100 inputs

---

The DA18K control unit is equipped with four inputs with Pt100 acquisition functionality to connectors CH1, CH2, CH3 and CH4. In the expanded version, DA18KE, there are a further four inputs to connectors CH19, CH20, CH21 and CH22, capable of bringing the control unit's acquisition capacity to a maximum of eight Pt100 resistance thermometers<sup>3</sup>.

Measuring of the resistance thermometer value is done using the four-wire technique and involves terminals **I+** (excitation current generation), **Va** and **Vb** (measurement of the voltage at the ends of the resistance thermometer) and **I-** (excitation current return). The resistance thermometer is connected with one end at I+ and Va and the other end at I- and Vb. In particular, at each acquisition cycle an impulsive current<sup>4</sup> is generated at terminal I+ which, flowing on the resistance thermometer, creates a potential drop measured between inputs Va and Vb. The current closes on I- and generates a reference for the ratiometric measurement of the potential drop on the resistance thermometer.

Each Pt100 input also has the following characteristics:

- Electrostatic discharge protection circuit up to 20kV with peak power at 25W and IEC 61000-4-2 standards; level 4 (ESD); IEC 61000-4-5 (surge); IPP = 2.5 A on both the measuring inputs and on the return current for reference generation
- Differential low pass filtering with cutoff frequency of 530Hz

<sup>3</sup> The Pt100s are acquired on differential channels, therefore each Pt100 inserted takes away a differential channel from the total number of channels available.

<sup>4</sup> Only active for the measuring cycle so as not to alter the temperature conditions of the Pt100 (Joule effect).

- Common mode differential low pass filtering with cutoff frequency of 780Hz
- 24-bit resolution

## **2.5 Analogue inputs**

---

The control unit is equipped with a number of 24-bit analogue inputs, indicated on the connectors with Va and Vb, which are acquired both individually referred to ground and in pairs with differential input Va – Vb. In particular, the DA18K version has a total of 20 analogue inputs referred to ground that can be acquired at 10 differential inputs on connectors CH1 to CH16. The expanded version DA18KE has a further 8 inputs referred to ground that can be acquired as 4 differential inputs on connectors CH19, CH20, CH21 and CH22. All inputs have the following characteristics:

- Electrostatic discharge protection circuit up to 20kV with peak power at 25W and IEC 61000-4-2 standards; level 4 (ESD); IEC 61000-4-5 (surge); IPP = 2.5 A on both the measuring inputs and on the return current for reference generation.
- Differential low pass filtering with cutoff frequency of 530Hz
- Common mode differential low pass filtering with cutoff frequency of 780Hz
- 24-bit resolution

We will now look at the connector types for the 6-, 3- and 4-pin analogue inputs to better explain the connection options.

### **2.5.1 Analogue inputs on 6-pin connector**

---

The connectors of this type are CH1, CH2, CH3 and CH4, while the expanded version DA18KE has the additional connectors CH19, CH20, CH21 e CH22. They are multi-function 6-pin connectors in which you can connect, alternatively:

- One Pt100 resistance thermometer at terminals I+, Va, Vb, I-.
- One differential voltage signal between Va (positive) and Vb (negative)
- Two Va and Vb signals referred to ground

Refer to the technical specifications of the DA18K for the electrical ratings

On these connectors there is also a 12V low power supply (200 mA) as described in the previous paragraphs, to which you should refer for detailed information.

### **2.5.2 Analogue inputs on 3-pin connector**

---

The connectors of this type are CH5, CH6, CH7, CH8, CH9, CH11, CH12, CH13, CH14 and CH15; the expanded version DA18KE has the same connectors of this type.

On these connectors there is also a 12V low power supply (200 mA) as described in the previous paragraphs, to which you should refer for detailed information.

In addition to the two supply terminals described above, each connector has the left terminal, indicated with Va or Vb, which is an analogue input referred to ground. However, it is possible to use the connectors in pairs of two to acquire differential signals. In particular, the pairs CH5 – CH11, CH6 – CH12, CH7 – CH13, CH8 – CH14 and CH9 – CH15 can be used for the connection of a differential signal. In this case, Va indicates the positive terminal of the signal and Vb the negative one.

### 2.5.3 Analogue inputs on 4-pin connector

The connectors of this type are CH10 and CH16 are entirely identical to the 3-pin connectors in terms of Va and Vb functionality and their mode of use. A peculiarity of this connector type is the presence of:

- **Reference voltage**  
On both connectors the 2.5V terminal indicates a 2.5V reference useful for measuring, for example, potentiometer signals such as wind direction.
- **Analogue output**  
On CH10 the **OA1** terminal indicates a 12-bit 0 – 2.5V analogue output settable with MODBUS command. On CH16 the analogue terminal is indicated by **OA2**.

### 2.5.4 Analogue inputs configurable in 4 – 20 mA

The DA18K datalogger, as well as the DA18KE, has four of the described analogue inputs that can be configured to acquire current signals in the range 4 – 20mA without resorting to the use of external precision resistors. These 100Ω resistors are already included in the DA18K, allowing conversion of 4 – 20mA current signals into 0.4 – 2V voltage signals. The channels set up for this functionality are CH8, CH9, CH14 and CH15. To enable the resistor, the user must unscrew the processing electronics housing from the one below (see the figure below), enabling access to four switches, each of which enables the resistor on the relative acquisition channel.

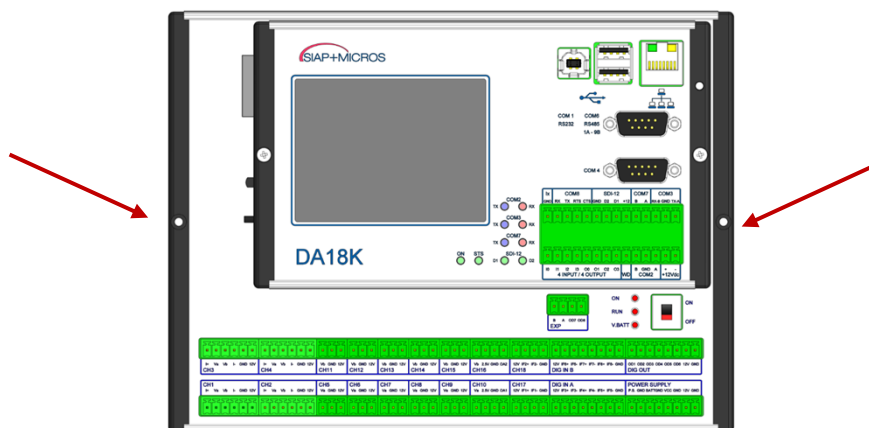

## 2.6 Digital inputs

The acquisition base of the control unit is equipped with eight digital inputs to connectors CH17, CH18, DIG IN A and DIG IN B. The inputs are intended as pairs, so the pair (IF1+ ÷ IF1-) on CH17 is one input, and so on for all the others.

Particular characteristics of these inputs are:

- Pair of opto-isolated inputs with 5KV<sub>RMS</sub> isolation voltage
- 10kΩ internal resistance limit
- Automatically acquired every second, such as:
  - Frequency
  - Count
  - Logic state

The circuit diagram of the input is shown in the illustration below:

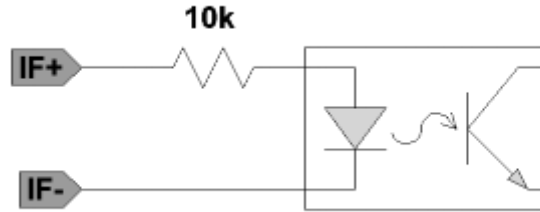

The input type allows to acquire both square wave signals, by connecting IF- to ground and IF+ to signal positive, and dry contacts. In the latter case it is necessary to bring supply voltage to IF+ to polarise the photodiode and connect the dry contact to IF-. For this purpose, the 12V power supply is brought to the connectors. For example, a dry contact connected on CH17 must be wired with a bridge between the **12V** terminal and the **IF1+** terminal, and the dry contact can therefore be connected between **IF-** and **GND**. When the contact is open, there is no current flowing on the photodiode and the signal transmitted to the datalogger is read as high logic state due to the internal pull-ups. When the contact closes to ground, a current flows on the photodiode and the signal transmitted to the datalogger is read as low logic state.

In the case of dataloggers with DA18KE expansion, there are a further eight opto-isolated digital inputs like the previous ones, to which four comparator inputs for AC sensors are added<sup>5</sup> (for example, with variable reluctance). These inputs, however, are positioned differently on the connectors concerned. In particular, the channels are subdivided among the connectors as follows:

- CH17
  - IF1 opto-isolated digital input
- CH18:
  - IF2 opto-isolated digital input
- DIG IN A:
  - IF3, IF4 and IF5 opto-isolated digital inputs
- DIG IN B
  - IF6 opto-isolated digital input
  - IF7, IF8 differential comparator inputs
- CH19:
  - IF9 opto-isolated digital input
- DIG IN C:
  - IF10 opto-isolated digital input
  - IF11, IF12 differential comparator inputs

We have already mentioned the opto-isolated inputs while the other type of input has a differential comparator which, given the sinusoidal wave at the input, produces a square wave of the same frequency used for acquisition. This peculiarity allows to accommodate passive sensors like some wind sensors with sinusoidal wave output. As for the opto-isolated inputs, these inputs can also be read as frequency, count or logic state and are equipped with an electrostatic discharge protection circuit up to 23kV with peak power at 500W and IEC 61000-4-2 standards; level 4 (ESD); IEC 61000-4-5 (surge); IPP = 18 A.

In addition to these inputs, there are four more inputs on the 28-pin connector of the processing and control part of the control unit. These inputs are also opto-isolated with 3.75kV isolation voltage but can only be read as status inputs.

<sup>5</sup> For example, variable reluctance sensors such as some wind speed sensors.

To summarise, the DA18K has 8 opto-isolated mixed type digital inputs (frequency, count, state) and 4 opto-isolated status digital inputs. The expansion adds to these inputs 4 further mixed digital inputs (frequency, counter, state) for sinusoidal inputs.

## 2.7 Digital outputs

---

The acquisition base of the control unit is equipped with eight open drain digital outputs, six on the DIG OUT connector and two on the EXP connector. Each digital output has the following characteristics:

- Open drain type with resistance limit from  $1\Omega$  – 0.25W
- Maximum current 500mA
- Electrostatic discharge protection circuit up to 25kV with peak power at 350W and IEC 61000-4-2 standards; level 4 (ESD) 15kV (air) 8kV (contact), IEC 61000-4-4 (EFT) 40 A (5/50 ns), IEC 61000-4-5 (lightning) 23 A (8/20 $\mu$ s).

On the 28-pin connector of the processing and control unit there are a further four digital outputs, O0, O1, O2, O3 with the following characteristics:

- Open collector type
- Maximum current 100 mA
- Electrostatic discharge protection circuit up to 30kV with peak power at 200W and IEC 61000-4-2 standards (ESD) 30kV (air) 30kV (contact), IEC 61000-4-4 (EFT)

## 2.8 Connectivity

---

The DA18K has a wide range of communication devices such as RS-232, RS-485, Ethernet, USB, etc. In the following paragraphs we will analyse the characteristics of the various communication interfaces.

### 2.8.1 RS-232 serial interfaces with criteria: COM1, COM4, COM8

---

The control unit is equipped with three RS-232 type interfaces with criteria, i.e. that in addition to transmit and receive, have carried other control signals on the interface connector. These are:

- **COM1**  
9-pin D-SUB connector to which the 2, 3, 5, 7 and 8 pins of the connector are carried, i.e. the RX, TX, GND, RTS and CTS signals.
- **COM4**  
9-pin D-SUB connector to which all connector signals are carried, i.e.: DCD, RX, TX, DTR, GND, DSR, RTS, CTS, RI.
- **COM8**  
Is part of the 28-pin connector and carries the RX, TX, RTS and CTS signals.

On these, it is possible to connect communication devices such as cellular modems, radio interfaces, etc. They can also be used for direct connection to a configuration terminal such as a personal computer. In the latter case, the datalogger and the computer must be connected via NULL MODEM cable, i.e. with the two ends both D-SUB 9-pin female terminals and with pins two and three reversed in such a way that the computer transmission arrives to the datalogger reception and vice versa.

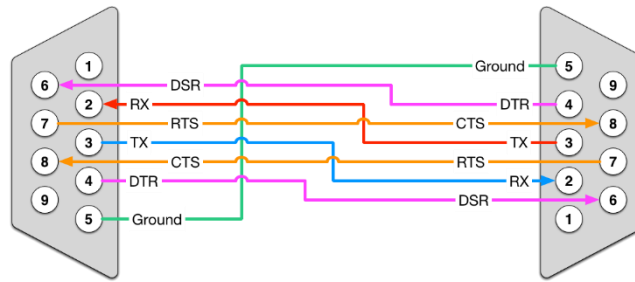

Regarding the protections, each RS-232 serial port is equipped with an electrostatic discharge protection circuit up to 15kV (IEC 61000-4-2 Air Gap and Human Body Model).

### **2.8.2 RS-485 serial interfaces: COM2, COM6, COM7**

The datalogger has three dedicated serial communication interfaces for the connection of RS-485 devices:

- **COM2**  
 Is part of the 28-pin connector and has signals A, B and ground. B has a 4.7kΩ pull-down to ground while A has a 4.7kΩ pull-up to the internal power supply. This interface is also shown internally on the acquisition base below the EXP connector, terminals **B** and **A**, and is used by the processing and storage unit to retrieve the data acquired from the acquisition base.
- **COM6**  
 Is part of a 9-pole D-SUB connector, the same as COM1, with A at pin 1 and B at pin 9. B has a 4.7kΩ pull-down to ground while A has a 4.7kΩ pull-up to the internal power supply.
- **COM7**  
 Is part of the 28-pin connector and has signals A and B. B has a 4.7kΩ pull-down to ground while A has a 4.7kΩ pull-up to the internal power supply.

The interfaces can be used for the acquisition of sensors or to communicate with devices with RS-485 interface. The interfaces are equipped with electrostatic discharge protection circuit. In particular:

- On the 28-pin connector and on the D-SUB there are electrostatic discharge protection circuits up to 30kV with IEC 61000-4-2 reference standards, ±30 kV contact discharge, ± 30 kV air discharge, AEC-Q101: human body model class H3B > 8 kV
- On the EXP connector there is an electrostatic discharge protection circuit up to 30kV and IEC 61000-4-2 regulations, 30kV (air) 30kV (contact), IEC 61000-4-4 (EFT) 50 A (5/50 ns), IEC 61000-4-5 (lightning) 19A (8/20μs).

### **2.8.3 RS-232 and RS-485 hybrid serial interfaces: COM3**

The DA18K is equipped with a hybrid serial port, COM3, which can be either RS-485 or RS-232. The choice must be specified at the time of ordering as this port is usually configured as RS-485 while the RS-232 configuration is an optional. The corresponding terminals on the 28-pin connector of the processing and testing control unit are:

- **RX – B:** B (negative) of RS-485 or reception of RS-232 if requested.
- **GND:** ground
- **TX – A:** A (positive) of RS-485 or transmission of RS-232 if requested.

Any pull-ups or pull-downs must be inserted externally.

The interface, if used as RS-485, is equipped with is an electrostatic discharge protection circuit up to 30kV with IEC 61000-4-2 reference standards,  $\pm 30$  kV contact discharge,  $\pm 30$  kV air discharge, AEC-Q101: human body model class H3B > 8 kV.

If used as RS-232, it is equipped with an electrostatic discharge protection circuit up to 15kV (IEC61000-4-2 Air Gap and Human Body Model).

### **2.8.4 SDI-12 interfaces: COM5, COM9**

---

On the 28-pin connector there are two communication interfaces for sensor acquisition according to the SDI-12 communication standard. The interfaces consist of terminals:

- **+12**: 12V sensor power supply with 100mA limit according to the standard
- **D1**: 5V COM5 data line.
- **D2**: 5V COM9 data line.
- **GND**: power supply ground.

The 5V data line, as required by the standard, is left in high impedance via a three-state buffer when not used. This line also has an electrostatic discharge protection circuit up to 30kV with IEC 61000-4-2 reference standards,  $\pm 30$  kV contact discharge,  $\pm 30$  kV air discharge, AEC-Q101: human body model class H3B > 8 kV.

### **2.8.5 Network interface**

---

There is an ethernet connector to which a 10/100 Mbps base T network card is connected, managed at low level by the Windows CE embedded operating system. The electrostatic discharge immunity characteristics for this interface are:

- $\pm 4$  kV Human Body Model according to ANSI/ESDA/JEDEC JS-001 standard
- $\pm 1$  kV Charged Device Model according to JEDEC JESD22-C101 specifications

### **2.8.6 USB host interfaces**

---

There is a type A female USB host interface to which you can connect devices such as a memory stick, keyboard, mouse, etc.

The interface is equipped with a dedicated transient voltage supply circuit specific to USB signal characteristics. The circuit is also protected against electrostatic discharges up to 15kV according to the IEC 61000-4-2 standards and in particular:

- $\pm 15$  kV Human Body Model
- $\pm 2$  kV Machine Model

### **2.8.7 USB slave interfaces**

---

There is a type B female USB slave interface for connecting and accessing the file system of the datalogger. In particular, for Windows systems the DA18K is recognised as a Windows mobile device and it is possible to access the file system through the "Windows mobile device management centre" which, if not already available in the installed version of Windows, can be obtained free of charge from the Microsoft website. Windows ActiveSync can also be used for the same purpose.

The interface is equipped with a dedicated transient voltage supply circuit specific to USB signal characteristics. The circuit is also protected against electrostatic discharges up to 15kV according to the IEC 61000-4-2 standards and in particular:

- $\pm 15$  kV Human Body Model
- $\pm 2$  kV Machine Model

## **2.9 External storage unit and display**

---

In the normal cycle of use, the collected data is stored in the internal memory of the device (non-volatile flash memory). It is, however, possible to make a copy of the data on an external storage device. On the side of the datalogger display there is an SD card connector that can house a backup SD Card storage device, which is managed automatically by the Windows CE embedded operating system that recognises it as an external hard drive<sup>6</sup>. If the overall storage capacity needs to be increased, there is an internal SD Card connector with the same type of use. It is also possible to select a USB pen drive mounted on one of the USB host connectors and use it as a data storage hard drive<sup>7</sup>.

The display is a 3.5" TFT-LCD touchscreen with 320 x 240 resolution and 16 million colours. It is transmissive with white backlight<sup>8</sup>.

The display provides graphic interface to the Windows CE operating system, enabling user interaction with the management programme. More details are given in the following paragraphs.

---

<sup>6</sup> The greater the SD card capacity, the longer it will take for initial recognition.

<sup>7</sup> The greater the pen drive capacity, the longer it will take for initial recognition.

<sup>8</sup> If not piloted it is normally white.

### 3 Use and programming guide

---

The following chapter gives an overview of the programming and use of the DA18K control unit. In particular, it describes the architecture and functionalities of the internal management software (datalogger programme). The programme implements the typical functions of the datalogger such as the acquisition of measuring sensors, recording of processed data and its transmission through the communication peripherals.

#### 3.1 Operating system

---

The DA18K device is equipped with Microsoft® Windows® CE 6.0 embedded operating system.

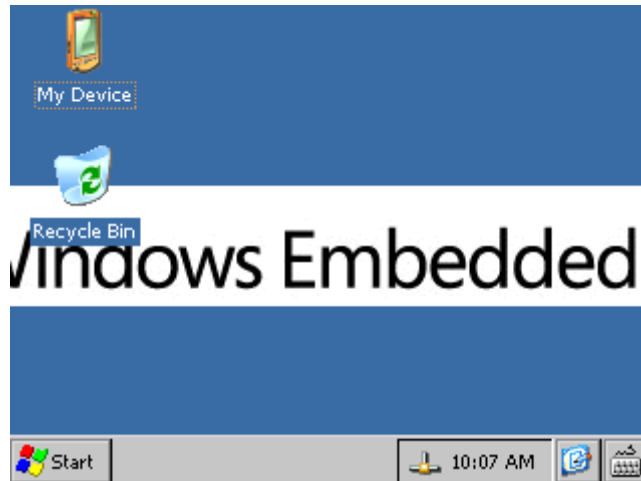

The operating system is factory-installed with the following settings:

Memory drives:

- **NandFlash**  
Non-volatile internal flash memory (215MB capacity)
- **SD Memory Card on Slot A**  
Removable SD card type memory medium (256MB or 512MB capacity)

Programme folder:

- **\NandFlash\DA9000**  
Installation folder of the datalogger programme (contains the operating application DA9000.exe and the files necessary for operation)
- **\NandFlash\TOOLS**  
Service application programmes folder (utility & tools)

### 3.1.1 Network connections

The Windows CE embedded operating system allows to manage network and dial-up modem connections. To display and set connections, select **Settings > Network and Dial-up Connections** from the Start menu:

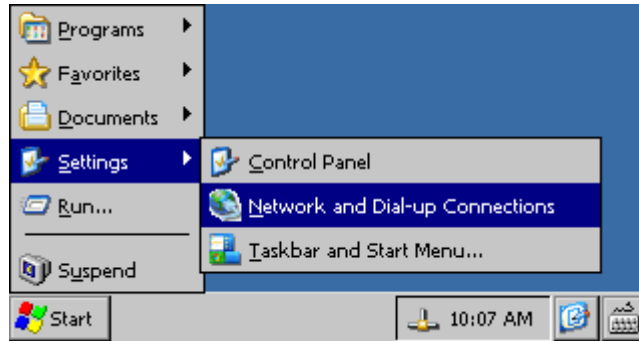

The following connections are normally available:



**EMACB1**  
 Network card connection (LAN)



**INTERNET**  
 Default dial-up connection for remote access (RAS) via RS-232 modem

The corresponding properties are displayed by selecting the desired connection with a double click.

#### Network connection settings (EMACB1)

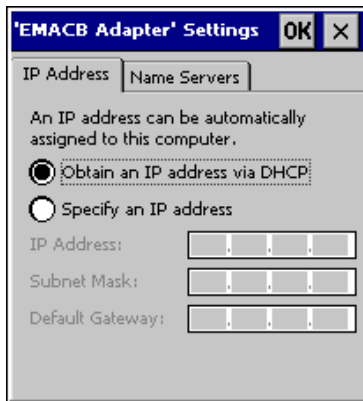

The **EMACB Adapter** network card is normally set to automatically obtain an IP address via DHCP server (in networks where available).

Otherwise, it is possible to specify the parameters necessary to connect to the network:

- IP Address
- Subnet Mask
- Default Gateway

#### Dial-up connection settings (INTERNET)

The connection called **INTERNET** is the default dial-up connection created on DA18K to obtain remote access to the Internet (RAS) via an RS-232 serial device. The connection is normally used with a GPRS/EDGE/UMTS modem for mobile networks connected to the COM4 port of the datalogger (modem: *Hayes Compatible on COM4*).

The default settings of the modem serial port are:

- Baud Rate: **38400** bps
- Data Bits: **8**
- Parity: **None**
- Stop Bits: **1**

- Flow Control: **Software**

The telephone number used for anonymous connection to the Internet is: **\*99\*\*\*1#**



The procedure to recreate the above connection, if not present or if deleted by the system, is as follows:

Creation of the INTERNET modem dial-up connection

1. Double click *Make New Connection...*
2. Type the connection name **INTERNET**
3. Select *Dial-Up Connection* and press *Next >*
4. Select the modem **Hayes Compatible on COM4** and press the *Configure* button.
5. Set the port parameters (Baud Rate: **38400**, Data Bits: **8**, Parity: **None**, Stop Bits: **1**, Flow Control: **Software**) and press *OK*
6. Press *Next >*
7. Set the telephone number **\*99\*\*\*1#** and press *Finish*
8. Finally, run *Start... Suspend* and press the side button **STAND BY OFF**

### 3.1.2 Saving settings

All changes made to the control panel of the operating system (connection settings, display settings, passwords, etc.) are saved in the Windows registry but become permanent only after being saved in the internal flash memory.

This save task is made explicit through the Windows CE suspend function, therefore after each change and in any case before a restart, it is good practice to suspend the device, otherwise the settings made will be lost the first time the device is shut down.

To save changes to the system, select **Suspend** from the Start menu:



The device will enter suspend mode and will turn off the display. To restart the system, press the **STAND BY OFF** button on the left side of the datalogger.

### 3.2 Programme start

The datalogger programme (or firmware) resides in the executable file **DA9000.exe** in the \NandFlash\DA9000" folder of the device. The programme runs automatically after Windows CE start-up via a link to the Start.exe application (located in \NandFlash\Windows\StartUp). Any other programmes required for operation will also be started automatically at datalogger power on.

To switch on the DA18K datalogger, switch on the analogue base. The ON LED will start flashing and after a few moments the device will start to load the operating system:

#### Loading Operating System...

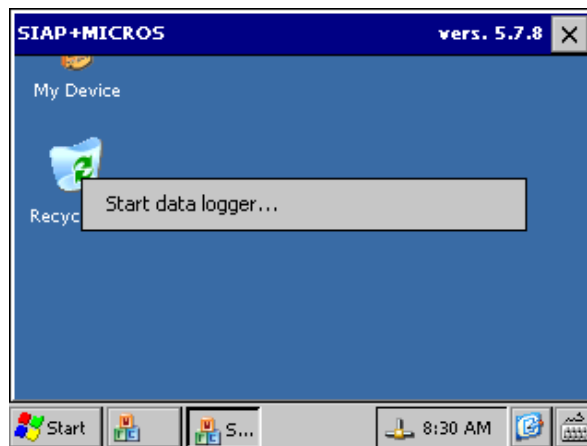

Wait about one minute for the operating system and the programme to load, after which the display will show the main measurement page (see section 3.4 *Display pages*).

On first start-up, the system will create the following sub-folders:

- \NandFlash\DA9000\Logs containing the log files of the machine (last 7 days of operation).
- \NandFlash\DA9000\Archivio containing the data storage areas (internal flash memory)
- \SD Memory Card on Slot A\BackUp containing the backup files of the data and logs (removable external memory).

### 3.3 Clock settings

To obtain an accurate time reference, the datalogger has an on-board real time clock (RTC). The RTC device is used to periodically synchronise the internal clock of the Windows CE system.

At first start-up, the RTC clock and system clock may not be set because the internal power supply (battery) is normally disconnected from the protection tab. In this case, the system will show the following warning message:

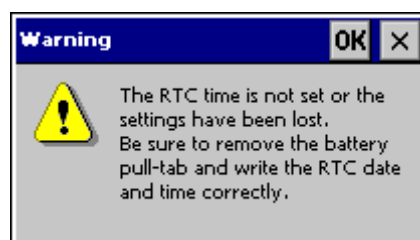

Remove the battery tab and press OK to set the date and time.

The RTC service programme for clock setting will be loaded. Enter the correct date and time and press the WRITE button to confirm the entry:



Finally, close the RTC window.

**Note on the time zone**

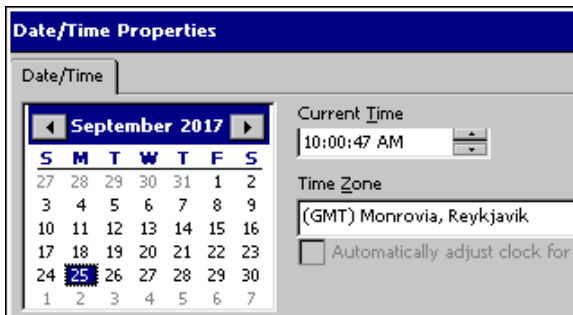

For correct operation of the datalogger, keep the time zone settings to:

**(GMT) Monrovia, Reykjavik or (GMT) Casablanca**

without automatic daylight-saving adjustment.

**3.4 Display pages**

The display of the DA18K control unit consists of six display pages which show the user information about the measurements acquired and the datalogger status. The information displayed depends on the settings made and the configuration loaded.

**3.4.1 Measures**

The *Measures* tab shows the list of measures in acquisition and/or displayed data. The list only contains the items configured for display and is updated by default every 3 seconds. The lower part of the window shows the ID and the name assigned to the datalogger station.

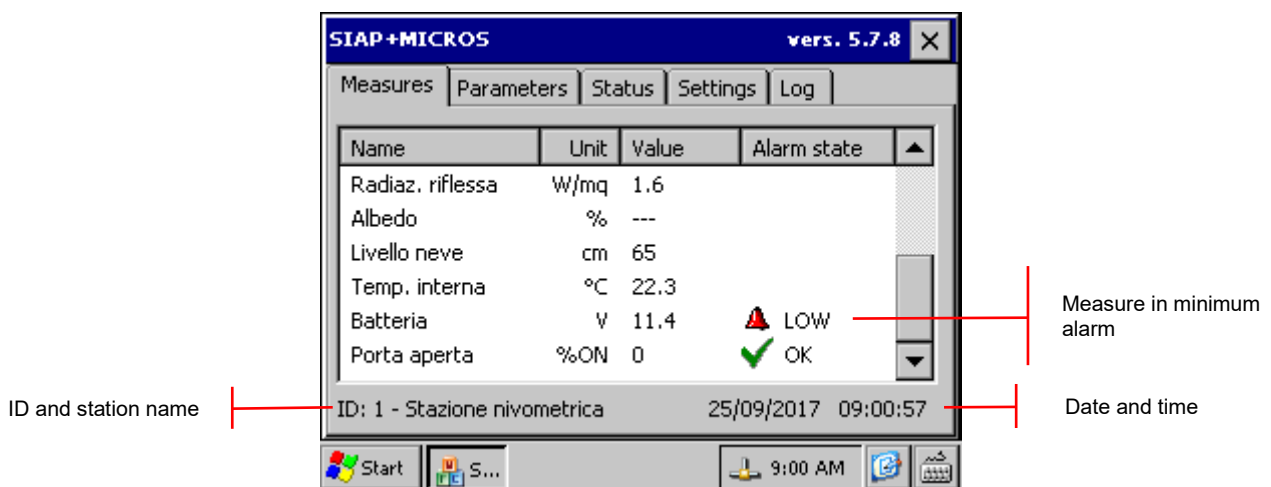

In detail, the fields in the measures list are:

- *Name* Name of the measure or data displayed;
- *Unit* Engineering unit;
- *Value* Value;
- *Alarm state* Alarm state (only if associated);

The alarm state can only appear is an alarm control is associated to the specific measure, otherwise the field will be left empty.

The possible alarm states are:

- ✓ OK Measure OK
- ⚠ WARNING LOW / HIGH Measure in minimum/maximum pre-alarm
- 🚨 LOW / HIGH Measure in minimum/maximum alarm
- ✖ ERROR / OVER RANGE Acquisition error / Measure out of range
- ⚠ STOP Sensor in maintenance

### 3.4.2 Data

By selecting the *Data* tab you can extract and view the archive data. The initial window will show a tabular report with the data stored for the current day. The user can change the day by selecting the date from the calendar in the bottom left corner:

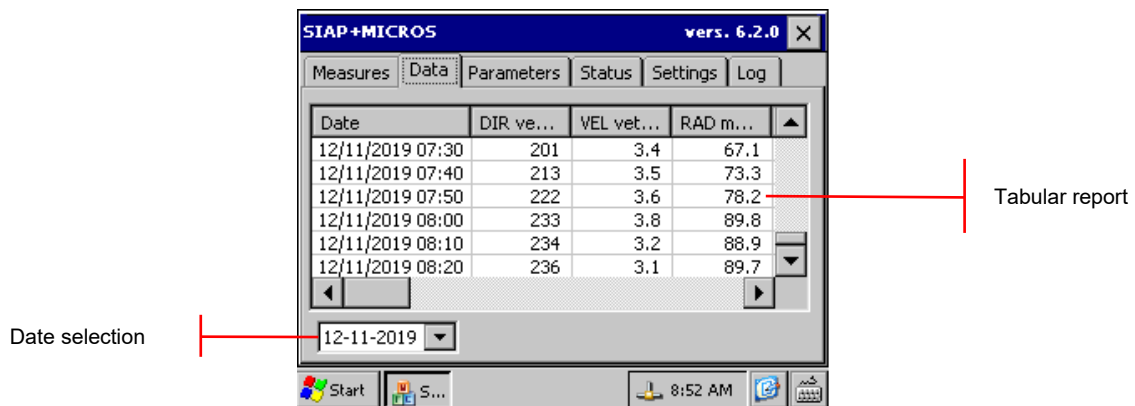

Note that the report will only be displayed if previously enabled in configuration and will only contain the fields configured for display. It is possible to enable in display only one data archive at a time (e.g. statistical data of file no. 6).

If no archive is enabled, the information message “No data configured to display” will be shown.

### 3.4.3 Parameters

The *Parameters* page displays the user parameters in the configuration and allows direct modification of the values via the touch screen keypad. A numeric ID, a description and an engineering unit are associated to each parameter.

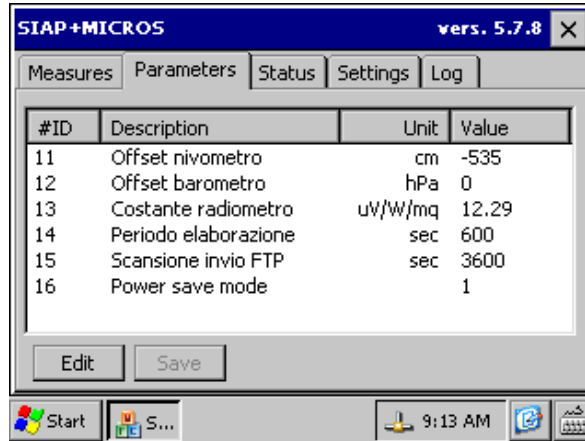

To change one or more parameters, proceed as follows:

1. Press the Edit button to start (the system's alphanumeric keypad will automatically open).
2. Select the value to be changed.
3. Enter the new value.
4. Press the Close button to finish changes (the keypad will close).
5. Lastly, save changes using the Save button (a confirmation message will be displayed).

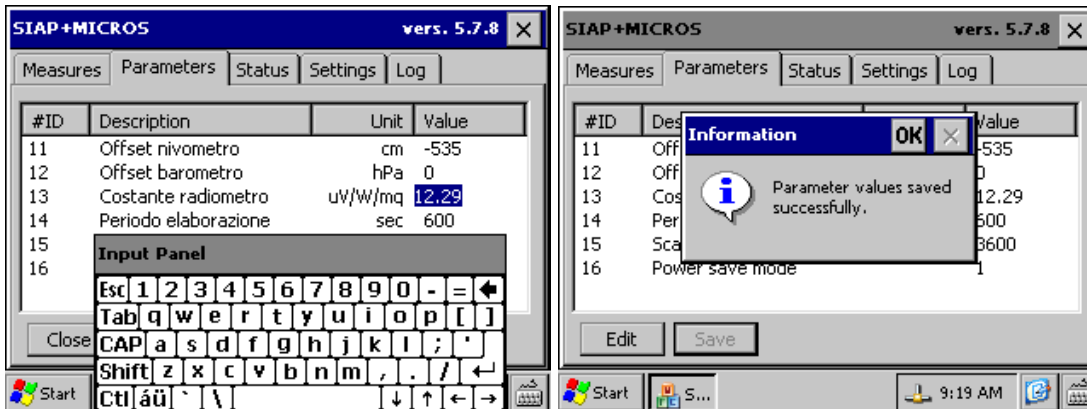

Editing operations can also be performed using a keyboard and a USB mouse.

### 3.4.4 Status

The top part of the window displays the current status of the following connections:

- RAS dial-up modem connection (INTERNET)
- TCP/IP connection to TUNNEL server

The following example show the states of a datalogger configured for connection to the Internet via RAS and a permanent TCP/IP connection to a TUNNEL server:

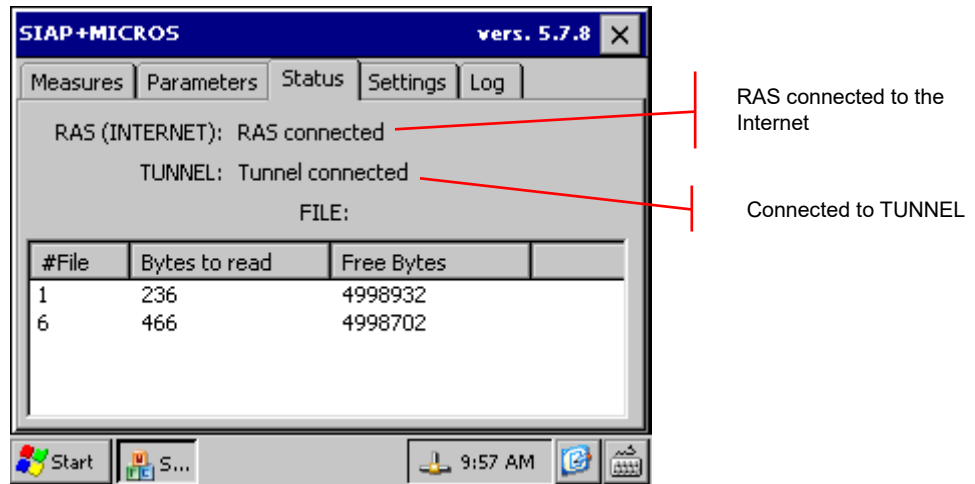

The bottom part of the window shows the number of archive files configured for storage. For each archive, the quantity (in bytes) of data still to be read/transferred (Bytes to read) and the space available for storage (*Free Bytes*) is shown in real time.

### 3.4.5 Settings

The *Settings* page displays the system initialisation settings of the DA18K. Specifically:

- Maximum size of data files (bytes).
- Communication speed and protocol for the dialogue-enabled serial ports (COM1..COM4).
- Port and communication protocol for incoming TCP/IP connection.
- Communication address and protocol for connecting to a TUNNEL server.
- Root path where the data archive resides.
- Life signal activation period on the watchdog (WD) output.
- Time interval for updating the system clock (RTC).
- Server and interval for time synchronisation (Time Protocol), if any.

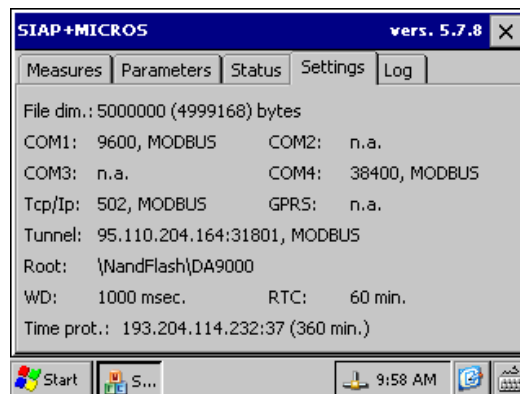

### 3.4.6 Log

This window displays in real time the messages of events recorded by the programme during operation. The main messages are:

- Information about the programme and individual threads started
- Errors in data acquisition and/or alarms on acquired measures
- States of output connections (GPRS, RAS, TUNNEL signal, etc.)
- Errors in data recording and/or communication (data backup, sending via FTP, etc.)
- Clock synchronisation events
- Configuration or firmware update events

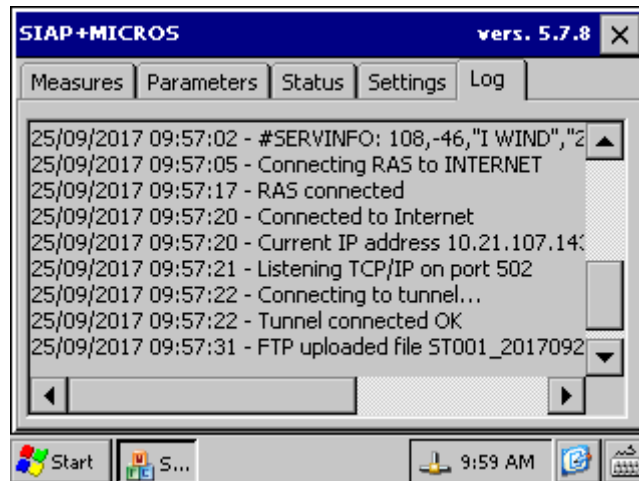

The user can scroll through the messages via the vertical/horizontal bar displaying the time events since the datalogger was started.

## 3.5 Description of functions

The operating modes of the datalogger and the parameterisation of the user-configurable functions are described below.

### 3.5.1 Initialisation and configuration file

At start-up, the programme loads the system settings and configuration parameters to be used during operation. This information is contained in the following files:

- **INI.xml** System initialisation
- **CNF.xml** Configuration file

Both files are needed to start the datalogger and must reside in the \NandFlash\DA9000 folder of the device. A blocking error will be generated if they are not present.

The content of the files is structured in XML language and is normally compiled and sent to the datalogger by a configuration management software. By way of example, examples of files displayed by a text editing programme are shown.

The initialisation file *INI.xml* is used for the base system settings and communication with the datalogger.

Example of an *INI.xml* file:

```

<?xml version="1.0" encoding="ISO-8859-1"?>
<!--Setting created by S+M DAK v 2.7 on 02/ott/2017 15:00:00-->
<SYSTEM>
  <INI idstaz="1" id_mem="1" id_sms="" name="Stazione nivometrica">
    <FILE size="5000000"/>
    <ROOT path="NandFlash\DA9000"/>
    <BACKUP enable="1" path="SD Memory Card on Slot A" path2="" local="0"/>
    <COM1 baud="9600" protocol="2" rts="3"/>
    <COM4 baud="38400" protocol="2" rts="3"/>
    <TCP/IP port="502" protocol="2"/>
    <TUNNEL ip="95.110.204.164" port="31801" scan="10" echo="A" mem_state="2" protocol="2"/>
    <TimeProtocol ip="193.204.114.232" port="37" scan="360" timezone="1"/>
    <RTC scan="60"/>
    <WD scan="1000" runtime="300" countdown="21600"/>
    <RAS entryname="INTERNET" always-on="0"/>
    <CHECK URL="http://www.google.com"/>
    <TETRA-SDS pid="0"/>
    <ENERGY-SAVING enable="0" wait="0"/>
    <MODEM info="AT#SERVINFORM"/>
  </INI>
</SYSTEM>
  
```

The system settings are contained within the <SYSTEM> and <INI> elements. If not present, the initialisation file is considered invalid.

All the system initialisation parameters are described below. Some parameters may assume default values if they are omitted in the file.

System initialisation parameters:

- **idstaz**: communication hardware identification of the datalogger station (1 ÷ 254, default = "1");
- **id\_mem**: data record storage/transmission identification (default = **idstaz**);
- **id\_sms**: storage identification for SMS record report (obsolete);
- **name**: name of the datalogger station (displayed on the first page of the display).
- **ROOT path**: path of the main folder in which the data archive and log operation folders are created (\Archive and \Log). Folder creation follows the scheme below:
  - If the **ROOT** field is not present or the **path** is not specified, the \Log and \Archive folders will be created in the folder of the DA9000 executable programme. 0;
  - If the **ROOT** field is present but the **path** is invalid, the log error will be reported and the acquisition cycle will still start;
  - If the **ROOT** field is present and the **path** is valid, the \Log and \Archive folders will be created correctly.
- **FILE size**: common size of the data archive files. The attribute specifies the bytes that will be converted to an integer multiple of 1024. So if, for example, a size of 5000000 bytes (equal to 5MB) is specified, the number of bytes that will actually be used in the programme is 4999168.
- **BACKUP path**: path of the primary backup unit in which the daily historical data is copied. The backup function creates daily incremental files that contain a copy of historical data for each archive file; **path2**: path of the secondary backup unit (optional); **enable**: allows to enable or disable the backup without altering path settings (enable = "1" backup enabled, enable = "0" backup disabled); **local**: maximum number of days of local backup maintenance (default = "30");
- **EXT source**: specifies the presence of an external file to copy to an internal data file. The **source** field specifies the path of the source file, the **file** field is the number of data files on which the copy will be made (obsolete setting for image file management).
- **WEBSERVER**: enables management of the Internal webserver of the datalogger (**enable**="1"). Specify the **port**=8080, and **username** and **password** required to execute commands.
- **SMTP**: e-mail SMTP server settings. Specify: the name of the server and the connection port; the type of security used (SSL / TLS, STARTTLS); the username and password of the account; the sender (optional).

- **COMx**: setting of the serial port active in receiving the communication protocol (*interrupt*). For every activated port, the communication speed in **baud** and the **protocol** with which it is possible to communicate, is specified (default: COM1 baud="9600" protocol="1" rts="3").

The basic protocol is 1 = *Store&Forward*, 2 = *Modbus RTU*, 3 = *Tetra SDS*.

**dtr**: signal configuration DTR: "0" (Disable), "1" (Enable), "2" (Handshake). Default = "0" .

**rts**: signal configuration RTS: "0" (Disable), "1" (Enable), "2" (Handshake), "3" (Toggle). Default = "3".

**sync** additional setting for the number of initial synchronisms (character 0x16). Default = "10".

- **TCPIP port**: setting for opening an incoming TCP/IP connection (listening socket on the **port** specified in the communication **protocol**).
- **TUNNEL**: definition of the TCP/IP connection to a remote tunnel server. Specify the server **IP** address and the **port** of the listening socket, the **echo** character (default = "A") to be sent periodically with **scan** to keep the connection active. Specify the communication **protocol** to be used. The default location where the connection status is stored is **mem\_state="2"**. Normally, if the connection is active the status is 1, otherwise if there is no connection the status is set to -9999 (invalid).
- **GPRS**: (obsolete) manages the TCP/IP connection to the tunnel server using the GPRS/EDGE/UMTS modem commands. It is necessary to specify the serial COM port on which the modem is connected, the AT **commands** for initialisation and opening of the connection, then the **echo** character (default = "A") to be sent periodically with **scan** to keep the tunnel active. The **timeout** field determines the maximum time, in seconds, to wait before retrying the connection. The connection status is kept in the location specified in **mem\_state** (active connection: status=1, inactive connection: status= -9999).
- **RAS entryname**: name of the remote access connection to the Internet (RAS). Runs a dial-up connection via GPRS/EDGE/UMTS serial modem (see Windows CE operating system network connections). The connection is made when it is necessary to transmit data via the Internet otherwise it remains active only if there is a tunnel connection. The **always-on** flag forces the RAS connection to be always active.
- **CHECK URL**: specifies a URL or remote IP used to check the Internet connection.
- **MODEM info**: specifies an additional AT command to be sent to the modem to obtain information about the RSSI signal, telephone operator, etc.
- **TimeProtocol**: configures the clock synchronisation via Internet specifying the **IP** address of the *Time Server* and the **port** to connect to. A **scan** time in minutes must also be specified to define how often to perform synchronisation, as must the **time zone** used. When the time is obtained, the datalogger updates both the RTC clock and the system clock.
- **RTC scan**: sets the synchronisation of the system clock with the second RTC clock. The **scan** interval must be specified in minutes.
- **WD scan**: sets the pulse **scan** period (seconds) on the WD digital output of the datalogger. It is also possible to specify (in seconds) the control over the maximum time of the main cycle (e.g. **runtime="60"**) and the control over the maximum data download interval (e.g. **countdown="86400"**) at the end of which the process deactivates the WD pulse allowing the external watchdog to intervene and reset the datalogger. NB: set **countdown = "0"** to disable the maximum data download time control.
- **ENERGY-SAVING**: energy saving management of the datalogger. Automatically suspends the system and awakens it periodically to perform the functions programmed during configuration. Set **enable="1"** to enable the energy saving function and **wait** (seconds) for the dwell (or waiting) time before suspension.

The *CNF.xml* configuration file contains the functions and parameters programmed by the user for the datalogger work cycle. These are contained in the following XML sections:

<PARAMETERS>

<ACQUISITIONS>

<PROCESSING>

<CONTROLS>

<STORAGES>

<TRANSMISSIONS>

<DISPLAY>

Example of a *CNF.xml* file:

```

<?xml version="1.0" encoding="ISO-8859-1" ?>
<!--Configuration created by S+M DAK v 2.7 on 14/dic/2017 16:00:00-->
<CONFIG>
  <REMARKS>
    <REMARK name="1.2" ClsId="REMARK" author="De Nardi" note="Stazione Nivometrica"/>
  </REMARKS>
  <PARAMETERS>
    <PARAMETER name="Offset nivometro" ClsId="PARAMETER" id="11" unit="cm" value="-535"/>
    <PARAMETER name="Offset barometro" ClsId="PARAMETER" id="12" unit="hPa" value="0"/>
    <PARAMETER name="Costante radiometro" ClsId="PARAMETER" id="13" unit="uV/W/mq" value="12.29"/>
    <PARAMETER name="Periodo elaborazione" ClsId="PARAMETER" id="14" unit="sec" value="600"/>
    <PARAMETER name="Scansione invio FTP" ClsId="PARAMETER" id="15" unit="sec" value="3600"/>
    <PARAMETER name="Power save mode" ClsId="PARAMETER" id="16" unit="" value="1"/>
  </PARAMETERS>
  <ACQUISITIONS>
    <SENSOR name="BASE15K - Ingressi analogici" ClsId="BASE15KAI" type="4" id_hw="1" com="2" baud="57600" scan="3" funct="04" address="0001">
      <CHANNEL name="TA" ClsId="PT100_CH01" id="1" type="3" expr="M0-15" min="-40" max="60" mem_ist="21"/>
      <CHANNEL name="RAD" ClsId="DIFF_CH03" id="13" type="3" expr="(M0/$13)" min="-20" max="2000" mem_ist="30"/>
      <CHANNEL name="REF" ClsId="DIFF_CH04" id="15" type="3" expr="(M0/$13)" min="-20" max="2000" mem_ist="31"/>
      <CHANNEL name="RH" ClsId="SING_CH05" id="17" type="3" expr="(M0*1e-6)*100" min="0" max="110" mem_ist="29"/>
      <CHANNEL name="DIR" ClsId="SING_CH06" id="19" type="3" expr="(M0*1e-6)*(359/2)" min="0" max="360" mem_ist="35"/>
      <CHANNEL name="PPS" ClsId="SING_CH11" id="29" type="3" expr="(M0*1e-6)" min="-1" max="3" mem_ist="25"/>
      <CHANNEL name="TI" ClsId="TEMP_INT" id="41" type="3" expr="" min="-40" max="60" mem_ist="45"/>
      <CHANNEL name="VEL" ClsId="FREQ_CH17" id="43" type="3" expr="(M0/3.36)" min="0" max="60" mem_ist="36"/>
      <CHANNEL name="IC" ClsId="I_CHARGE" id="75" type="3" expr="" min="0" max="10000" mem_ist="58"/>
      <CHANNEL name="IB" ClsId="I_BATT" id="77" type="3" expr="" min="0" max="5000" mem_ist="59"/>
      <CHANNEL name="BATT" ClsId="V_BATT" id="79" type="3" expr="" min="0" max="24" mem_ist="48"/>
    </SENSOR>
    <SENSOR name="BASE15K - Stati digitali" ClsId="BASE15KDI" type="4" id_hw="1" com="2" baud="57600" scan="3" funct="02" address="0001" regi>
      <CHANNEL name="DOOR" ClsId="STATE_DIA04" id="4" type="0" conv="M0=0" expr="M0*100" min="0" max="100" mem_ist="60"/>
    </SENSOR>
    <SENSOR name="Preelaborazioni" ClsId="DA9000" type="9000" scan="3">
      <CHANNEL name="RH" ClsId="DA9000_MEM" id="29" type="0" expr="(M0-(M0-100))*(M0>100)" min="0" max="100" mem_ist="22"/>
      <CHANNEL name="BAR" ClsId="DA9000_MEM" id="23" type="0" expr="1024.5+$12" min="700" max="1100" mem_ist="23"/>
      <CHANNEL name="DIR" ClsId="DA9000_MEM" id="35" type="0" expr="M0*(M0>0)*(M0<360)" min="0" max="359" mem_ist="37"/>
      <CHANNEL name="PPS" ClsId="DA9000_MEM" id="25" type="0" expr="(M0>0.4) AND (M0<0.9))*100" min="0" max="100" mem_ist="26"/>
      <CHANNEL name="RAD" ClsId="DA9000_MEM" id="30" type="0" expr="M0*(M0>0)" min="0" max="2000" mem_ist="38"/>
      <CHANNEL name="REF" ClsId="DA9000_MEM" id="31" type="0" expr="M0*(M0>0)" min="0" max="2000" mem_ist="39"/>
      <CHANNEL name="ALB" ClsId="DA9000_MEM" id="32" type="0" expr="100*(M39/M38)*(M38>0)" min="0" max="100" mem_ist="32"/>
    </SENSOR>
    <SENSOR name="Preelaborazione NIV" ClsId="DA9000" type="9000" scan="3">
      <CHANNEL name="LEV" ClsId="DA9000_MEM" id="70" type="0" expr="1000-M0+$11-400" min="-10" max="1000" mem_ist="27"/>
      <CHANNEL name="NIV" ClsId="DA9000_MEM" id="27" type="0" expr="M0*(M0>0)" min="0" max="1000" mem_ist="28"/>
    </SENSOR>
    <SENSOR name="Cestione radio" ClsId="DA9000" type="9000" scan="1">
      <CHANNEL name="Ora" ClsId="DA9000_HH" id="3" type="2" expr="" min="0" max="23" mem_ist="95"/>
      <CHANNEL name="Minuto" ClsId="DA9000_MM" id="4" type="2" expr="" min="0" max="59" mem_ist="96"/>
      <CHANNEL name="Secondo" ClsId="DA9000_SS" id="5" type="2" expr="" min="0" max="59" mem_ist="97"/>
      <CHANNEL name="Countdown" ClsId="DA9000_MEM" id="99" type="0" expr="M0-(M0>0)/60" min="0" max="14400" mem_ist="99"/>
    </SENSOR>
  </ACQUISITIONS>
  <PROCESSINGS>
    <PROCESSING name="Elaborazione WIND 10'" ClsId="ELAB_WIND" type="2" scan="600" shift="0" min_rate="0" param_inl="-1" mem_inl="0036" mem_o>
    <PROCESSING name="Elaborazione WIND 60'" ClsId="ELAB_WIND" type="2" scan="3600" shift="0" min_rate="0" param_inl="-1" mem_inl="0036" mem_o>
    <PROCESSING name="Elaborazione TA 30'" ClsId="ELAB_STD" type="1" scan="1800" shift="0" id="0" min_rate="0" mem_inl="0021" mem_outl="149">
    <PROCESSING name="Elaborazione RH 30'" ClsId="ELAB_STD" type="1" scan="1800" shift="0" id="0" min_rate="0" mem_inl="0022" mem_outl="162">
    <PROCESSING name="Elaborazione BAR 30'" ClsId="ELAB_STD" type="1" scan="1800" shift="0" id="0" min_rate="0" mem_inl="0023" mem_outl="175">
  </PROCESSINGS>

```

The following paragraphs describe in detail the functions that can be configured in the datalogger.

For the creation and management of configuration by a user, refer to the specific manual **s012-d DAK – Datalogger programming manual DA9000/DA15K/DA18K**.

### 3.5.2 Main cycle and secondary processes

All the priority functions of data acquisition, processing and storage are performed sequentially by the datalogger programme within a main work cycle.

The sequence of execution of the main cycle is composed in the order of the following steps:

- 1st MEASURE ACQUISITION
- 2nd DATA PROCESSING
- 3rd CONTROLS
- 4th DATA STORAGE
- 5th DATA TRANSMISSION

It can be noted how, when writing the configuration file, the functions are inserted in the order described.

Other functions requiring longer execution times or in any case which would be blocking for cycle time purposes, are performed in separate work processes, in particular the data transmission functions and the management of communication devices with the datalogger.

The secondary processes (or work *threads*) can be listed as follows:

- Serial communication thread (*interrupt* on ports COM1, COM4).
- TCP/IP communication thread (incoming TCP/IP connection).
- RAS dial-up connection process.
- TCP/IP tunnel connection and communication process.
- FTP file transfer process.
- HTTP data transmission process.
- IRIDIUM satellite transmission/reception process.
- SMS transmission and reception process.
- TTS (Text to Speech) transmission process.
- Data compression process (ZIP files).
- Date/time synchronisation process (Time Protocol).
- Measurement display process.

### **3.5.3 User parameters**

---

The parameters section allows to create and maintain in the configuration file several alphanumeric parameters that can be set by the user. The values can be changed directly on the datalogger display (see section 3.4.2 *Parameters*).

The parameters can be used in the following cases:

- As a flag to disable the measurement scan or other functions;
- In measurement conversion formulas or in any other data evaluation expression;
- As a measurement offset or alarm threshold;
- As a data processing and/or storage interval;
- To manage telephone numbers, IP addresses, etc.

To use a parameter within the configuration, it is necessary to refer to the identification number preceded by the "\$" symbol, (e.g. \$11, \$12, etc.)

Parameter configuration:

- **id**: numerical identification of the parameter (specified in configuration with the "\$" symbol placed first).
- **name**: parameter name.
- **unit**: unit of measurement.
- **value**: assigned value.

### **3.5.4 Acquisition functions**

---

The measurement acquisition section must be configured by entering the definitions of the sensors and/or acquisition cards to be queried with the relative communication parameters and measurement channels. The raw data obtained from the query is pre-processed for conversion of the value into engineering units and a subsequent plausibility check.

In general, the structure that describes the acquisition of a measuring sensor is formed as follows:

```
SENSOR <Communication parameters>  
  1st CHANNEL <data processing parameters>
```

2° CHANNEL <data processing parameters>

...

Nth CHANNEL <data processing parameters>

## SENSOR

The sensor communication parameters are listed below:

- **name**: name or description of the sensor;
- **type**: type of sensor to acquire (main communication standards in bold):
  0. OLIMPO / DA7000 / SMP datalogger (via !IM commands)
  1. Store&Forward / ISIDL / SISLP intelligent sensor
  2. SIAP 3840 / 3840P sensor
  - 3. SDI-12 standard**
  - 4. MODBUS standard**
  5. Generic serial device (VAISALA, SETRA barometers, etc.)
  6. Siap+Micros wave sensor (via SISR SIAP protocol)
  7. Microcom GTX Satellite Data Transmitter
  8. Campbell Scientific PWS100 visibility meter
  - 9. NMEA standard**
  10. DA7000 datalogger (via!ll commands)
  11. SISLP geophone
  12. STS DL/N probe
  13. SBE-26plus probe
- 3820. SIAP 3820 sensor
- 3830. SIAP 3830 sensor
- 9000. Local acquisition (series DA9000 / DA18K datalogger)
  - **id\_hw**: alphanumeric character that identifies the sensor's hardware address;
  - **scan**: interval in seconds with which all the channels are acquired (in some sensors the scan is subsequently defined per channel);
  - **funct**: for MODBUS sensor/card, specifies the acquisition function;
  - **address**: for MODBUS sensor/card, specifies the initial acquisition address;
  - **registers**: for MODBUS sensor/card, specifies the quantity of data requested;
  - **wait**: time in seconds with which the query command is anticipated (SDI-12 type sensors);
  - **com**: serial port on which the sensor is connected (0 for TCP/IP type sensor);
  - **baud**: specifies the serial communication speed (bps);
  - **databit, parity, stopbit**: opening parameters of the serial port (number of data bits, parity bits, stop bits);
  - **ip**: specifies the IP address of the TCP/IP sensor;
  - **port**: specifies the port on which it is possible to attach the TCP/IP sensor;
  - **timeout**: maximum response waiting time (ms);
  - **delay**: delay/pause after the acquisition (ms);

Note that the acquisition of analogue/digital measurements from the base board of the datalogger (base 9000 and/or BASE15K) will be configured as acquisition of a standard MODBUS type sensor.

The parameters for defining the channel and for data processing are listed below:

- **name**: descriptive name of the measurement channel

- **id**: numerical identification of the channel (for an OLIMPO / DA7000 / SMP type sensor it identifies the location of the internal memory that is acquired via !IM command; for MODBUS sensors it identifies the position of the register to be acquired starting from the initial address; for a Campbell PWS100 visibility sensor it identifies the message field to be acquired).
- **scan**: interval, in seconds, with which the channel is acquired (if not already specified at sensor level).
- **type**: data type (for local acquisition, it specifies the type of internal data: 0 = internal location specified by **id**, 1 = digital input I0÷I3, 2 = date/time variables specifying with *id* 0=year, 1=month, 2=day, 3=time, 4=minute, 5=second; for a Campbell PWS100 visibility sensor it specifies the sensor number or data position).
- **cmd**: specifies any command for a generic serial device (e.g. "SEND" for VAISALA barometric sensor).
- **conv**: pre-conversion expression of the acquired signal (optional).
- **expr**: conversion expression / correction formula to apply to the acquired signal to obtain the measurement value in engineering units.
- **min**: minimum plausibility value below which the measurement is invalidated.
- **max**: maximum plausibility value above which the measurement is invalidated.
- **mem\_ist**: memory location in which the acquired measurement is stored.

### 3.5.5 Processing functions

---

This section deals with the periodic processing of the data acquired. The data processing phase comes immediately after acquisition. Each valid measurement acquired is entered into the processing function as a sample to be processed. The function returns the statistical data at the end of the period set in the memory locations assigned to the output.

The parameters of the processing process are defined below:

- **name**: processing name or description;
- **type**: processing type:
  1. Standard processing.
  2. Wind processing.
  3. Pulled processing.
  4. Daily evapotranspiration calculation (ETo).
  5. accumulated rainfall processing
  6. Wave measure processing.
  7. Wind direction processing (ICAO regulations).
  8. Wind speed processing (ICAO regulations).
  9. Tsunami warning forecast.
- **scan**: data processing / observation interval (seconds);
- **shift**: interval shift to delay or anticipate the processing deadline (seconds);
- **min\_rate**: minimum rate of valid data requested;
- **param\_in1...param\_inN**: set of user parameters or input constants.
- **mem\_in1...mem\_inN**: set of input data memory locations to be provided.
- **mem\_out1...mem\_outN**: set of resulting output data memory locations.

The following pages show for each type of processing the allocation tables of the data to be provided at input and the resulting statistical output data.

### STANDARD PROCESSING

<i>Parameter</i>	<i>Description</i>
<b>mem_in1</b>	Instantaneous measurement
<b>mem_out1</b>	Sum
<b>mem_out2</b>	Counter
<b>mem_out3</b>	Valid data counter
<b>mem_out4</b>	Average
<b>mem_out5</b>	Minimum
<b>mem_out6</b>	Minimum minute
<b>mem_out7</b>	Maximum
<b>mem_out8</b>	Maximum minute
<b>mem_out9</b>	% of valid data
<b>mem_out10</b>	Variance
<b>mem_out11</b>	Standard deviation
<b>mem_out12</b>	Measurement reference (value of the last measurement sample)
<b>mem_out13</b>	Measurement deviation (deviation of measurement from last sample)

### PULLED PROCESSING

<i>Parameter</i>	<i>Description</i>
<b>mem_in1</b>	Instantaneous measurement
<b>mem_out1</b>	Counter
<b>mem_out2</b>	Valid data counter
<b>mem_out3</b>	% of valid data
<b>mem_out4</b>	Moving accumulated
<b>mem_out5</b>	Moving average
<b>mem_out6</b>	Moving drift
<b>mem_out7</b>	Moving minimum
<b>mem_out8</b>	Moving maximum

### WIND PROCESSING

<i>Parameter</i>	<i>Description</i>
<b>mem_in1</b>	Instantaneous wind speed measurement
<b>mem_in2</b>	Instantaneous wind direction measurement
<b>param_in1</b>	Direction invalidation speed threshold (typical value: 0.5 m/s)
<b>mem_out1</b>	Instantaneous direction
<b>mem_out2</b>	Direction SIN sum
<b>mem_out3</b>	Direction COS sum
<b>mem_out4</b>	Valid direction data counter
<b>mem_out5</b>	Calm sector counter
<b>mem_out6</b>	Direction for maximum speed

<b>mem_out7</b>	Maximum speed
<b>mem_out8</b>	Maximum speed measure counter
<b>mem_out9</b>	Valid data speed counter
<b>mem_out10</b>	Speed sum
<b>mem_out11</b>	Vectorial direction SIN sum
<b>mem_out12</b>	Vectorial speed COS sum
<b>mem_out13</b>	Time base counter
<b>mem_out14</b>	Valid direction and speed data counter
<b>mem_out15</b>	VALID DIRECTION DATA COUNTER (*)
<b>mem_out16</b>	AVERAGE DIRECTION (*)
<b>mem_out17</b>	VALID SPEED DATA COUNTER (*)
<b>mem_out18</b>	AVERAGE SPEED (*)
<b>mem_out19</b>	VECTORIAL WIND SPEED (*)
<b>mem_out20</b>	VECTORIAL WIND DIRECTION (*)
<b>mem_out21</b>	DIRECTION FOR MAXIMUM WIND SPEED (*)
<b>mem_out22</b>	MAXIMUM WIND SPEED (*)
<b>mem_out23</b>	SPEED STANDARD DEVIATION (*)
<b>mem_out24</b>	DIRECTION STANDARD DEVIATION (*)

(\*) Values available only at end of processing period

#### **WIND DIRECTION PROCESSING (ICAO regulations)**

The processing provides the output of the moving average and wind direction (start and end) data calculated in the set observation interval (typically 2 or 10 minutes). The values are expressed in degrees north (°N). If the instantaneous speed intensity does not exceed the set validation threshold (typically 3KT or 1.54 m/s), the samples of the acquired direction will not be taken into account for the calculation. In this case, the output data will be invalidated at the end of the interval. Furthermore, the flagging can be invalidated if the variation is less than 60° or greater than 180°.

<i>Parameter</i>	<i>Description</i>
<b>mem_in1</b>	Instantaneous wind direction measurement (°N)
<b>mem_in2</b>	Instantaneous wind speed measurement (KT or m/s)
<b>param_in1</b>	Validation speed threshold (typical value: 3KT or 1.54 m/s)
<b>mem_out1</b>	Total counter
<b>mem_out2</b>	Valid data counter
<b>mem_out3</b>	Moving accumulated
<b>mem_out4</b>	MOVING AVERAGE (DIR)
<b>mem_out5</b>	START OF FLAGGING (BTN)
<b>mem_out6</b>	END OF FLAGGING (AND)

#### **WIND SPEED PROCESSING (ICAO regulations)**

The processing provides the output of the moving average and wind speed gust data calculated in the set observation interval (typically 2 or 10 minutes). The values can be expressed in knots (KT) or m/s. The gust value is valid when the maximum sample of the acquired speed is above the moving average plus the set threshold parameter (3KT or 5.14 m/s). In other cases, the gust will be invalidated at the end.

<i>Parameter</i>	<i>Description</i>
<b>mem_in1</b>	Instantaneous wind speed measurement (KT or m/s)
<b>param_in1</b>	Average speed limit threshold (typical value: 10KT or 5.14 m/s)
<b>mem_out1</b>	Total counter
<b>mem_out2</b>	Valid data counter
<b>mem_out3</b>	Moving accumulated
<b>mem_out4</b>	MOVING AVERAGE (SPEED)
<b>mem_out5</b>	GUST

### **WAVE MEASURE PROCESSING**

<i>Parameter</i>	<i>Description</i>
<b>mem_in1</b>	Instantaneous level measurement [m]
<b>param_in1</b>	Frequency of level measurements [Hz] (typical value: 4 Hz = 4 samples/second)
<b>param_in2</b>	Marine depth [m] (typical value: 10 m)
<b>param_in3</b>	File for storing level measurements acquired at input.
<b>param_in4</b>	File for storing output processing report.
<b>param_in5</b>	File for storing output wave summary report.
<i>Signal stability</i>	
<b>mem_out1</b>	a = intercept level/time
<b>mem_out2</b>	b = slope trend level/time
<i>Level statistics</i>	
<b>mem_out3</b>	number of measurements
<b>mem_out4</b>	average value (m)
<b>mem_out5</b>	minimum value (m)
<b>mem_out6</b>	maximum value (m)
<b>mem_out7</b>	RMS value (m)
<b>mem_out8</b>	standard deviation (m)
<b>mem_out9</b>	kurtosis
<b>mem_out10</b>	asymmetry
<i>Wave height statistics</i>	
<b>mem_out11</b>	number of waves
<b>mem_out12</b>	average value (m)
<b>mem_out13</b>	minimum value (m)
<b>mem_out14</b>	maximum value (m)

<b>mem_out15</b>	RMS value (m)
<b>mem_out16</b>	significant height (m)
<b>mem_out17</b>	1/10 height (m)
<b>mem_out18</b>	standard deviation (m)
<b>mem_out19</b>	kurtosis
<b>mem_out20</b>	asymmetry
<b>mem_out21</b>	correlation between successive heights
<i>Zero up-crossing period statistics</i>	
<b>mem_out22</b>	average value (s)
<b>mem_out23</b>	minimum value (s)
<b>mem_out24</b>	maximum value (s)
<b>mem_out25</b>	RMS value (s)
<b>mem_out26</b>	significant period (s)
<b>mem_out27</b>	1/10 period (s)
<b>mem_out28</b>	average period between crests (s)
<b>mem_out29</b>	standard deviation (s)
<b>mem_out30</b>	kurtosis
<b>mem_out31</b>	asymmetry

**DAILY EVAPOTRANSPIRATION CALCULATION (ET<sub>o</sub>)**

<i>Parameter</i>	<i>Description</i>
<b>param_in1</b>	Calculation mode (1 = with net solar radiation, 2 = with total solar radiation)
<b>param_in2</b>	Height above sea level (MASL)
<b>param_in3</b>	Latitude °N
<b>param_in4</b>	File for storing output processing report.
<b>param_in5</b>	File for storing output wave summary report.
<b>mem_in1</b>	Daily average temperature (°C)
<b>mem_in2</b>	Minimum daily temperature (°C)
<b>mem_in3</b>	Maximum daily temperature (°C)
<b>mem_in4</b>	Minimum daily humidity (%)
<b>mem_in5</b>	Maximum daily humidity (%)

<b>mem_in6</b>	Average daily wind speed at 2 metres (m/s)
<b>mem_in7</b>	Cumulative daily solar radiation in MJ/m2
<b>mem_out1</b>	Daily evapotranspiration result (ETo) (mm)

### ACCUMULATED PLUVIOMETRIC PROCESSING

<i>Parameter</i>	<i>Description</i>
<b>mem_in1</b>	Acquired rainfall measurement (mm)
<b>mem_out1</b>	Total counter
<b>mem_out2</b>	Valid data counter
<b>mem_out3</b>	Instant rain calculated in the cycle (mm)
<b>mem_out4</b>	Not visible (reserved)
<b>mem_out5</b>	Not visible (reserved)
<b>mem_out6</b>	Not visible (reserved)
<b>mem_out7</b>	Not visible (reserved)
<b>mem_out8</b>	Accumulated rain in the range (mm)
<b>mem_out9</b>	Samples valid in the range (%)
<b>mem_out10</b>	Total accumulated precipitation (mm)
<b>mem_out11</b>	Precipitation accumulated in maintenance/rain gauge test (mm)

### 3.5.6 Control functions

This section is dedicated to the management of alarms on the measures acquired and the control of digital and/or analogue outputs to external MODBUS devices. The user can define the minimum and/or maximum threshold value for a single data and insert the actions to be taken if the measurement goes into alarm state (change of storage frequency, sending of SMS messages, activation of output contacts, etc.).

The control functions are subdivided into the following types: ALARM, • CONTROL, • OUTPUT.

Definition of the ALARM function:

- **name**: alarm name or description;
- **type**: alarm type:
  0. MEASUREMENT ALARM
  1. FILE ALARM
- **scan**: interval, in seconds, with which the alarm control is performed;
- **mem\_in**: memory location of the measurement to control;
- **min**: minimum alarm threshold; (\*)
- **pre\_min**: minimum pre-alarm threshold; (\*)
- **pre\_max**: maximum pre-alarm threshold; (\*)
- **max**: maximum alarm threshold; (\*)
- **reentry**: return offset (threshold hysteresis);
- **wait**: dwell time before entering alarm state (seconds);
- **cad**: determines the change of processing and storage rate (0=No, 1=Yes);

- **path\_file**: specifies the path and name of the file to control (only for file alarm);
- **watch\_dog**: specifies the intervention of the external watchdog in case of alarm (only for file alarm);
- **mem\_all**: memory location in which the alarm state is recorded.

Alarm state code table:

- 2. MINIMUM ALARM
- 1. MINIMUM PRE-ALARM
- 0. NORMAL
- 1. MAXIMUM PRE-ALARM
- 2. MAXIMUM ALARM
- 3. ACQUISITION ERROR
- 4. MEASUREMENT OUT OF RANGE

The alarm control on the measurement is performed periodically according to the set interval. If the measurement value exceeds (or falls below) the relative maximum (or minimum) threshold after a specified dwell time, the corresponding alarm will be generated. The alarm code is stored in the assigned location. In addition, it is possible to control the rate change of all processing and storage containing the same parameterised interval (see “*Rate change*” control function).

The file alarm control checks if the specified file is not modified (if the file does not change date/time) and after the dwell time will generate an error alarm (alarm code 3). In case of file alarm, the user can programme the restart of the datalogger by specifying the watchdog intervention.

Definition of the CONTROL function:

- **name**: control name or description;
- **type**: control type:
  - 2. RATE CHANGE
  - 3. DATALOGGER RESET
  - 4. DATE/TIME SETTING
  - 5. BACKUP DATA COMPRESSION
- **scan**: interval in seconds in which the control is performed;
- **expr**: Boolean expression to evaluate (if the evaluation is true, the data logger will be restarted);
- **cadn, cadp, cada**: rates in normal, pre-alarm and alarm state; (\*)
- **mode**: mode for immediate storage at rate change (0=No, 1=Yes); (\*)
- **timezone, mem\_date, mem\_time**: time zone and memory locations for setting date/time;
- **mem\_all**: memory location of rate status:
  - 0. Normal rate
  - 1. Pre-alarm rate
  - 2. Alarm rate

(\*) “*Rate change*” function

The rate change function intervenes by dynamically substituting the intervals that have been parameterised in the data processing and storage functions. For substitution to take place correctly, it is necessary to specify the intervals concerned and the rates using variable parameters (e.g. \$11, \$12, \$13).

Definition of OUTPUT function:

- **name**: command name or description;

- **type:** output type to activate:
  0. DIGITAL OUTPUT
  1. ANALOGUE OUTPUT
- **scan:** interval in seconds in which the output control is performed;
- **id\_hw:** numeric which identifies the address of the device to be controlled (omit or set 0 to command the local digital outputs O0..O3 of the datalogger);
- **com:** serial port on which the device is connected (set 0 for MODBUS TCP/IP);
- **baud:** specifies the serial communication speed (bps);
- **databit, parity, stopbit:** opening parameters of the serial port (number of data bits, parity bits, stop bits);
- **ip:** specifies the IP address of the device (MODBUS TCP/IP);
- **port:** specifies the port on which it is possible to attach the device (MODBUS TCP/IP);
- **mem\_in:** memory location of the input value (only for analogue output);
- **expr:** expression to be evaluated (for digital outputs, if the evaluation is different from zero, the output will be activated, otherwise it will be deactivated; for analogue outputs, it is the expression to be applied for conversion of the input value);
- **logic:** control logic only for digital outputs; if different from zero, the expression result is inverted (reverse logic);
- **channel:** channel to be controlled (free setting for generic MODBUS device):
  - 0 ÷ 3 for O0 ÷ O3 local digital outputs (datalogger)
  - 1 ÷ 8 for OD1 ÷ OD8 digital outputs, 9000 base card and BASE15K card
  - 0 for Powered Output (only BASE15K card)
  - 50, 51 for OA1 ÷ OA2 analogue outputs, 9000 base card
  - 01, 03 for OA1 ÷ OA2 analogue outputs, BASE15K base card

Note:

The protocol used for control of the outputs is always **MODBUS RTU** or **MODBUS TCP/IP**. Specifically:

- Function 15 (Write Multiple Coils) for digital output writing
- Function 16 (Write Multiple Registers) for analogue output writing

### **3.5.7 Data storage**

---

Data logging is performed depending on the configuration set on separate memory areas. The memory areas, called archive files, can contain different types of record reports (instantaneous measurements, statistical data, alarms, etc.) and are managed by the datalogger in a circular manner. Once the maximum available space is occupied, storage continues by overwriting the older recordings.

The default storage medium is the device's internal flash memory. The data archive folder is located at the default path \NandFlash\DA9000\Archivio. Inside the folder, each archive file is named in:

**n.dat** (where: *n* = file number).

The configuration of the support parameters of a record is described here:

- **name:** record name or description;
- **id:** numerical storage identification (optional) alternative to general storage identification;
- **format:** record format:
  0. **SIAP+MICROS standard**, dynamic record format
  1. Pseudo-binary positional format <sup>(1)</sup>
  2. SMS data record format <sup>(\*)</sup>

3. Generic CSV format (from serial reception)
  4. XML format for MeteoCTX
- **type:** record report type:
    0. HISTORICAL records
    1. INSTANTANEOUS records
    2. ALARM records <sup>(2)</sup>
    9. Generic CSV record (from serial reception)
    10. GEOSIS geophone event
  - **scan:** interval in seconds in which the record is recorded;
  - **shift:** interval shift to delay or anticipate the storage deadline (seconds);
  - **file:** archive file number (e.g.: specifying 1 will create the data file "1.dat").
  - **merge:** option to merge records with the same timetable;
  - **backup:** enables/disables the backup of the specific record;
  - **view:** enables/disables data display (Data report);

<sup>(1)</sup> Sequential recording of values coded in Pseudo-Binary 3 byte (18-bit) format.

<sup>(2)</sup> Alarm recording is performed for events not yet recorded at the end of the storage scan.

<sup>(\*)</sup> Obsolete format.

The data writing parameters are as below:

- **name:** data name;
- **id:** measurement identification;
- **type:** data attribute (identification letter of type: "A" = instantaneous, "B"= average, etc.);
- **dec:** number of decimals with which the value is formatted;
- **mem:** data memory location;
- **unit:** data unit of measurement;
- **hide:** hides the data in the display (Data report);

The internal logging autonomy may vary because it is determined by the configuration in the datalogger. With free flash memory space of about 215MB and a data record every 10 minutes, an average autonomy of 7000 days, or 19 years, is reached.

### Retention of data in memory (RAM) function

The function performs a periodic retention copy of the last archived data in RAM memory. This function is useful for reducing response times to a '*Last Record*' request command.

Definition of parameters for data retention function in RAM memory:

- **name:** name or description;
- **format:** record format:
  0. SIAP+MICROS standard dynamic record format
- **scan:** interval in seconds in which retention is performed;
- **shift:** interval shift to delay or anticipate storage (seconds);
- **file:** archive file number;

### **3.5.8 Data backup**

---

The recordings made in the archive files can also be enabled for automatic copying to external media (data backup copy). In this case, the storage medium will be managed in a linear way, i.e. there will be progressive filling until the available space is saturated.

The primary unit for data backup is the removable **SD Card** type memory, default path: \SD Memory Card on Slot A\BackUp\Data. In the backup folder each data archive is copied into progressive daily files named in:

**FILE $n$ \_YYYYMMDD.dat**

where:  $n$  = archive file number, YYYY = year, MM = month, DD = day.

Example backup file list:

FILE6\_20170901.dat  
FILE6\_20170902.dat  
FILE6\_20170903.dat  
FILE6\_20170904.dat

In addition to the SD Card, a secondary drive can be inserted on a USB flash medium (USB pen drive). IN this case, the path of the backup folder will be: Hard Disk\BackUp\Data.

The user can also create a circular series of daily data backups in the internal archive folder (path: \NandFlash\DA9000\Archivio\Backup) useful for downloading from the web page. The maximum number of files that can be retained is typically 30 days of data.

The machine log files are also kept in the primary SD Card backup drive in the folder: \SD Memory Card on Slot A\BackUp\Logs.

#### **Replacement of SD Card memory**

The SD memory card can be removed at any time, even with the programme running. To avoid any record cutoff during recording, it is recommended to close the programme or switch off the datalogger during replacement.

### **3.5.9 Transmission functions**

---

The DA18K datalogger can be configured to send archive data and/or measurement alarms in various communication modes.

The main transmission functions are:

- Direct serial transmission of data or alarms in text and/or record format;
- Transmission of SMS messages of data or alarms in text and/or record format;
- File transmission via FTP(S) / SFTP protocol (archive data, alarm recording, webcam images, etc.);
- Data transmission via HTTP protocol;
- e-mail transmission with SSL/TLS protocol (attached data/files, alarm notifications, report measures, etc.);
- Data or alarm transmission via satellite radio (GOES, METEOSAT, IRIDIUM);
- TTS speech synthesis message transmission;

- Date transmission via TCP/IP tunnel;

Parameter configuration for direct transmission and SMS messages:

- **name:** transmission name;
- **type:** type of data to transmit:
  1. HISTORICAL
  2. INSTANTANEOUS
  3. ALARMS <sup>(1)</sup>
- **format:** transmitted data format:
  0. FORMATTED TEXT
    1. STANDARD RECORD REPORT
    2. GENERIC DATA FILE RECORD
- **scan:** interval or send scan (seconds);
- **shift:** interval shift to delay or anticipate (seconds);
- **com:** serial port on which to make the transmission;
- **baud:** specifies the serial communication speed (bps);
- **dtr:** DTR criterion setting: 0=Disable, 1=Enable, 2=Handshake (Default: 0=Disable)
- **rts:** RTS criterion setting: 0=Disable, 1=Enable, 2=Handshake, 3=Toggle (Default: 3=Toggle)
- **string:** constant string to send (for simple transmission only);
- **phone:** telephone number(s) of SMS recipient(s). Separate with “;” if there is more than one number;
- **attempts:** attempts to send SMS message;

Specify data sending parameters:

- **name:** data name;
- **id:** measurement identification (only for record report);
- **type:** data attribute (identification letter of type: “A” = instantaneous, “B”= average, etc.);
- **text:** descriptive text of data (only for formatted text);
- **unit:** data unit of measurement (only for formatted text);
- **dec:** number of decimals with which the value is formatted;
- **mem:** data memory location;

<sup>(1)</sup> Alarm transmission is performed for events not yet recorded at the end of the send scan.

### Description of FTP transmission

The function uses a secondary process for FTP transfer by taking files from a common local source folder. The data file to be sent is prepared in a local folder, taking from the archive the data not yet transmitted and assigning the file the name already formatted for the destination. Each file will have a default maximum size (*pack*) to speed up and ensure the transfer process.

The data file is prepared according to the programmed scan interval. Any data recovery after a communication interruption will be managed with more frequent scans (up to 5 minutes).

To transfer image files or other file types, it is necessary to specify the path of the source file to be sent. The function will then perform a move with rename to the local folder.

To further reduce the size of the files to be sent, it is possible to perform a ZIP compression (this must, however, be in accordance with the decompression to be performed on the server).

The local files are automatically deleted only after transfer confirmation.

Definition of FTP transmission parameters:

- **name:** transmission name;
- **type:** protocol 0=FTP (default), 1=SFTP (SSH File Transfer Protocol);
- **path:** path of the local source folder of the files to be sent (default: `WandFlash\DA9000\Ftp`). Note: for further FTP transmissions (e.g. on a second server or on a different directory), it is necessary to specify a different local input folder (e.g. `WandFlash\DA9000\Ftp2`);
- **host:** server IP address;
- **port:** server TCP port (default: 21);
- **user:** user name/account;
- **password:** access password;
- **mode:** data encryption: 0=None, 1=SSL/TLS if available, 2=SSL/TLS explicit, 3=SSL implicit;
- **dir:** remote directory of destination files;

Parameters of the file to send:

- **scan:** interval (in seconds) with which the data copy of the file to be sent is prepared;
- **file:** path of the source file to be copied or archive number from which to extract the data;
- **pack:** maximum size of the data packet to be sent (default 128KB);
- **zip:** ZIP compression of the file before sending (default: 0=No);
- **format:** record transformation format:
  0. SIAP+MICROS standard record format
  1. OpenCSV record format
  3. SIRT CSV record format
  4. MeteoCTX XML record format
  5. DMV XML record format
  6. SIRAV XML record format
- **rename:** name of remote destination file. The name can be formatted with the following special characters:
  - %iii                    station storage ID
  - %yyyy%mm%dd        Year, month and day of transmission
  - %hh%nn%ss            Hours, minutes and seconds of transmission

Definition of GOES / METEOSAT satellite transmission parameters:

- **scan:** interval (in seconds) in which the transmission is performed;
- **type:** transmission type: 0=*Timed Transmit Buffer* (default), 1=*Random Transmit Buffer*
- **com:** serial port on which the transmitter is connected;
- **baud:** setting of the serial port speed (default: 9600 b/s)

- **header:** head string (optional)
- **file:** archive number from which to collect data (e.g. file 7 containing the data saved in Pseudo-Binary format).

### 3.5.10 Display

---

In this section, the user defines the rows of the measurements page shown on the display (section 3.4.1 *Measures*). The display order corresponds to the order in which the elements are inserted in the section. The scan (interval) with which the display is updated is by default 3 seconds.

Definition of the display row:

- **text:** name/description;
- **unit:** unit of measurement.
- **dec:** number of decimals for formatting the value.
- **mem:** data/measurement memory location.
- **mem\_all:** (optional) memory location of the alarm status (even if omitted, the alarm status is automatically displayed if an alarm relating to the measurement is present).

### 3.5.11 Basic code

---

The user can enter the Basic code execution in the configuration, through which the memory locations used in the process can be recalled and manipulated.

For instructions on use of the Basic code and relating functions, refer to the specific manual **s012-d DAK – Dataloggers programming manual DA9000/DA15K/DA18K**.

### 3.5.12 Variables and operators

---

The following tables list the variables and function operators that can be used in the expressions.

#### Variables in memory

<b>M<sub>i</sub></b>	Value of the measurement stored in location <i>i</i> (e.g. M001 = location value 001) If the measurement assumes the value = -9999, it indicates an invalid value. Note: M0 = raw value of the measurement just acquired by the channel.
<b>V<sub>i</sub></b>	Validation code of measurement location <i>i</i> (e.g. V001 = validation code of the measurement M001). If the validation code assumes the value = 1, it indicates that the measurement is valid. Instead, if it assumes the value = 0, it indicates that the measurement is invalid.
<b>\$<sub>n</sub></b>	Value of the parameter with <i>n</i> identifier (e.g. \$11 = parameter value ID 11)

#### Arithmetic operators

<b>+</b>	Addition
<b>-</b>	Subtraction
<b>/</b>	Division
<b>*</b>	Multiplication
<b>^</b>	Exponentiation
<b>MOD</b>	Division remainder

### Logical operators

<b>NOT</b>	Logical negation ( equivalent operator: ! )
<b>AND</b>	Logical conjunction
<b>OR</b>	Logical disjunction

### Comparison operators

<b>=</b>	Equal
<b>&gt;</b>	Greater than
<b>&lt;</b>	Less than
<b>?</b>	Different

### Bit comparison operators

<b>&amp;</b>	Bitwise AND
<b> </b>	Bitwise inclusive OR

### Boolean constants

<b>FALSE</b>	Equivalent to value <b>0</b>
<b>TRUE</b>	Equivalent to value <b>1</b>

### Mathematical functions

<b>ABS</b>	Absolute value of a number
<b>ATN</b>	Arctangent of a number
<b>COS</b>	Cosine of an angle
<b>EXP</b>	Natural logarithms base e exponentiation
<b>INT</b>	Integer part of a number
<b>LIM</b>	Maximum or minimum value of a number between two limits
<b>LN</b>	Natural logarithm of a number
<b>LOG</b>	Logarithm in base 10 of a number
<b>MAX</b>	Maximum value between two numbers
<b>MIN</b>	Minimum value between two numbers
<b>SGN</b>	Sign of a number
<b>SIN</b>	Sine of an angle
<b>SQR</b>	Square root of a number
<b>TAN</b>	Tangent of an angle

## 3.6 Data record report

The data stored in the archive files of the DA18K control unit are formatted according to the SIAP+MICROS standard called **Dynamic Record Report**.

The Dynamic Record Report contains all information about the datalogger station (station storage ID), the date and time of data storage and the type of data stored.

Storage date and time constitute the time stamp of the record which is always referred to the end of the processing period.

In the record reports with *dynamic structure*, the length of the report varies according to the number and type of data contained. Therefore, in situations where the data to be included in the report is minimal, the length of the report, and consequently also the space occupied by the data, will be very limited.

The dynamic report is adapted to contain the instantaneous data continuously acquired by the datalogger, the statistical data obtained by the programmed processing functions, and the alarm data generated by the control unit according to the events.

The report consists of three distinct parts named respectively:

<b>HEAD</b>	<b>BODY</b>	<b>TERMINATOR</b>
-------------	-------------	-------------------

Each of these parts is subdivided internally into fields separated by the character “,” (ASCII 44). All data (*Instantaneous Data, Statistical Data, Alarm Data, etc.*) managed by the system is saved in the internal memory (flash) of the control unit and, if present, in the external memory (SD memory card).

Depending on the type of data, the recording is made in separate areas of the memory. As described below, the subdivision into areas is dictated by precise archiving needs.

The is stored in the corresponding memory area and written as sequences of recognisable ASCII characters. The storage modes depend on the specific type of the *data* in question. These modes are described by the *Record Reports* that define the structure. Four different archiving modes have been implemented, one for each *data* type.

The report types are:

- **Statistical Data Record Report**
- **Instantaneous Data Record Report**
- **Alarm Data Record Report**
- **Calibration Data Record Report**

For a detailed description of the Siap+Micros record reports, refer to the manual **s011-d Dynamic Records**.

## **3.7 Command interpretations**

---

### **3.7.1 Reception protocols**

---

As described in the initialisation file, the DA18K datalogger can be set to respond to several communication protocols and interpret a set of specific commands.

The supported communication protocols in input are:

1. **Store & Forward** (CRC MOD16)
2. **Modbus RTU / TCP/IP**
3. **TETRA SDS**

The following paragraphs show the syntax of the commands that can be interpreted by the datalogger (*Siap+Micros Store & Forward* commands set). If the commands are not sent correctly, the datalogger will reply with: ?<**command name**> (for unrecognised command) or **-1** (for incorrect parameters).

### 3.7.2 General commands

---

**IDSTAZ** Read and setting commands of the station identification *<id>*:

Read command:       **R IDSTAZ**  
 Reply:                IDSTAZ *<id>*  
 Write command(\*):   **W IDSTAZ=<id>**  
 Reply:                IDSTAZ *<id>*

**ID\_MEM** Read and setting commands of the storage identification *<im>*:

Read command:       **R ID\_MEM**  
 Reply:                ID\_MEM *<im>*  
 Write command(\*):   **W ID\_MEM=<im>**  
 Reply:                ID\_MEM *<im>*

(\* Note: The datalogger must be reset or restarted in order for the identification setting commands to take effect.

**CLK** Clock reading and setting commands. Specify the current date and time in writing; the command will synchronise the system clock and RTC:

Read command:       **CLK**  
 Reply:                *<hh> <nn> <ss> <dd> <mm> <yyyy>*  
 Write command:      **CLK <hh> <nn> <ss> <dd> <mm> <yy[yy]>**  
 Reply:                *<hh> <nn> <ss> <dd> <mm> <yyyy>*

**!FW** Reading of datalogger programme version (*firmware version*):

Read command:       **!FW**  
 Reply:                DA9000/DA18K vers. *<x>.<y>.<z>*

**RESET MICROS** Datalogger reset command (software reboot):

Command:       **RESET MICROS**  
 Reply:        RESET MICROS

**!TW** Watchdog termination command (hardware reboot of data logger):

Command:       **!TW**  
 Reply:        Terminating Watchdog

### 3.7.3 Variable management

---

**!IM** Read and write commands for measurement locations. The read command requires the values of *<n>* locations starting from the start address *<index>*. The write command sets the values of *<n>* locations, specifying position and value for each one:

Read command:       **!IM <n> <index>**  
 Reply:                *<val 1> <val 2> ... <val n>*  
 Write command:      **!WA <n> <pos 1> <val 1> <pos 2> <val 2> ... <pos n> <val n>**  
 Reply:                *no reply*

**!RP** Read and write commands of a user parameter (parameter identification: *<id>*):

Read command:     **!RP <id>**  
Reply:            <value>  
Write command:    **!WP <id> <value>**  
Reply:            <value>

### **3.7.4 Data archive management**

---

**R\_FILE** Shows read size in KB of an archive file <n>:

Command:     **R\_FILE<n>**  
Reply:     \_FILE<n> <size>

**!FR** Requests amount of free storage space in an archive <file>:

Command:     **!FR <file>**  
Reply:     <bytes free>

**!MR** Requests data to be read from an archive <file>:

Command:     **!MR <file>**  
Reply:     <bytes to read>

**!RD** Reads / downloads data from an archive file (*Read Data*). Specify in the order: file number <file>, user number <user> = 1, number of 200-byte data packets <pack>. The command temporarily moves the read pointer:

Command:     **!RD <file> <user> <pack>**  
Reply:     <data records>

**!RS** Gives reading confirmation of an archive file (*Read Set*). The command executes the definitive alignment of the read pointer with the temporary pointer. Specify file number <file> and user number <user> = 1:

Command:     **!RS <file> <user>**  
Reply:     no reply

**!RE** Restores the reading of an archive file (*Restore file*). The command returns the read pointer immediately after the write pointer so you can read the entire file again. Specify file number <file> and user number <user> = 1:

Command:     **!RE <file> <user>**  
Reply:     no reply

**!SC** Deletes an archive file (*Scratch file*). The command clears the read and write pointers so that the file can be rewritten from the start:

Command:     **!SC <file>**  
Reply:     no reply

**!PR** Positions read data of an archive file at the specified date and time. Specify the year, month, day, hour, minute and second of the record in which to place the read pointer. The reply will contain the number of bytes to be read:

Command: **!PR <file> <yyyy> <mm> <dd> <hh> <nn> <ss>**  
 Reply: *<bytes to read>*

**!WR** File writing<sup>(\*)</sup>. The command executes the writing to a data archive file (file no.1 ÷ 253) or on a file predetermined by the system: 0 = Configuration file (CNF.xml), 254 = Initialisation file (INI.xml), 255 = Datalogger programme (DA9000.exe):

Command: **!WR <file> <data to write>**  
 Reply: *no reply*

<sup>(\*)</sup>Note: This command is obsolete. Use the command **!WRB** instead.

**!WRB** File writing with binary pointer. The command executes the writing to a data archive file (file no.1 ÷ 253) or on a file predetermined by the system. Normally used to write the following system files: 0 = Configuration file (CNF.xml), 254 = Initialisation file (INI.xml), 255 = Datalogger programme (DA9000.exe):

Command: **!WRB <file> <pointer> <data to write>**  
 Reply: *no reply*

### **Request latest data**

Command Type:  
 Answer:

<b>!LTR</b> ( <i>Last Text Records</i> ) <i>Dynamic Path (ASCII)</i>	<i>Standard</i>
<b>!LBR</b> ( <i>Last Binary Records</i> ) <i>Track</i>	<i>Standard Binary</i>
<b>!LKR</b> ( <i>Last Kompressed Binary Records</i> )	<i>Compressed Binary Track</i>
<b>!LXR</b> ( <i>Last eXtra Binary Records</i> ) <i>with diagnostics</i>	<i>Compressed binary track</i>

These commands return data from the last registration or recordings that occurred in a preconfigured reference period (maintenance interval).

For example, with a preconfigured hold interval of 30 minutes, sending a request in the 08:30=08:59 time slot, the response received will contain records from 8:01 a.m. to 8:30 a.m. inclusive. Sending the same request after 09:00, you will receive the records from 08.31 to 09.00 inclusive. If the retention period is not configured, the response will contain only the last recorded record.

In the request message you must specify the archive from which you want to read the data (files).

Syntax:

Message	<b>!LTR   !LBR   !LKR   !LXR file [yyyy mm dd hh nn ss]</b>
Answer	<i>&lt;Data Tracking&gt;</i> <sup>(1)</sup>

Commands can additionally synchronize the data-logger clock if date and time settings are specified. The optional parameters are therefore: yyyy (year), mm (month), dd (day), hh (hour), nn (minutes) and ss (seconds).

Note: The clock will only be synchronized if the current setting of the data-logger differs between  $\pm 3$  sec. and  $\pm 50$  min.

1) The format of the data path received in response depends on the type of command sent.

### **Historical data request**

Command Type:

Response:

**!DTR** (*Data Text Records*)  
(ASCII)

*Dynamic Records standard*

**!DBR** (*Data Binary Records*)

*Binary Records standard*

**!DKR** (*Data Kompressed Binary Records*)

*Compressed binary path*

**!DXR** (*Data eXtra Binary Records*)  
*diagnostic*

*Compressed binary Records With diagnostic*

These commands can be used to request/retrieve data records recorded in a specific historical range. If any, all previous records will be sent to the requested instant within the preconfigured reporting period (including the record specified in the request).

For example, with a hold interval set to 30 minutes, data will be returned up to 30 minutes backwards. To retrieve the data from 00.31 to 01.00 it will be necessary to send the request specifying the hours 01:00:00. If the retention period is not configured, the response will contain only the required record.

In the request message it is therefore necessary to specify in addition to the archive from which you want to read the data (file), also the date and time of the recording: yyyy (year), mm (month), dd (day), hh (hour), nn (minutes) and ss (seconds).

Syntax:

Message	<b>!DTR   !DBR   !DKR   !DXR</b> <i>file yyyy mm dd hh nn ss</i>
Response	<i>&lt;data record&gt;</i> <sup>(1)</sup>

<sup>(1)</sup> the format of the data received in response depends on the type of command sent.

### 3.7.5 Output commands

---

**!CO** Command to activate the O0 ÷ O3 local digital outputs of the datalogger:

Command: **!CO <n> <act 1> <out 1> <act 2> <out 2> ... <act n> <out n>**  
 Reply: *no reply*

Activation values <act>:

- 1: ON
- 2: OFF
- 3: PULSE (ON/OFF)
- 4: PULSE (OFF/ON)

Outputs <out>: 0 ÷ 3

Example: **!CO 1 1 0** // Output O0 set to ON

**!WSC** Command for writing a single digital output on a MODBUS device (*Write Single Coil*). Specify the communication port <port> of the datalogger on which the device to be controlled is connected (e.g. for a BASE15K analogue base card, set: 2 = COM2), specify <id> the hardware of the MODBUS device (*Slave*), the address <addr> of the output and value <val> to be set (byte: 0 / 1):

Command: **!WSC <port> <id> <addr> <val>**  
 Reply: *no reply*

**!WMC** Command for the multiple writing of digital outputs on a MODBUS device (*Write Multiple Coils*). Specify the communication port <port> of the datalogger on which the device to be controlled is connected (e.g. for a BASE15K analogue base card, set: 2 = COM2), specify <id> the hardware of the MODBUS device (*Slave*), the data start address <start>, the number <n> of outputs to be controlled and the values <val> to be set (byte: 0..255):

Command: **!WMC <port> <id> <start> <n> <val 1> <val 2> ... <val n>**  
 Reply: *no reply*

Example:

**!WMC 2 1 1 1 4** Sets to ON the DIG OUT OD3 output of the BASE15K card (id: 1)

**!WMC 2 1 1 1 0** Sets to OFF all DIG OUT outputs (OD1 ÷ OD8) of the BASE15K card (id: 1)

**!WSR** Command for writing a single register on a MODBUS device (*Write Single Register*). Specify the communication port <port> of the datalogger on which the device to be controlled is connected (e.g. for a BASE15K analogue base card, set: 2 = COM2), specify <id> the hardware of the MODBUS device (*Slave*), the register address <addr> and the value <val> to be set (word: 0..65535):

Command: **!WSR <port> <id> <addr> <val>**  
 Reply: *no reply*

**!WMR** Command for the multiple writing of registers on a MODBUS device (*Write Multiple Registers*). Specify the communication port <port> of the datalogger on which the device to be controlled is connected

(e.g. for a BASE15K analogue base card, set: 2 = COM2), specify <id> the hardware of the MODBUS device (*Slave*), the data start address <start>, the number <n> of registers to write and the values <val> to be set (word: 0..65535):

Command: **!WMR <port> <id> <start> <n> <val 1> <val 2> ... <val n>**  
 Reply: *no reply*

### 3.7.6 MODBUS protocol specification

The DA18K datalogger implements the standard *MODBUS RTU* and *MODBUS TCP* protocols in response to incoming requests on serial communication and Ethernet TCP/IP.

The tables below show the supported function codes for the MODBUS read and write commands and address mapping in relation to the variables in memory on the datalogger.

*Holding Registers* are used to read and write configuration parameters and *Input Registers* to read memory locations. The values are expressed in 32-bit *Floating point* encoding.

#### USER PARAMETERS

MODBUS function <b>03 (0x03) Read Holding Registers</b> <b>16 (0x10) Write Multiple Registers</b>				
Address	Flag	Type	Encoding value	Description
0x0000	Read–Write	16-bit word HIGH	32-bit Floating point (4 bytes)	Value of 1st parameter
0x0001	Read–Write	16-bit word LOW		
0x0002	Read–Write	16-bit word HIGH	32-bit Floating point (4 bytes)	Value of 2nd parameter
0x0003	Read–Write	16-bit word LOW		
0x.....	.....	.....	.....	.....
0x.....	.....	.....	.....	.....
0x0062	Read–Write	16-bit word HIGH	32-bit Floating point (4 bytes)	Value of 100th parameter
0x0063	Read–Write	16-bit word LOW		

#### MEMORY LOCATIONS

MODBUS function <b>04 (0X04) Read Input Registers</b>				
Address	Flag	Type	Encoding value	Description
0x0000	Read–Only	16-bit word HIGH	32-bit Floating point (4 bytes)	Value of location M0001
0x0001	Read–Only	16-bit word LOW		
0x0002	Read–Only	16-bit word HIGH	32-bit Floating point (4 bytes)	Value of location M0002
0x0003	Read–Only	16-bit word LOW		
0x.....	.....	.....	.....	.....
0x.....	.....	.....	.....	.....

0x2326	Read-Only	16-bit word HIGH	32-bit Floating point (4 bytes)	Value of location M9000
0x2327	Read-Only	16-bit word LOW		

In addition to the standard functions, a *User-Defined* function has been implemented to carry the *SIAP+MICROS Store & Forward* set of commands.

Given that the available range is from 65 to 72 and from 100 to 110 decimal, function code 65 has been chosen. The syntax of the function is described below:

**SIAP+MICROS command - User-Defined MODBUS function code 65 (0x41)**

**Request:**

Field	Size	Range value
Slave ID	1 Byte	0x00 to 0xF7, 0xFF
Function code	1 Byte	0x41
Bytes count	2 Bytes	0x0000 to 0xFFFF (N)
Data request	N Bytes	0x00 to 0xFF
CRC-16	2 Bytes	0x00 to 0xFF

**Valid response:**

Field	Size	Range value
Slave ID	1 Byte	0x00 to 0xF7, 0xFF
Function code	1 Byte	0x41
Bytes count	2 Bytes	0x0000 to 0xFFFF (N)
Data response	N Bytes	0x00 to 0xFF
CRC-16	2 Bytes	0x00 to 0xFF

**Error response:**

Field	Size	Range value
Slave ID	1 Byte	0x00 to 0xF7, 0xFF
Error code	1 Byte	0xC1
Exception code	1 Byte	0x01, 0x02, 0x03, 0x04
CRC-16	2 Bytes	0x00 to 0xFF

## 4 Regulations

---

### 4.1 Safety regulations

---

The detailed examination of the design and methods of implementation has made it possible to establish the risks that the product may present during its lifetime, if properly used, and therefore to define the essential requirements that apply to it. These requirements may be contained in one or more directives and must be met regardless of which directive they belong to. Two conditions are therefore necessary for application of a directive to a product:

- The product falls within its scope of application
- The product presents risks to which the essential requirements of the directive refer.

From the risk analysis conducted, described in the following pages, it emerged that the European directives applicable to the product in question are the following:

European directive	Title	Italian transposing law
2014/35/EU	Low Voltage Directive (LVD)	Legislative Decree no. 86 of 19 May 2016
2014/30/EU	Electromagnetic Compatibility (EMC) Directive	Legislative Decree no. 80 of 18 May 2016

The product in question falls with the scope of application of the Low Voltage Directive 2014/35/EU transposed in Italy with Legislative Decree no. 86 of 19 May 2016 and the Electromagnetic Compatibility (EMC) Directive 2014/30/EU transposed in Italy with Legislative Decree no. 80 of 18 May 2016, both of which came into force on 26 May 2016.

### 4.2 EMC

---

This equipment is designed in conformity with the requirements of the directives indicated in the EC declaration attached to the product.

## 5 Environmental conditions of use

The equipment is designed to be used according to the specifications in the following table:

<b>INTENDED USE AND LIMITS OF THE EQUIPMENT</b>	<b>AVAILABLE DATA/INFORMATION</b>
Intended use	The intended use is exclusively for the measuring of physical and chemical parameters for meteorology, agrometeorology, hydrometry, environmental and climate monitoring, remote control and automation of aqueducts, purifiers, sewers, etc., distributed logic control and automation systems, special applications for landslide control, microbiological and chemical processes, etc.
Reasonably foreseeable misuse and contraindications to use	Use in a domestic, consumer or hobby environment is classed as misuse, as is use by unqualified or inadequately trained persons.
Usage environment	Not intended for use in environments with the presence of explosive, corrosive and flammable gases and vapours.
Critical environmental factors	The environmental conditions for proper use are: <ul style="list-style-type: none"> <li>- Reference temperature: 20 °C</li> <li>- Operating temperature: -40 ÷ 80 °C</li> <li>- Maximum permissible relative humidity: 99% non-condensing</li> <li>- Storage temperature: 0 ÷ 60 °C</li> <li>- Storage humidity: maximum 80%</li> </ul>
Expertise or experience required of operators	Personnel must be qualified or properly trained and aware of the risks involved.

### NOTES

- Periodic updates are made to the information contained in this document and are included in new versions of the document.
- The manufacturer may make changes and/or modifications to the product described in this document at any time and without notice.
- All rights reserved. This document may not be reproduced or duplicated in full or in part without the manufacturer's permission.

## **6 Revision history**

---

The following table provides a description of the changes made to this document.

<b>Versione</b>	<b>Data</b>	<b>Aggiornamenti</b>
<i>04</i>	<i>16/05/2022</i>	<i>current version of the document.</i>

All the information content in this document are the current available at the printing phase. Siap+Micros S.p.A. reserve the rights to change the specifications without any advance notice.

## 7 Declaration of Conformity



MD 751.1 rev. 04

### EU Declaration of Conformity (DoC)

**Manufacturer:** SIAP+MICROS S.p.A.  
 Via del Lavoro, 1 – 31020 S. Fior (TV) – Italy  
<https://www.siapmicros.com/en/>

This declaration of conformity is issued under the sole responsibility of the manufacturer.

**Object of the declaration:**

Description	Product code/model
DA18K - Multifunction datalogger with WinCE embedded	PEM-e018a-DA18K

The object of the declaration described above is in conformity with the relevant Union harmonization legislation:

- 2014/30/EU Electromagnetic Compatibility (EMC)
- 2011/65/EU The Restriction of Hazardous Substances Directive (RoHSD)

The following harmonised standards and technical specifications have been applied:

**EMC references:**

EN 61326-1 2021-06	Electrical equipment for measurement, control and laboratory use - EMC requirements - General requirements
-----------------------	--

**RoHSD references:**

EN 63000 2016+AMD1:2022	Technical documentation for the assessment of electrical and electronic products with respect to the restriction of hazardous substances
----------------------------	--

**Date**  
 31-01-2023

**CEO**  
 Alex Stevanin

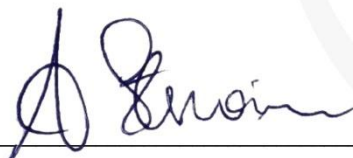

## Appendix A: Quick guide

### A.1 Setting the clock from the display

1. Close the SIAP+MICROS programme by pressing X, write YES and press OK:

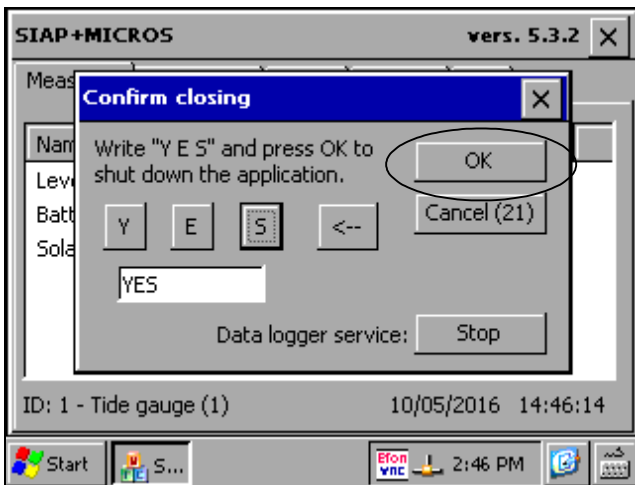
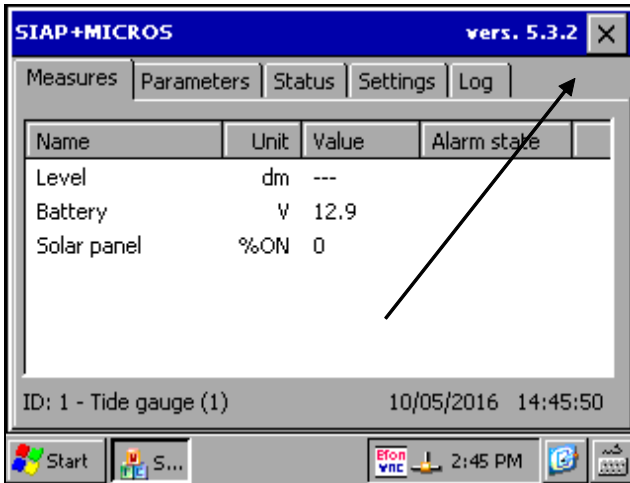

2. Open My Device:

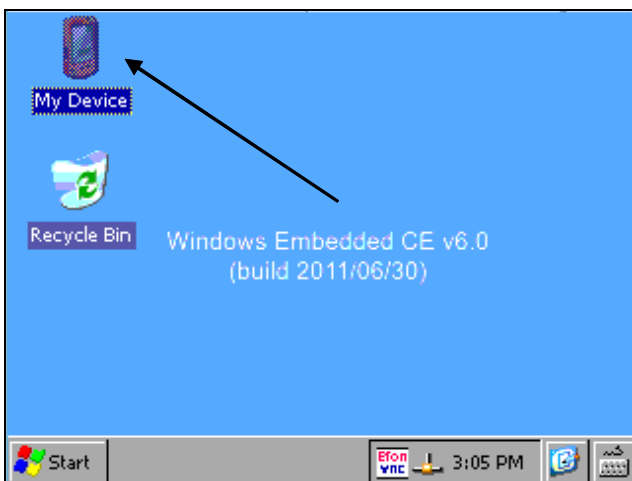

3. Open the *NandFlash* drive:

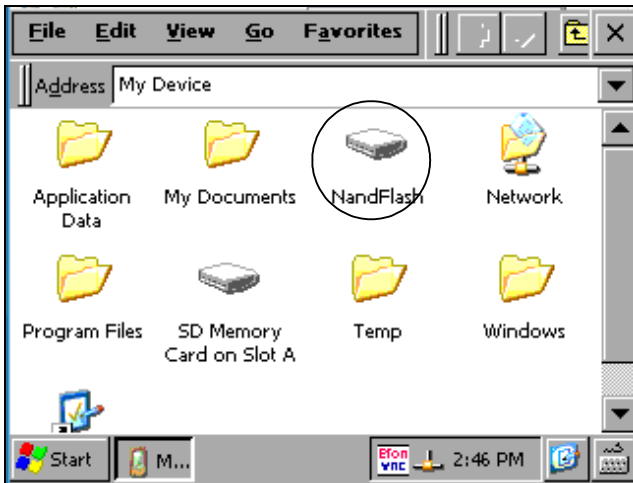

4. Open the *DA9000* folder:

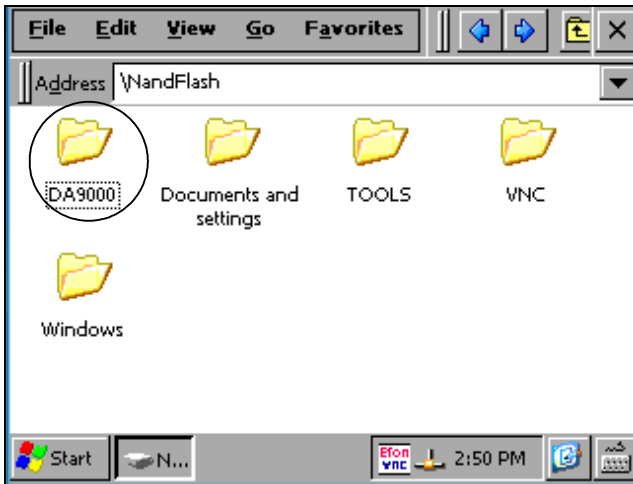

5. Start the *RTC* service programme:



6. Set the current time and date and press WRITE:

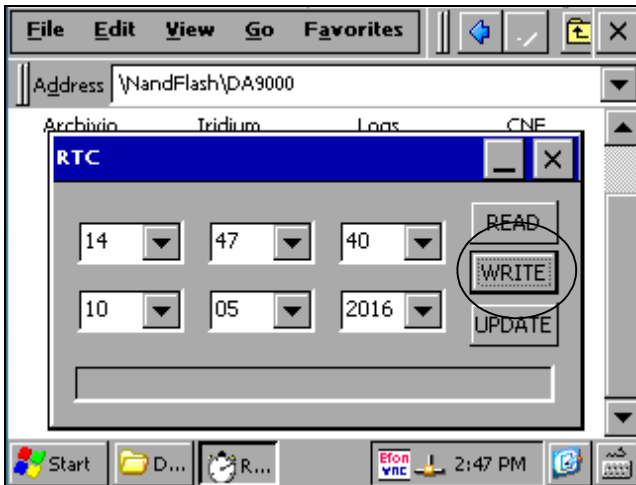

7. Turn the datalogger off and turn on again.

## A.2 Changing the configuration file from USB

1. Close the SIAP+MICROS programme by pressing X, write YES and press OK

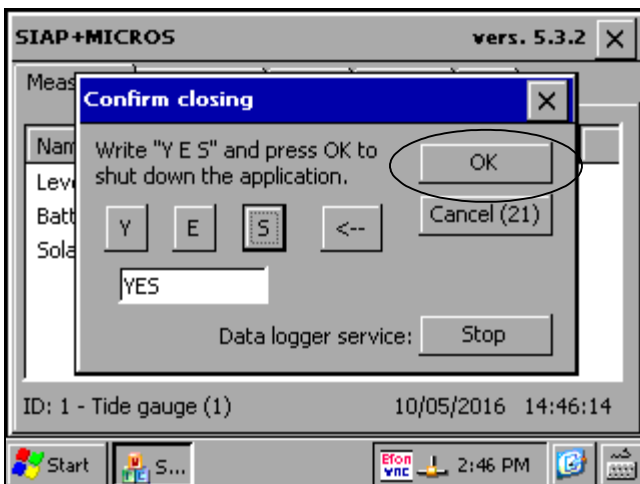
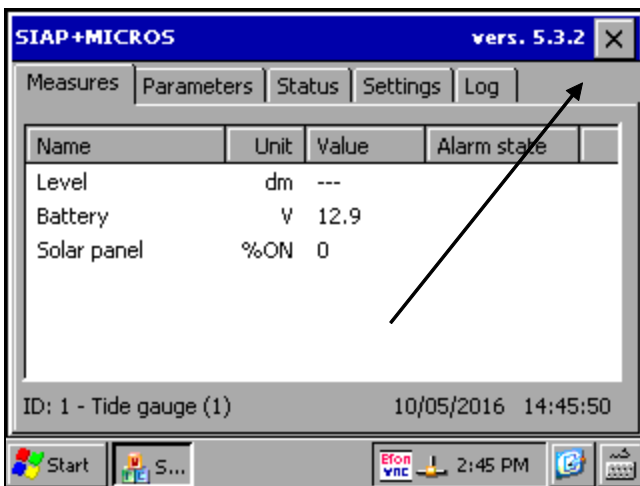

2. Open *My Device*:

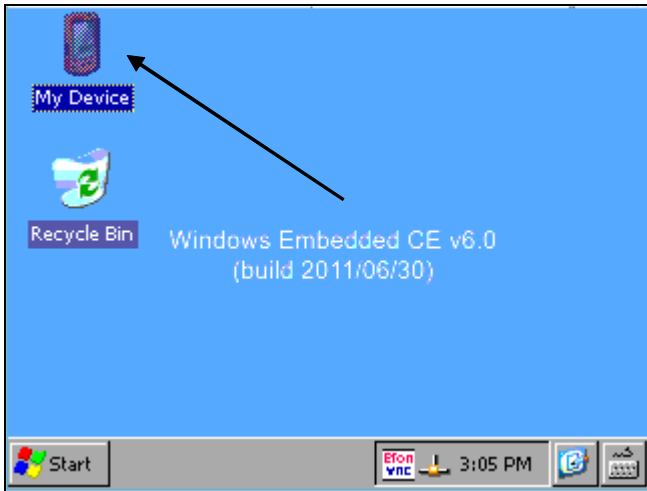

3. Insert the USB memory stick and wait for the system to recognise it. Open the “*Hard disk*” drive:



4. Select and copy the configuration file CNF and, if present, the initialisation file INI.:

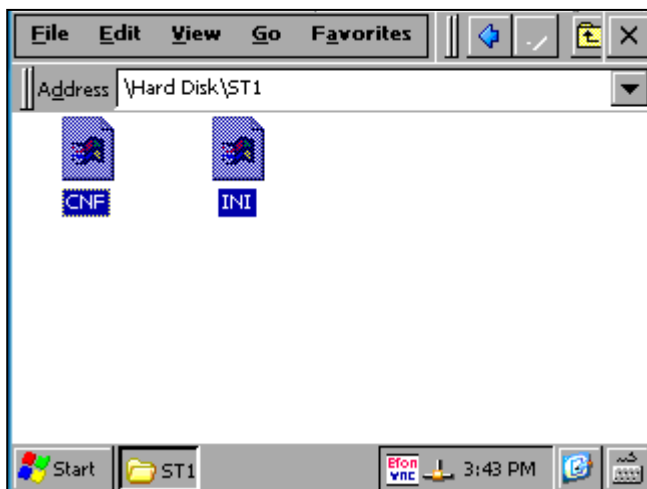

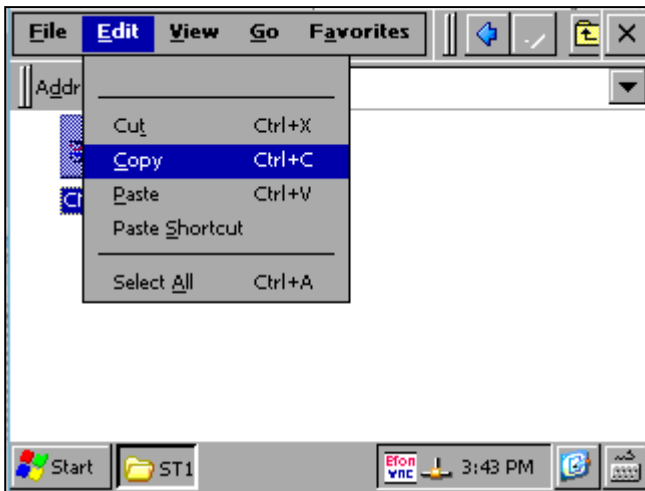

5. Open the *NandFlash* drive:

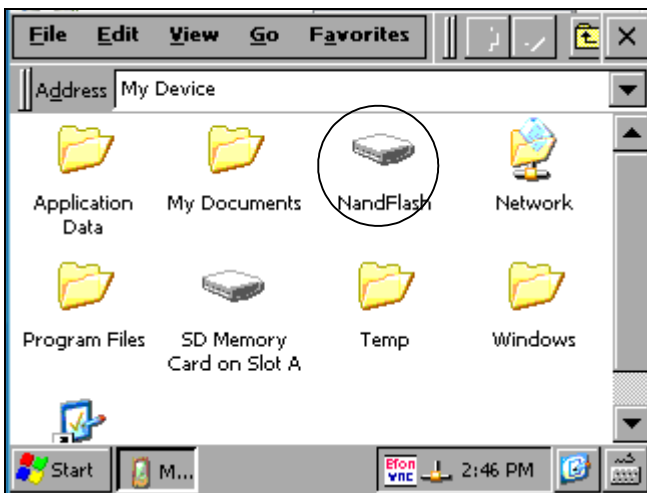

6. Open the *DA9000* folder



7. Copy the files into the *DA9000* folder and confirm with "Yes to All":

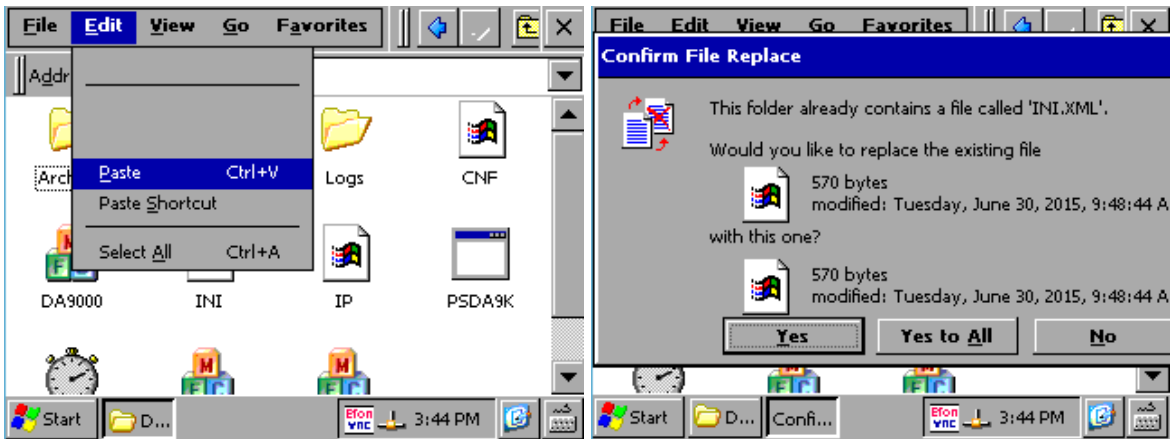

8. Remove the USB memory stick, turn the datalogger off and on again.

### A.3 Procedure for replacing the datalogger programme

To replace the datalogger programme with a more updated version, first close it by pressing the X button, write YES in the next window and press OK.



Insert the USB stick with the new programme, click the "My device" icon and select the "Hard Disk" drive, copy the programme file **DA9000.exe**, move to the **INandFlash\DA9000** folder and overwrite the file present.

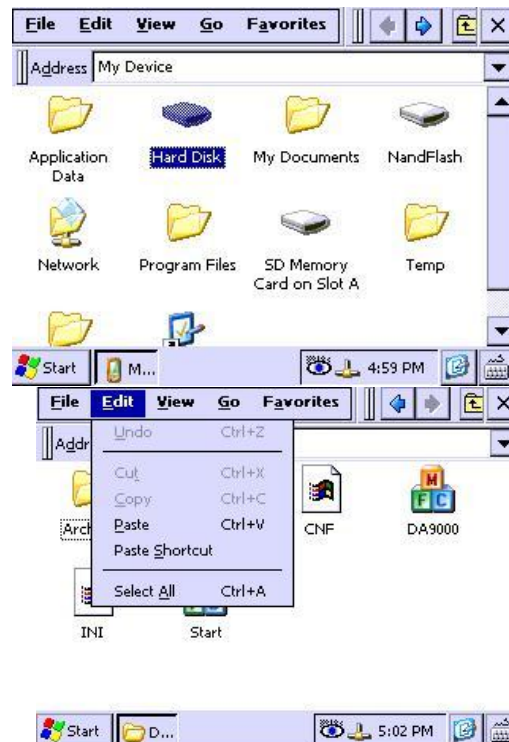
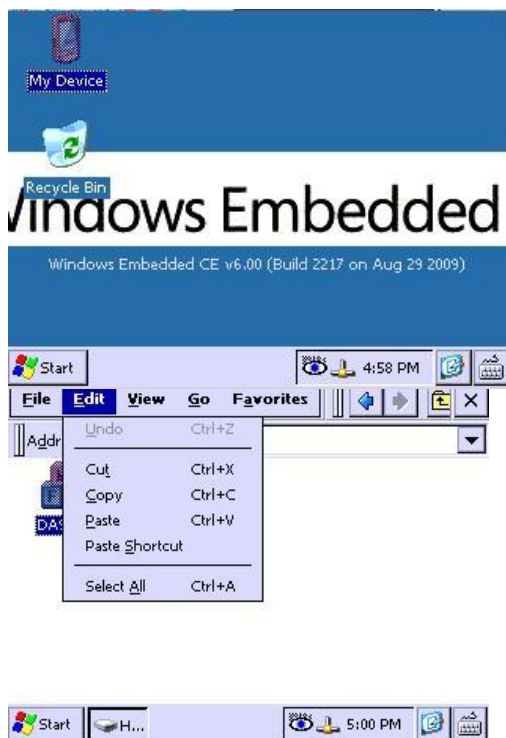

Once the copy is complete, restart the programme from Start.exe or turn the datalogger off and back on.