

e020a MicroSUM

e020b MicroSUM-LTE

Data acquisition datalogger

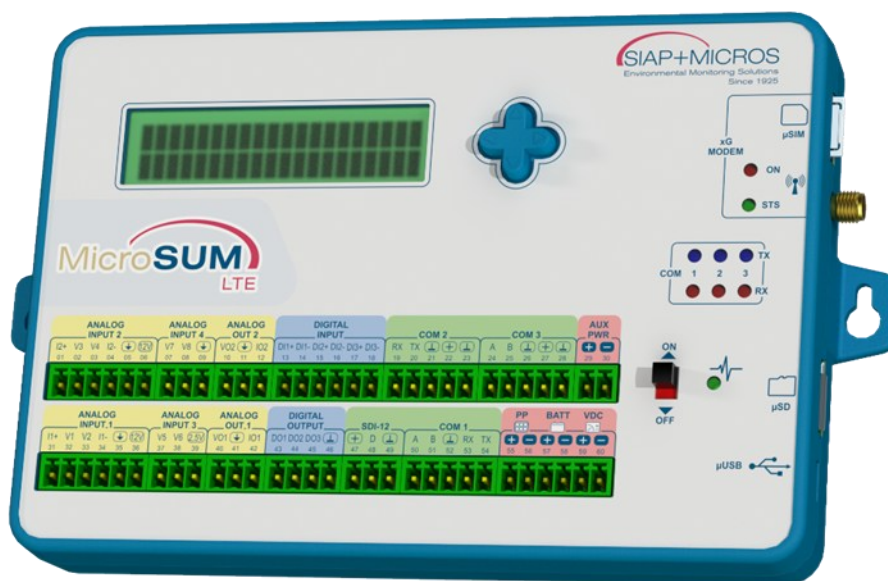

SIAP+MICROS

Index

1	Introduction	5
1.1	Safety.....	5
1.2	Waste disposal	7
1.3	Proper use of the device.....	7
1.4	Maintenance	7
1.5	Storage	7
1.6	Handling.....	8
1.7	Product overview	8
2	Characteristics and configuration	10
2.1	Parameters task.....	12
2.1.1	Datalogger ID	12
2.1.2	Serial channel	12
2.1.3	Modem channel	12
2.1.4	DEBUG channel.....	13
2.1.5	Datalogger parameter	13
2.2	Acquisition task.....	13
2.2.1	Acquisition job from serial line	13
2.2.2	Acquisition job from analog/digital	19
2.2.3	Acquisition job from rain gauge.....	23
2.2.4	Acquisition job from Modbus sensor with start measurement command	25
2.3	Transmission activity	28
2.3.1	FTP server transmission job	28
2.3.2	SMS transmission job	29
2.3.3	Satellite transmission job	29
2.3.4	Radio transmission work.....	30
2.4	Description of signal LEDs	30
3	Wiring.....	31
3.1	Analog inputs	31
3.2	Digital inputs	32
3.3	Analog outputs	34
3.4	Digital outputs	35
3.5	Serial ports.....	36
3.6	Power supplies	37
4	Examples of wiring with Siap+Micros sensors	39
4.1	TTEP-N (PT100 temperature sensor)	39
4.2	TTEPRH-S (MODBUS humidity temperature sensor).....	40
4.3	WINSON (MODBUS sonic anemometer).....	41
4.4	TBF (Leaf wetting)	43
4.5	TP (Tilting rain gauge)	44

4.6	TVV e TDV (Anemometer)	44
4.7	TLRx-I (Level radar sensor).....	46
5	Display	47
5.1	Main menu	47
5.2	Sensor History Menu	48
5.3	Sensor measurements menu	49
5.4	Menu constant editor	49
5.5	Modem C feature menu	49
5.6	Advanced functions menu	50
5.7	Events menu	52
5.8	NOR/SD fat menu.....	53
6	MODBUS RTU protocol.....	54
6.1	Standard commands.....	54
6.2	ASCII commands.....	56
6.3	Binary commands	59
6.3.1	Command 0 = Firmware version.....	59
6.3.2	Command 3 = Clock writing	60
6.3.3	Command 6 = Start UPDATE	60
6.3.4	Command 7 = UPDATE.....	60
6.3.5	Command 8 = Write identity	60
6.3.6	Command 9 = Read identity	61
6.3.7	Command 26 = Write calibration parameters	61
6.3.8	Command 27 = Read calibration parameters	61
6.3.9	Comand 28 = Emit frequencies	61
6.3.10	Comand 29 = Perform measurement by calibration	62
7	Data acquisition	63
7.1	Analog.....	63
7.2	Digital.....	63
7.3	Internal.....	63
7.4	Serial ports.....	64
7.5	Conversion formula.....	64
8	FTP transmission.....	66
8.1	XML file download for configuration update	66
8.2	HEX file download for firmware update	66
9	SMS Comand	67
10	Revision history	69
11	Declaration of Conformity	71
12	Appendices	73
12.1	Thresholds and Alarms.....	73
12.2	TP-Tilting rain gauge	74

12.3 USB use.....	76
12.4 Memory.....	76
12.5 Provisional maintenance	77
12.6 Power supply protections	77
12.7 Battery charger	78
12.8 Record layout.....	78
12.8.1 Normal record	79
12.8.2 Rain intensity record	79
12.8.3 Alarm record.....	80
12.9 Rainfall record.....	80
12.10 Meaning of LOG debug.....	81
13 DAK software for management of MicroSUM datalogger	89
13.1 Installation.....	89
13.2 Overview.....	89
13.3 Build a new configuration	90
13.4 Save configuration file	93
13.5 Open an XML configuration file	93
13.6 Setting up communications with the datalogger.....	93
13.7 Upload and download a configuration file	94
13.8 Checking of datalogger data and operation	95
13.8.1 Reading station ID	95
13.8.2 Reading parameters	95
13.8.3 Instant data request	96
13.8.4 Synchronize clock	97
13.8.5 Custom commands	97
13.8.6 Display	98
13.8.7 Data file conversion	98
13.9 Firmware upgrade.....	99
13.10 Language setting	99

1 Introduction

The Micro SUM datalogger is a local operating unit for environmental and weather/climate monitoring stations and can be directly interfaced with weather sensors, analysers, chemical-physical probes, etc.

It has been designed to meet the most varied needs of data acquisition, processing and transmission, from the simplest for individual stations to the most complex for networks of various types of stations managed by remote control centres.

The chosen manufacturing criteria are ease of use, both in terms of mechanics as well as configuration and operation, while maintaining ample versatility and future expandability.

Advantages of the Micro SUM datalogger:

- The latest generation “ARM Cortex M4 Ultra-low-power STM32L4” calculation system provides remarkable processing capacity with ultra-low power consumption.
- Built-in battery charger, and power management for automatic and protected services.
- Acquisition of up to 8 analog sensors and 3 digital sensors.
- High interconnection flexibility with measurement transducers through RS485, RS232 and SDI-12 interfaces.
- Integrated UMTS transmission system and optionally Iridium, Goes or Meteosat satellite transmission, or UHF radio transmission.
- Possibility of remote programming (firmware and configuration updating) and local programming via USB.
- High data recording autonomy.

1.1 Safety

Read these safety instructions carefully before using the product:

- The warranty shall be void if the product is used in a manner contrary to the instructions provided in this manual. Do not disassemble the product;
- Any sign of tampering will affect validity of the warranty.
- Only use the devices according to the instructions provided in this manual (environmental management and operation, wiring, installation, etc.).
- The correct and safe operation of the device can only be guaranteed if it is transported, stored, operated and handled appropriately. The same goes for maintenance of the product.
- The radio modem must only be operated at frequencies allocated by local authorities and must not exceed the maximum output power allowed for a work cycle. SIAP + MICROS and its distributors shall not be held responsible if the products it manufactures are used illegally.
- Do not install the device near a heat source or in damp conditions, and avoid contact with direct sunlight.

- The device must not be exposed to aggressive chemicals or solvents which may damage the plastic or corrode the metal parts.
- Maintenance must only be carried out by qualified and well-trained personnel.
- Ensure that the device is turned off before performing any operation on it.

The instrument does not present any specific risks related to its construction. However, given the normal integration of the instrument within a station, various risks may arise in relation to the installation and maintenance activities of the acquisition system, particularly in the event of installation on sites which present specific risks such as installations on building roofs, on bridges, in environments subject to chemical and/or biological hazard or in environments with traffic flow.

A careful risk assessment should be carried out by the installation company in relation to the installation and service environment of the device, taking into consideration the eventual station in its entirety, not just the acquisition device.

The instruments should be installed by qualified technicians according to best practice, using correctly sized supports designed for the specific purpose.

When carrying out installation operations, check the suitability of the surrounding environment and compliance with local safety regulations.

Only use qualified and trained personnel for installation and maintenance activities.

The manufacturer assumes no liability for malfunctions resulting from non-observance of the instructions, tampering, uses not described in this manual, improper use of the device, or use by untrained operators.

Carefully read the instructions and intended uses (fields of application), making sure they are understood before proceeding to install the device.

Check the integrity of the instrument to be installed, prepare the equipment required for processing and wear the necessary PPE.

Suitable measures should be taken to prevent access by unauthorised personnel (untrained and uninformed) during the installation, maintenance and decommissioning phases.

Take special precautions to prevent risks from falling objects during both the installation and operation phases.

Do not perform any activity in the event of adverse weather conditions.

During maintenance, particularly if the station is not frequented, visually check for the absence of dangerous insects, and if any are found, use appropriate insecticides.

Check for the presence of any fauna in the vicinity of the station.

Only use original SIAP+MICROS spare parts.

The instrument is generally used in stations equipped with solid-state batteries. It is advisable to assess the risks relating to the management of battery life and provide for special kits for disposal in the remote event of electrolyte leakage.

The instrument is not classified as suitable (according to Directive 2014/34/EU) for use in potentially explosive atmospheres pursuant to Directive 99/92/EC.

SIAP+MICROS strives to minimise the health and safety risk in all phases of the product's life. The user assumes all risks relating to improper use of the instrumentation for the entire life cycle, intended as installation, use, maintenance, decommissioning and disposal.

1.2 Waste disposal



In compliance with Directive 2012/19/EU of the European Parliament and of the Council on waste electrical and electronic equipment, this product must be disposed of by taking it to a designated collection point for the recycling of electrical and electronic equipment.

For further information on the closest recycling centre, please contact the nearest local authority offices.

1.3 Proper use of the device

INTENDED USE AND LIMITS OF THE DEVICE	AVAILABLE DATA / INFORMATION
Intended use	Intended use includes exclusively the acquisition, transmission and calculation of physical and chemical parameters for meteorology, agrometeorology, hydrometry, environmental and climate monitoring, remote control and automation of aqueducts, purifiers, sewers, etc., distributed control and automation systems, special applications for landslide monitoring, microbiological and chemical processes, etc.
Reasonably foreseeable incorrect uses and contraindications of use	Use in a home or hobby environment, and use by unqualified or not suitably trained persons, is incorrect.
Usage environment	Not intended for use in environments with explosive, corrosive and flammable gases or vapours.
Possible critical environmental factors	The environmental conditions for correct use are: <ul style="list-style-type: none"> • Reference temperature: 20° C • Operating temperature: -30 +80 °C • Maximum permissible relative humidity (non-condensing): 100% • Storage temperature: -30 +80 °C • Humidity from storage: 90% • Maximum altitude: 4000m • Pollution degree: 2
Professionalism or experience required of operators	Personnel must be qualified or appropriately trained and informed about the possible risks.
Space limitations	The acquisition system is usually installed inside steel or plastic electrical panels accessible only by qualified personnel.

1.4 Maintenance

Disconnect all the connection cables before cleaning the datalogger. Use a soft and dry cloth for cleaning. Never use damp cloths, solvents, water or other liquids.

1.5 Storage

If the device is not to be used for an extended period of time (for example, a year), disconnect all the cables from the device, put it into a plastic bag (preferably antistatic) along with a sachet of dehydrating salts and seal the bag with tape. Affix appropriate information on the bag regarding its contents, with the words "HANDLE WITH CARE". It is recommended to regularly replace the dehydrating salts.

Store the datalogger in an environment with a temperature between 0-60°C with humidity not exceeding 80% and raised from the ground. Make sure that the datalogger is in a stable position and that it cannot be

damaged or moved due to incompetence or distraction. Do not overlap the datalogger on other instruments or weights and in any case make sure the underlying support is solid and stable.

1.6 Handling

Handle with care as blows to the instrument during transportation may change its performance compared with that of the factory-calibrated instrument.

On arrival of the goods, immediately check the integrity of the packaging and report any damage to the manufacturer. It is recommended to always use the original packaging during transportation.

1.7 Product overview

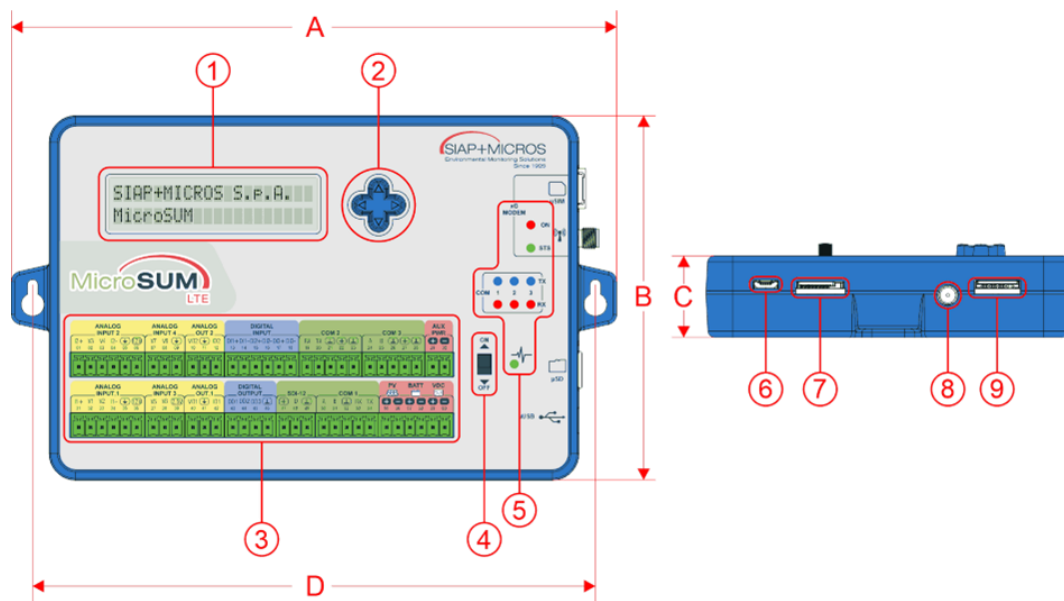

Dimensions and Weight

Overall dimensions (**AxBxC**): **183 x 110 x 28,5 mm**

Distance between fixing points, it is recommended the use of M3 screws with cylindrical head, (**D**): **170 mm**

Weight: **260 gr**

Main Elements

- (1) 20 characters x 2 rows Display LCD
- (2) Navigation Joystick
- (3) Connections terminals
- (4) ON/OFF switch
- (5) Status Led
- (6) μUSB connector
- (7) μSD Card Slot (Push-Push)
- (8) SMA antenna connector
- (9) μSIM Card Slot (Push-Pull)

Inserting and removing SD card:

- Insert the SD card into the memory card slot and push in the card until you hear a clicking sound.
- Push lightly until you hear a clicking sound to spring out the card and then remove it from the slot.

Inserting and removing SIM card:

- Gently slide the SIM card into the card slot.
- Slide the SIM out of the slot without pushing.

2 Characteristics and configuration

The Micro SUM is extremely compact, incorporating in single object the terminal blocks required for all wiring, the display equipped with joystick, the battery charger power supply and the UMTS/LTE modem. The main features are summarised below:

Display

- Date and time, instantaneous data and processed data. Possibility of performing switching operations and various tests.

Pre-treatment of data (instantaneous measurements)

- Data validation (plausibility check of measurement values)
- Data processing (corrective formulas, calculation algorithms, etc ...)

Statistical calculations (recorded measurements)

- The Micro SUM acquires the instantaneous values of the measured quantities and stores them in a temporary archive. When a set time base expires, the set of stored values is processed to calculate the desired statistical data. The acquisition sequence and recording interval can be defined for each measurement. The main statistical parameters are: instantaneous measurement, arithmetic average, minimums and maximums, accumulation, period, frequency, integral, mean vector, trigonometric average, etc.

Storage

- The data is first parked in a temporary area, typically hourly, and then stored permanently on an internal FAT drive. If there is also a removable SD card, the data is also stored there.
- Memory management in circular mode (deletion of the oldest data when the memory space exceeds 90%).
- Compact binary structure record layout.

Communication/Transmission

- Data transmission via internal UMTS/LTE modem.
- Optional transmission via UHF radio or satellite terminal.
- Transmission of data on FTP servers and SMS alarms.
- Communication protocols: TCP-IP, FTP, MODBUS, SDI-12...

Self-diagnostics

- The Micro SUM has a set of procedures for the following controls:
- Checking of single acquisition channel.
- Checking of storage area.
- Checking of communication with transmission system.

- Management of correct MPPT working point.

Configurable parameters

- Name and engineering units.
- Minimum and maximum values detectable by the sensor (begin scale and end scale).
- Number of decimals after the comma that will define the measurement.
- Corrective formula: conversion formula to obtain the value in engineering units from the input electrical signal.
- Deadlines and calculations that can be generated.
- All information needed for transmission of data

Alarm management

- Option to define various minimum and maximum alarm thresholds with hysteresis for return.
- Option to send SMS alarms for changing operation deadlines for data transmission

Before proceeding with the description of the datalogger and how to configure it, it is necessary to define several terms that will be used and which characterise the general view of the system.

Tasks The Micro SUM datalogger performs several basic tasks. Each task is distinct from the others and is configured individually even if the results of one task can be used by another. There are currently two tasks implemented: **acquisition** and **transmission**. The former has the task of collecting data, processing it and storing it in the permanent internal storage, while the latter has the task of communicating and/or transmitting the data collected in the storage to the users of this information.

Job Each task is composed of a certain number of distinct jobs. Each job has its own unique specific configuration that determines its operation. Each job runs independently and at the same time as all the others, unless it interacts with resources that cannot be shared. For example, a data acquisition job from one serial port can run at the same time as another job using a different port, but it must be deferred if the resource is in use by another job. In some cases the delay is in milliseconds, while in others it is several seconds. This characteristic must be taken into account when designing and configuring the system.

Phase Each job is composed of a certain number of distinct phases. Each phase has its own unique specific configuration that determines its operation. Each phase runs in sequence according to its configuration order.

We can say that there is a hierarchy of a maximum of three levels between Tasks/Jobs/Phases which lead to a logical and conceptual simplification of both the configuration and the configurator.

Each job and each phase are characterised by a descriptive name, a parent-child hierarchy and an enable status. Each one can be individually activated and therefore deactivated without necessarily having to remove it. The parameters can be changed for all jobs and all phases:

Name Only a descriptive name of the job or phase, to be used for clarity and completeness;

Enabled A property that enables operation. If used on one job it is valid for itself and for all the phases defined below.

Tasks are continuously monitored and managed by internal events, such as messages received, measured fronts and passing times. Generally, the passing of time is measured per second, i.e. the internal clock controls the dormant tasks every second and reactivates them if applicable.

There is a task named Parameters which does not represent a real task but contains the definition of several basic jobs that characterise the entire Micro SUM datalogger, as shown in detail here below.

2.1 Parameters task

As just mentioned, the Parameters task is not a real task, but it introduces several important parameters concerning the overall operation of the system. A better name for it could be “Global task”.

2.1.1 Datalogger ID

In this mandatory and unique section, we can give an identity to recognise the datalogger, i.e. it is possible to set the following parameters:

Site	Descriptive string of up to 30 characters of the location where the datalogger is mounted. It is used, for example, in sending SMS alarms.
SiteID	Compact string of up to 10 characters of the location. Has a use where compactness and uniqueness is required. Is used, for example, as a preamble in the names of files sent over FTP and where necessary, there must be no spaces.
ModbusID	Identification number used in the MODBUS RTU (1-254) dialogue protocol.
Store Event	Parametro che definisce in quale memoria salvare i record eventi: 0=disabilitato, 1=SD card, 2= NOR flash e SD card.

2.1.2 Serial channel

In this section it is possible to configure the serial channels where the datalogger responds with a certain protocol. There can be more than one:

Type	Protocol used on this channel: Modbus, Iridium, Goes, Metosat, etc.
COM	On which serial port it is configured: COM1 (Rs232/485), COM2 (Rs232), COM3 (Rs485).
Baud rate	Serial port speed, generally from 1200 to 115200.
nBit	Number of bits, generally 7 or 8.
Parity	Parity to be used, generally none, even or odd.
nStop	Stop number, generally 1, 1.5 or 2.

2.1.3 Modem channel

In this section it is possible to configure the internal UMTS/LTE modem:

InitModem	String of initial commands of the modem, up to 100 characters. This string is not strictly necessary, but it is possible to send commands to the modem in advance. The commands are separated by semicolons.
APN	ACCESS POINT definition string. Depends on the SIM manager.
NTP	Name of NTP server that provides the system clock to be periodically checked.
OffsetNTP	Local time offset of the NTP datalogger expressed in hours with respect to the NTP server
Tsynch	Maximum phase shift time before updating the datalogger time,
Option	Allows to set different modem behaviors (0=normal, 1=7802, ..) ¹ .

¹ Option field is no longer used since fw version 0.18.22.

NewWaitTime Maximum waiting time in seconds for network registration².

2.1.4 DEBUG channel

In this section it is possible to configure a serial channel to be used as a continuous debug log:

COM The serial port on which the debug service is configured: COM1 (Rs232/485), COM2 (Rs232), COM3 (Rs485).

LogVerbose Level of detail of log produced: 0=minimum, 1=medium 2=maximum.

Speed is set automatically at baud rate 38400 with 8 bits, no parity and 1 stop bit.

A serial channel with MODBUS protocol can also be used. In this case, use the previous settings used on the serial channel. If an external device interrogates the datalogger on this shared channel, debugging is temporarily disabled for 30 seconds, so as not to interfere.

The datalogger is equipped with a USB connection. When a PC is connected, the datalogger shows a virtual serial port that presents both a DEBUG and MODBUS channel at the same time.

When the datalogger is turned on, before loading the configuration that enables debugging on a port, COM1 is temporarily set as the debug channel at a baud rate of 38400.

2.1.5 Datalogger parameter

In this section it is possible to configure a datalogger parameter. Parameters are identified by a number (index) which is used to get the value of the corresponding parameter within formulas.

Value String containing the numeric value assigned to the parameter,

Index Numeric identifier used to refer to the parameter,

Unit Unit of measurement of the parameter.

2.2 Acquisition task

The acquisition task has the job of collecting the data from the field and inserting it into the internal memory. There are about twenty jobs to choose from and three of these are currently possible:

1. Acquisition job from a serial line
2. Acquisition job from analog/digital
3. Acquisition job from rain sensor

Only the acquisition jobs from serial and analog can be multiple, even if they involve the same physical channel. Only acquisition from the rain gauge must be unique.

2.2.1 Acquisition job from serial line

This job allows to acquire a certain amount of data from sensors connected in parallel on the same serial line. They are managed in the same way, both as protocol and acquisition times, as well as calculations.

This job is characterised by the following operating parameters, valid for all the phases defined below:

² Available from fw version 0.24.3

DTC	Delta T sampling in seconds, i.e. how often to start the job to extract a single elementary measurement.
DTR	Delta T recording in seconds, i.e. how often to record a calculation of elementary data in the internal memory (DTC must obviously be a submultiple of DTR).
Validity	A percentage from 0 to 100 determining how much valid data must exist to obtain a measurement considered valid.
MskElab	This parameter allows to determine which calculations must be performed, if possible (for example, average, minimum and maximum, standard deviation, scalar and vector trigonometry, gust, etc.), as specified in detail below.
COM	On which serial port to work: COM1 (Rs232/485), COM2 (Rs232), COM3 (Rs485), COM4 (SDI12). Two jobs sharing the same port are performed one after the other.
Baud rate	Port speed, generally from 1200 to 115200,
nBit	Number of bits, generally 7 or 8.
Parity	Parity to be used, generally none, even or odd.
nStop	Stop number, generally 1, 1.5 or 2.
Protocol	Which protocol to use for all phases. For now there are two: Modbus or SDI-12,
nRetry	Maximum number of attempts to be made for each phase.
Tsupply	Power pre-ignition time. The serial ports have a power supply output, only COM1 does not have one. With this parameter it is established how many seconds power must be supplied before measuring. It will be turned off after measuring. If set to zero, power supply will still be present. Obviously if there are multiple jobs on the same serial channel, consistency is required and it should always be left on.

This job is checked and activated every second. When it starts (DTC) it performs all its phases in the shortest time possible, temporarily stores the partial results and at the end (DTR) generates calculations, starting a new cycle.

The calculation “window” determines the calculations to be produced, where possible, for all sensors:

Last	last data acquired
Average	mathematical average
Maximum	maximum value of samples acquired
Minimum	minimum value of samples acquired
DevST	standard deviation of samples acquired
Vector	for wind sensors only, the recording of vector trigonometry values
Scalar	for wind sensors only, the recording of scalar trigonometry values
Gust	for wind sensors only, the recording of gust values.

This window is also used in other jobs.

The possible phases are as follows:

2.2.1.1 MODBUS phase

This phase describes a single data of a sensor with Modbus protocol.

This phase is characterised by the following operating parameters:

MeasureID	Measurement identification. This number is unique and will be used in the recording of data.
Specific	This parameter allows to assign to this sensor a specific trigonometric meaning. It signals if this sensor is normal, or a wind direction or speed. During trigonometric calculations it allows to correctly match the two vector components.
Address	MODBUS address of the sensor connected to the serial channel (1-247),
FN	Which MODBUS function to recall. It is generally 3 (Read Holding Registers) or 4 (Read Input Registers),
StartRegister	Which register to start the data request from.
nRegister	How many registers to request. If other phases have Address, Function, Start and nRegisters identical to this phase, a single call is made to save time, and the answer incorporating all answers will be used for all.
DataType	How to translate this data, whether a 2- or 4-byte integer, in floating point and the reading direction.
Register	On which register to start the answer. It must be contained with Start and nRegisters.
Timeout	Specifies in milliseconds, in case of no response, after how long to repeat a call to this sensor.
nDec	With how many decimals to show and use the final stored number.
Formula	It is possible to set a calculation formula. The determined value is identified by M0.

The wind sensors can record three values, vector, scalar and gust, as specified in the job, so “MeasurementID” is used as a starting point in the identifier to be used in the data, as follows.

Vector	MeasurementID used
Scalar	MeasurementID+1 used
Gust	MeasurementID+1 used

Furthermore, each sensor phase has matched the following “Threshold parameters”:

LimMax	If set, this parameter is the maximum numerical value for the number to be considered valid.
LimMin	If set, this parameter is the minimum numerical value for the number to be considered valid.
AllSup	If set, this parameter is the numerical value to be considered as an upper alarm level.
AttSup	If set, this parameter is the numerical value to be considered as a higher level of attention. Has lower priority than the upper and lower alarm.
AttInf	If set, this parameter is the numerical value to be considered as a lower level of attention. Has lower priority than the upper and lower alarm and the higher attention level.
AllInf	If set, this parameter is the numerical value to be considered as a lower alarm level. Has lower priority than the upper alarm.
Hysteresis	If set, this parameter is the numerical value to be considered as hysteresis to be applied on all levels for correct return without immediately raising an alarm or attention.

VO1	Expression to convert the acquired measure, after being processed by the processing formula, into a voltage value expressed in mV in the range 0 – 2500mV. Resulting value is applied to the analog output voltage VO1. If the expression is empty, the analog output is not used. ³
VO2	Expression to convert the acquired measure, after being processed by the processing formula, into a voltage value expressed in mV in the range 0 – 2500mV. Resulting value is applied to the analog output voltage VO2. If the expression is empty, the analog output is not used. ³
IO1	Expression to convert the acquired measure, after being processed by the processing formula, into a current value expressed in mA in the range 0 – 20mA. Resulting value is applied to the analog output current IO1. If the expression is empty, the analog output is not used. ³
IO2	Expression to convert the acquired measure, after being processed by the processing formula, into a current value expressed in mA in the range 0 – 20mA. Resulting value is applied to the analog output current IO2. If the expression is empty, the analog output is not used. ³
DO1	Specifies if digital output DO1 is enabled and the activation condition (warning or alarm). If set to 1 (warning), DO1 is activated if measurement status is warning or alarm. If set to 2 (alarm), DO1 is activated if measurement status is alarm. If set to 0, DO1 is not enabled. ³
DO2	Specifies if digital output DO2 is enabled and the activation condition (warning or alarm). If set to 1 (warning), DO2 is activated if measurement status is warning or alarm. If set to 2 (alarm), DO2 is activated if measurement status is alarm. If set to 0, DO2 is not enabled. ³
DO3	Specifies if digital output DO3 is enabled and the activation condition (warning or alarm). If set to 1 (warning), DO3 is activated if measurement status is warning or alarm. If set to 2 (alarm), DO3 is activated if measurement status is alarm. If set to 0, DO3 is not enabled. ³

2.2.1.2 SDI-12 phase

This phase describes a single sensor's data with SDI-12 protocol.

This phase is characterised by the following operating parameters:

MeasureID	Measurement identification. This number is unique and will be used in the recording of data.
Specific	This parameter allows to assign to this sensor a specific trigonometric meaning. It signals if this sensor is normal, or a wind direction or speed. During trigonometric calculations it allows to correctly match the two vector components.
Address	SDI-12 address of the sensor connected to the serial channel (0-9, A-Z. a-z).
AM	Which command to send to start measuring (aM! aM1!-aM9! aMC! aMC1-aMC9!).
AC	Start concurrent measurement command (aC!, aC1!-aC9!, aCC!, aCC1!-aCC9!) ⁴ .
AD	On which multiple data row/channel the data will be tracked (aD0!-aD9!)
Position	In which position of the data row/channel the data will be tracked (1..n)
Timeout	Specifies in milliseconds, in case of no response, after how long to repeat a call to this sensor.

³ Available from fw version 0.25.9

⁴ Available from fw version 0.24.3

nDec With how many decimals the final stored number must be seen and truncated.

Formula It is possible to set a calculation formula. The determined value is identified by M0.

Sensors with the same address and AM parameter, with command to send, are executed simultaneously, generated a single query.

Start measurement commands (AM) and start concurrent measurement commands (AC) are mutually exclusive. If AM command is defined, AC should be set to *Unused*, while if AC command is defined, AM should be set to *Unused*. If both are defined, only AM command is considered. If both are set as *Unused*, aM! command is used as the default.

The wind sensors can record three values, vector, scalar and gust, as specified in the job, so "MeasurementID" is used as a starting point in the identifier to be used in the data, as follows:

Vector	MeasurementID used
Scalar	MeasurementID+1 used
Gust	MeasurementID+2 used

Furthermore, each sensor phase has matched the following "Threshold parameters":

LimMax If set, this parameter is the maximum numerical value for the number to be considered valid.

LimMin If set, this parameter is the minimum numerical value for the number to be considered valid.

AllSup If set, this parameter is the numerical value to be considered as an upper alarm level.

AttSup If set, this parameter is the numerical value to be considered as a higher level of attention. Has lower priority than the upper and lower alarm.

AttInf If set, this parameter is the numerical value to be considered as a lower level of attention. Has lower priority than the upper and lower alarm and the higher attention level.

AllInf If set, this parameter is the numerical value to be considered as a lower alarm level. Has lower priority than the upper alarm.

Hysteresis If set, this parameter is the numerical value to be considered as hysteresis to be applied on all levels for correct return without immediately raising an alarm or attention.

VO1 Expression to convert the acquired measure, after being processed by the processing formula, into a voltage value expressed in mV in the range 0 – 2500mV. Resulting value is applied to the analog output voltage VO1. If the expression is empty, the analog output is not used.³

VO2 Expression to convert the acquired measure, after being processed by the processing formula, into a voltage value expressed in mV in the range 0 – 2500mV. Resulting value is applied to the analog output voltage VO2. If the expression is empty, the analog output is not used.³

IO1 Expression to convert the acquired measure, after being processed by the processing formula, into a current value expressed in mA in the range 0 – 20mA. Resulting value is applied to the analog output current IO1. If the expression is empty, the analog output is not used.³

IO2 Expression to convert the acquired measure, after being processed by the processing formula, into a current value expressed in mA in the range 0 – 20mA. Resulting value is applied to the analog output current IO2. If the expression is empty, the analog output is not used.³

- DO1** Specifies if digital output DO1 is enabled and the activation condition (warning or alarm). If set to 1 (warning), DO1 is activated if measurement status is warning or alarm. If set to 2 (alarm), DO1 is activated if measurement status is alarm. If set to 0, DO1 is not enabled.³
- DO2** Specifies if digital output DO2 is enabled and the activation condition (warning or alarm). If set to 1 (warning), DO2 is activated if measurement status is warning or alarm. If set to 2 (alarm), DO2 is activated if measurement status is alarm. If set to 0, DO2 is not enabled.³
- DO3** Specifies if digital output DO3 is enabled and the activation condition (warning or alarm). If set to 1 (warning), DO3 is activated if measurement status is warning or alarm. If set to 2 (alarm), DO3 is activated if measurement status is alarm. If set to 0, DO3 is not enabled.³

2.2.2 Acquisition job from analog/digital

This job allows to acquire a certain amount of data from analog/digital type sensors. They are all managed in the same way, in terms of both acquisition and processing times.

This job is characterised by the following operating parameters, valid for all the phases defined below:

DTC	Delta T sampling in seconds, i.e. how often to start the job to extract a single elementary measurement.
DTR	Delta T recording in seconds, i.e. how often to record a calculation of elementary data in the internal memory (DTC must obviously be a submultiple of DTR).
Validity	A percentage from 0 to 100 determining how much valid data must exist to obtain a measurement considered valid.
MskElab	This parameter allows to determine which calculations must be performed, if possible (for example, average, minimum and maximum, standard deviation, scalar and vector trigonometry, gust, etc.), as specified in detail below.
Supply	The power supply that needs to be activated before taking measurements. Two power supplies are possible, the one available on Analog 1 and the one on Analog 2.
Tsupply	Power pre-ignition time. With this parameter it is established how many seconds power must be supplied before measuring. It will be turned off after measuring. If set to zero, power supply will still be present. Obviously if there are multiple jobs using the same power supply, consistency is required and the channel should always be left on.

This job is checked and activated every second. When it starts (DTC) it performs all its phases in the shortest time possible, temporarily stores the partial results and at the end (DTR) generates calculations, starting a new cycle. The calculation "window" determines the calculations to be produced, where possible, for all sensors:

Last	last data acquired
Average	mathematical average
Maximum	maximum value of samples acquired
Minimum	minimum value of samples acquired
DevST	standard deviation of samples acquired
Vector	for wind sensors only, the recording of vector trigonometry values
Scalar	for wind sensors only, the recording of scalar trigonometry values
Gust	for wind sensors only, the recording of gust values

This window is also used in other jobs.

The possible phases are as follows:

2.2.2.1 Analog phase

This phase describes sensor data connected to an analog input.

This phase is characterised by the following operating parameters:

MeasureID	Measurement identification. This number is unique and will be used in the recording of data.
------------------	--

Specific	This parameter allows to assign to this sensor a specific trigonometric meaning. It signals if this sensor is normal, or a wind direction or speed. During trigonometric calculations it allows to correctly match the two vector components.
PhysicalID	Address of the sensor connected to the analog channel. Allows to choose between the 8 individual channels, the 4 differentials or the 2 PT100s.
Filter	In order to reduce the noise present, it is possible to specify how long measuring should last, with times from microseconds to tens of seconds.
Buffered	Allows to enable the buffering function of the ADC peripheral.
nDec	With how many decimals to show and use the final stored number.
Formula	It is possible to set a calculation formula. The determined value is identified by M0.

The wind sensors can record three values, vector, scalar and gust, as specified in the job, so “MeasurementID” is used as a starting point in the identifier to be used in the data, as follows.

Vector	MeasurementID used
Scalar	MeasurementID+1 used
Gust	MeasurementID+1 used

Furthermore, each sensor phase has matched the following “Threshold parameters”:

LimMax	If set, this parameter is the maximum numerical value for the number to be considered valid.
LimMin	If set, this parameter is the minimum numerical value for the number to be considered valid.
AllSup	If set, this parameter is the numerical value to be considered as an upper alarm level.
AttSup	If set, this parameter is the numerical value to be considered as a higher level of attention. Has lower priority than the upper and lower alarm.
AttInf	If set, this parameter is the numerical value to be considered as a lower level of attention. Has lower priority than the upper and lower alarm and the higher attention level.
AllInf	If set, this parameter is the numerical value to be considered as a lower alarm level. Has lower priority than the upper alarm.
Hysteresis	If set, this parameter is the numerical value to be considered as hysteresis to be applied on all levels for correct return without immediately raising an alarm or attention.
VO1	Expression to convert the acquired measure, after being processed by the processing formula, into a voltage value expressed in mV in the range 0 – 2500mV. Resulting value is applied to the analog output voltage VO1. If the expression is empty, the analog output is not used. ³
VO2	Expression to convert the acquired measure, after being processed by the processing formula, into a voltage value expressed in mV in the range 0 – 2500mV. Resulting value is applied to the analog output voltage VO2. If the expression is empty, the analog output is not used. ³
IO1	Expression to convert the acquired measure, after being processed by the processing formula, into a current value expressed in mA in the range 0 – 20mA. Resulting value is applied to the analog output current IO1. If the expression is empty, the analog output is not used. ³
IO2	Expression to convert the acquired measure, after being processed by the processing formula, into a current value expressed in mA in the range 0 – 20mA. Resulting value is

applied to the analog output current IO2. If the expression is empty, the analog output is not used.³

- DO1** Specifies if digital output DO1 is enabled and the activation condition (warning or alarm). If set to 1 (warning), DO1 is activated if measurement status is warning or alarm. If set to 2 (alarm), DO1 is activated if measurement status is alarm. If set to 0, DO1 is not enabled.³
- DO2** Specifies if digital output DO2 is enabled and the activation condition (warning or alarm). If set to 1 (warning), DO2 is activated if measurement status is warning or alarm. If set to 2 (alarm), DO2 is activated if measurement status is alarm. If set to 0, DO2 is not enabled.³
- DO3** Specifies if digital output DO3 is enabled and the activation condition (warning or alarm). If set to 1 (warning), DO3 is activated if measurement status is warning or alarm. If set to 2 (alarm), DO3 is activated if measurement status is alarm. If set to 0, DO3 is not enabled.³

2.2.2.2 Digital phase

This phase describes sensor data connected to a digital input.

This phase is characterised by the following operating parameters:

- MeasureID** Measurement identification. This number is unique and will be used in the recording of data.
- Specific** This parameter allows to assign to this sensor a specific trigonometric meaning. It signals if this sensor is normal, or a wind direction or speed. During trigonometric calculations it allows to correctly match the two vector components.
- PhysicalID** Address of the sensor connected to the digital channel. Allows to choose between the 3 digital input channels.
- ChannelType** Allows to define which type of processing to do on the input, such as frequency, period, count, duration, duty cycle or simply a sampling.
- nDec** With how many decimals the final stored number must be seen and truncated.
- Supply** Allows to define whether the input must be considered opto-isolated or if a pull-up power supply must be provided.
- Formula** It is possible to set a calculation formula. The determined value is identified by M0.

The wind sensors can record three values, vector, scalar and gust, as specified in the job, so “MeasurementID” is used as a starting point in the identifier to be used in the data, as follows.

- Vector MeasurementID used
- Scalar MeasurementID+1 used
- Gust MeasurementID+1 used.

Furthermore, each sensor phase has matched the following “Threshold parameters”:

- LimMax** If set, this parameter is the maximum numerical value for the number to be considered valid.
- LimMin** If set, this parameter is the minimum numerical value for the number to be considered valid.
- AllSup** If set, this parameter is the numerical value to be considered as an upper alarm level.
- AttSup** If set, this parameter is the numerical value to be considered as a higher level of attention. Has lower priority than the upper and lower alarm.
- AttInf** If set, this parameter is the numerical value to be considered as a lower level of attention. Has lower priority than the upper and lower alarm and the higher attention level.

AllInf	If set, this parameter is the numerical value to be considered as a lower alarm level. Has lower priority than the upper alarm.
Hysteresis	If set, this parameter is the numerical value to be considered as hysteresis to be applied on all levels for correct return without immediately raising an alarm or attention.
VO1	Expression to convert the acquired measure, after being processed by the processing formula, into a voltage value expressed in mV in the range 0 – 2500mV. Resulting value is applied to the analog output voltage VO1. If the expression is empty, the analog output is not used. ³
VO2	Expression to convert the acquired measure, after being processed by the processing formula, into a voltage value expressed in mV in the range 0 – 2500mV. Resulting value is applied to the analog output voltage VO2. If the expression is empty, the analog output is not used. ³
IO1	Expression to convert the acquired measure, after being processed by the processing formula, into a current value expressed in mA in the range 0 – 20mA. Resulting value is applied to the analog output current IO1. If the expression is empty, the analog output is not used. ³
IO2	Expression to convert the acquired measure, after being processed by the processing formula, into a current value expressed in mA in the range 0 – 20mA. Resulting value is applied to the analog output current IO2. If the expression is empty, the analog output is not used. ³
DO1	Specifies if digital output DO1 is enabled and the activation condition (warning or alarm). If set to 1 (warning), DO1 is activated if measurement status is warning or alarm. If set to 2 (alarm), DO1 is activated if measurement status is alarm. If set to 0, DO1 is not enabled. ³
DO2	Specifies if digital output DO2 is enabled and the activation condition (warning or alarm). If set to 1 (warning), DO2 is activated if measurement status is warning or alarm. If set to 2 (alarm), DO2 is activated if measurement status is alarm. If set to 0, DO2 is not enabled. ³
DO3	Specifies if digital output DO3 is enabled and the activation condition (warning or alarm). If set to 1 (warning), DO3 is activated if measurement status is warning or alarm. If set to 2 (alarm), DO3 is activated if measurement status is alarm. If set to 0, DO3 is not enabled. ³

2.2.2.3 Internal phase

This phase describes an internal sensor datum, such as diagnostic ones.

This phase is characterised by the following operating parameters:

MeasureID	Measurement identification. This number is unique and will be used in the recording of data.
PhysicalID	Address of the sensor connected to the internal channel. Available measures are: battery voltage (25), current consumption (26), photovoltaic voltage (27), charge current (28), board temperature (29), modem signal quality (30) ⁵ .
nDec	With how many decimals the final stored number must be seen and truncated.
Formula	It is possible to set a calculation formula. The determined value is identified by M0.

Each sensor phase has matched the following “Threshold parameters”:

LimMax	If set, this parameter is the maximum numerical value for the number to be considered valid.
LimMin	If set, this parameter is the minimum numerical value for the number to be considered valid.

⁵ Measure of modem signal quality (RSSI-Receive Signal Strength Indicator) is available from fw version 0.24.3

AllSup	If set, this parameter is the numerical value to be considered as an upper alarm level.
AttSup	If set, this parameter is the numerical value to be considered as a higher level of attention. Has lower priority than the upper and lower alarm.
AttInf	If set, this parameter is the numerical value to be considered as a lower level of attention. Has lower priority than the upper and lower alarm and the higher attention level.
AllInf	If set, this parameter is the numerical value to be considered as a lower alarm level. Has lower priority than the upper alarm.
Hysteresis	If set, this parameter is the numerical value to be considered as hysteresis to be applied on all levels for correct return without immediately raising an alarm or attention.
VO1	Expression to convert the acquired measure, after being processed by the processing formula, into a voltage value expressed in mV in the range 0 – 2500mV. Resulting value is applied to the analog output voltage VO1. If the expression is empty, the analog output is not used. ³
VO2	Expression to convert the acquired measure, after being processed by the processing formula, into a voltage value expressed in mV in the range 0 – 2500mV. Resulting value is applied to the analog output voltage VO2. If the expression is empty, the analog output is not used. ³
IO1	Expression to convert the acquired measure, after being processed by the processing formula, into a current value expressed in mA in the range 0 – 20mA. Resulting value is applied to the analog output current IO1. If the expression is empty, the analog output is not used. ³
IO2	Expression to convert the acquired measure, after being processed by the processing formula, into a current value expressed in mA in the range 0 – 20mA. Resulting value is applied to the analog output current IO2. If the expression is empty, the analog output is not used. ³
DO1	Specifies if digital output DO1 is enabled and the activation condition (warning or alarm). If set to 1 (warning), DO1 is activated if measurement status is warning or alarm. If set to 2 (alarm), DO1 is activated if measurement status is alarm. If set to 0, DO1 is not enabled. ³
DO2	Specifies if digital output DO2 is enabled and the activation condition (warning or alarm). If set to 1 (warning), DO2 is activated if measurement status is warning or alarm. If set to 2 (alarm), DO2 is activated if measurement status is alarm. If set to 0, DO2 is not enabled. ³
DO3	Specifies if digital output DO3 is enabled and the activation condition (warning or alarm). If set to 1 (warning), DO3 is activated if measurement status is warning or alarm. If set to 2 (alarm), DO3 is activated if measurement status is alarm. If set to 0, DO3 is not enabled. ³

2.2.3 Acquisition job from rain gauge

This job allows to acquire only the type of rain gauge sensor. It is unique in that the calculation is quite complex and it is not possible to have more than one connected to the same control unit.

The rain gauge sensor is of a titling tray type and has as its input a single digital signal that detects the tilting of the rocker. Two types of calculations are possible: rainfall and intensity of rainfall. To measure the accumulation, it is possible to periodically record continuous accumulation and rainfall. To measure intensity, the value is the average value of intensity per minute expressed hourly. The cumulative values can be recorded with a settable interval, while the intensities are compulsorily per minute.

This job is characterised by the following operating parameters:

MeasureID	Measurement identifier(s) used in data recording. You need to define two numbers separated by a comma. They identify cumulative rainfall and rainfall intensity respectively. These numbers must be unique.
DTR	Delta T recording in seconds of cumulated rainfall. Intensity is automatically per minute.
MskElab	This parameter allows to determine which calculations must be performed if possible (for example: cumulated, rainfall and rainfall intensity).
Volume	Volume of the rocker in cm ³ .
Area	Area of the collector mouth in cm ² .
Resolution	Resolution at each tilt in mm.
A[5]	The constants of the polynomial which allows to obtain the measurement error from the intensity of rainfall measured: $e[\%] = A_4 * I_m^4 + A_3 * I_m^3 + A_2 * I_m^2 + A_1 * I_m + A_0$.

The correction formula allows to calculate the true intensity of rainfall and therefore correct the intrinsic measurement error.

It is possible to set "Threshold parameters" and activate an alarm for this sensor as well. The management is similar to the "Pluviometric possibility curves, see dedicated appendix.

Attention1H	If set, this parameter is the maximum value considered as Caution of accumulated rain in the last hour;
Attention3H	If set, this parameter is the maximum value considered as Caution of accumulated rain in the last 3 hours;
Attention6H	If set, this parameter is the maximum value considered as Caution of accumulated rain in the last 6 hours;
Attention12H	If set, this parameter is the maximum value considered as Caution of accumulated rain in the last 12 hours;
Attention24H	If set, this parameter is the maximum value considered as Caution of accumulated rain in the last 24 hours;
Alarm1H	If set, this parameter is the maximum value considered as Cumulative Rain Alarm in the Last Hour;
Alarm3H	If set, this parameter is the maximum value considered as Cumulative Rain Alarm in theLast 3 hours;
Alarm6H	If set, this parameter is the maximum value considered as Cumulative Rain Alarm in the last 6 hours;
Alarm12H	If set, this parameter is the maximum value considered as Cumulative Rain Alarm in the last 12 hours;
Alarm24H	If set, this parameter is the maximum value considered as Cumulative Rain Alarm in the last 24 hours.

2.2.4 Acquisition job from Modbus sensor with start measurement command⁶

This job allows to acquire data through RS232 and RS485 serial port from a Modbus based sensor that requires a start measurement command and one or more subsequent commands to read the measures. The job is defined to acquire data from a single sensor as the sensor address, serial port parameters, sampling time, processing time and Modbus command to be sent before reading the measurements are specified.

Below are the configuration parameters. These fields are associated to all phases related to an acquisition job from Modbus sensor.

DTC	Sampling interval in seconds, i.e. the time interval between initiating each execution of the job to read one or more measures;
OffsetT	How many seconds before sampling time to send start measurement command, that is the start measurement command is sent OffsetT seconds earlier than subsequent acquisition commands. This parameter allows to adjust the timing between starting of the measurement and reading of the acquired data;
Address	Sensor modbus address (1-247);
FN	Modbus function code of the start measurement command, supported functions are: Write Single Register (6) and Write Multiple Registers (16);
Register	Address of the register to be written if function code is Write Single Register, address of the first register to be written if function code is Write Multiple Registers (in the latter case nRegister parameter defines the number of registres);
nRegister	Number of registers to be written (only for Write Multiple Registers function);
Values	Value(s) to be written in the register (function 6) or in the registers (function 16), in case of multiple registers inserted values must be separated by comma;
DTR	Recording interval in seconds, i.e. the time interval between each recording in memory of the processed data (DTC must be a submultiple of DTR);
Validity	A percentage from 0 to 100 that determines how much valid data must be acquired to obtain valid processing data;
MskElab	It determines which calculations must be performed at the end of the recording interval, specified in detail below;
COM	Serial port used: COM1 (RS232/485), COM2 (RS232), COM3 (RS485). Two jobs sharing the same port are executed one after the other;
Baud rate	Speed of communication over the serial port, from 1200 to 115200;
nBit	Number of bits: 7 or 8.
Parity	Parity to be used: none, even or odd.
nStop	Number of stop bits: 1, 1.5 or 2.
Timeout	Maximum waiting time for the sensor response in milliseconds, at the end of this time the job performs other attempts based on the nRetry value;
nRetry	Maximum number of attempts for start measurement command and for each phase.
Tsupply	Power pre-ignition time. All serial ports but COM1 have a power supply output. This parameter defines how many seconds before sending of the start measurement command

⁶ From fw version 0.22.20

power supply should be turned on. After acquisition is completed power supply is switched off. If set to zero, power supply will always be on. If multiple jobs are defined on the same serial port, care must be taken and for example set the power supply always on;

This job is scanned every second. Power on time is checked first (if defined in configuration, i.e. Tsupply not zero). Then the job starts the measurements and after OffsetT seconds, if the start commands is successful, the acquisition of the measures is executed. The job temporarily stores partial results and at the end of the recording interval (DTR) it computes the processing data specified by MskElab.

The elaboration mask determines which data are computed for all sensors by the job:

Last	last data acquired
Average	mathematical average
Maximum	maximum value of samples acquired
Minimum	minimum value of samples acquired
DevST	standard deviation of samples acquired
Vector	for wind sensors only, the recording of vector trigonometry values
Scalar	for wind sensors only, the recording of scalar trigonometry values
Gust	for wind sensors only, the recording of gust values.

This elaboration mask is also used in other jobs.

It is possible to define only one type of phase that represents the Modbus measure acquired from the sensor.

2.2.4.1 Modbus measure phase

Modbus measure phase describes a single measure acquired from a Modbus based sensor. Configuration parameters of this phase are listed below.

MeasureID	Measurement identification. This number is unique and will be used in the data recording;
Specific	It assigns to this measure a specific trigonometric meaning. It specifies if this measure is a normal data, a wind direction data or a wind speed data. It allows to correctly match the two vector components when trigonometric calculations are performed.
FN	Modbus function code of the acquisition command, supported functions are: Read Holding Registers (3) and Read Input Registers (4);
StartRegister	Address of the first register to be read;
nRegister	Number of registers requested;
DataType	It defines the data type (Boolean, 2-byte or 4-byte integer, floating point data) and the way the data is read;
Register	Register where the data to be read is stored or starting register in case of 4-byte data (it must be in the range defined by StartRegister and nRegister). If other phases are configured with the same function code and with a register that falls in the range defined by the starting register (StartRegister) and the number of registers requested (nRegister), these phases will be completed with a single acquisition command, whose response will contain all the measures of these phases.
nDec	Number of decimal digits with which the data is represented.
Formula	Processing formula applied to the acquired data (in the expression it is identified by M0).

Wind sensors can record three values (vector, scalar and gust) as specified in the job, so MeasureID must contain three comma separated codes, respectively vector, scalar and gust.

Furthermore, the following “Threshold parameters” are defined for each sensor phase:

LimMax	If set, it represents the maximum value beyond which the acquired value is considered invalid;
LimMin	If set, it represents the minimum value beyond which the acquired value is considered invalid;
AllSup	If set, it represents the value beyond which the acquired value is considered in upper alarm state;
AttSup	If set, it represents the value beyond which the acquired value is considered in upper warning state. It has a lower priority than the upper alarm and lower alarm states;
AttInf	If set, it represents the value beyond which the acquired value is considered in lower warning state. It has a lower priority than the upper alarm, lower alarm and upper warning states;
AllInf	If set, it represents the value beyond which the acquired value is considered in lower alarm state. It has a lower priority than the lower alarm state;
Hysteresis	If set, it represents the hysteresis applied to all thresholds to avoid immediate states change around the thresholds.
VO1	Expression to convert the acquired measure, after being processed by the processing formula, into a voltage value expressed in mV in the range 0 – 2500mV. Resulting value is applied to the analog output voltage VO1. If the expression is empty, the analog output is not used. ³
VO2	Expression to convert the acquired measure, after being processed by the processing formula, into a voltage value expressed in mV in the range 0 – 2500mV. Resulting value is applied to the analog output voltage VO2. If the expression is empty, the analog output is not used. ³
IO1	Expression to convert the acquired measure, after being processed by the processing formula, into a current value expressed in mA in the range 0 – 20mA. Resulting value is applied to the analog output current IO1. If the expression is empty, the analog output is not used. ³
IO2	Expression to convert the acquired measure, after being processed by the processing formula, into a current value expressed in mA in the range 0 – 20mA. Resulting value is applied to the analog output current IO2. If the expression is empty, the analog output is not used. ³
DO1	Specifies if digital output DO1 is enabled and the activation condition (warning or alarm). If set to 1 (warning), DO1 is activated if measurement status is warning or alarm. If set to 2 (alarm), DO1 is activated if measurement status is alarm. If set to 0, DO1 is not enabled. ³
DO2	Specifies if digital output DO2 is enabled and the activation condition (warning or alarm). If set to 1 (warning), DO2 is activated if measurement status is warning or alarm. If set to 2 (alarm), DO2 is activated if measurement status is alarm. If set to 0, DO2 is not enabled. ³
DO3	Specifies if digital output DO3 is enabled and the activation condition (warning or alarm). If set to 1 (warning), DO3 is activated if measurement status is warning or alarm. If set to 2 (alarm), DO3 is activated if measurement status is alarm. If set to 0, DO3 is not enabled. ³

2.3 *Transmission activity*

The transmission activity has the task of sending data to the services. The data is taken from the internal memory, both temporary and permanent. About ten jobs can be performed, from the following options:

1. FTP server transmission job
2. SMS transmission job
3. Satellite transmission job

2.3.1 *FTP server transmission job*

This job allows to transmit data to a certain amount of FTP servers, which are all operated serially.

This job is characterised by the following operating parameters, valid for all phases defined below:

DTNormal	Delta T of data transmission in seconds, i.e. how often to activate the job and call all phases.
DTAttention	Delta T of data transmission in seconds, to be used if a sensor is in attention state.
DTAlarm	Delta T of data transmission in seconds, to be used if a sensor is in alarm state. Alarm is more important than attention, which in turn is more important than normal.
OffsetT	Offset in seconds on all previous Delta Ts, which serves to produce the necessary delay to acquire data.

This job uses the internal UMTS/LTE modem. When this job needs to transmit data it requests the transmission task to grant access to the modem. The modem is then turned on, correctly initialised and made available to the job that can grant permission for data transmission at each phase. When all phases have completed their tasks, the modem is released and made available for other jobs which in the meantime may have reserved the same resource. When there is no job to perform, the modem is turned off to reduce energy consumption.

These are the possible phases:

2.3.1.1 *FTP SERVER phase*

This phase describes an FTP server and allows to send outgoing data which was sent and received on this server.

This phase is characterised by the following operating parameters:

Type	Allows to differentiate the format of the data sent: 1= Siap track + dynamic Micros, 2 = ASCII, 3 = Full binary and 4 = Rain track (specific for the order 210077);
Host	IP address or name of server to contact
Port	Port number to use
User	User to use in the connection
Password	Password string to be used along with the user
Mode	Transfer type, active or passive
Prefix	Prefix of the name of the file to be used for the transfer
Path	Name of the directory where the file will be inserted
nRec	Maximum number of records to send for each send.

2.3.2 SMS transmission job

This job allows to receive SMS messages and send alarms in SMS format. Each sensor is associated with a certain number of thresholds. Each time a measurement is taken, the numeric value is compared with these thresholds and the alarm state is calculated. If the alarm state has changed, an alarm is generated, i.e. this job is activated which has the task of sending a notification to all SMS terminal phases.

In any case, the arrival of SMS messages is checked periodically and, if possible, the command is executed.

This job is characterised by the following operating parameters, valid for all the phases defined below:

- DTNormal** Delta T of data transmission in seconds, i.e. how often to activate the job.
- DTAttention** Delta T of data transmission in seconds, to be used if a sensor is in attention state.
- DTAlarm** Delta T of data transmission in seconds, to be used if a sensor is in alarm state. Alarm is more important than attention, which in turn is more important than normal.

This job uses the internal UMTS/LTE modem. When this job needs to transmit data it requests the transmission task to grant access to the modem. The modem is then turned on, correctly initialised and made available to the job that can grant permission for data transmission at each phase. When all phases have completed their tasks, the modem is released and made available for other jobs which in the meantime may have reserved the same resource. When there is no job to perform, the modem is turned off to reduce energy consumption.

These are the possible phases:

2.3.2.1 SMS terminal phase

This phase describes an SMS terminal. When the control unit detects a change in state of a sensor, for example attention and alarm, it sends a message to all these terminals. Moreover, all these terminals are enabled to send messages to the control unit.

This phase is characterised by the following operating parameters:

- MskAbil** Allows to differentiate the behaviour of the terminal.
- Number** Telephone number. If the first character is '+', the number is an international number with the country code. Alternatively, it is a national number.

2.3.3 Satellite transmission job

This job allows the transmission of data via a satellite device.

This job is characterised by the following operating parameters, valid for all the phases defined below:

- DTNormal** Delta T of data transmission in seconds, i.e. how often to activate the job.
- DTAttention** Delta T of data transmission in seconds, to be used if a sensor is in attention state.
- DTAlarm** Delta T of data transmission in seconds, to be used if a sensor is in alarm state. Alarm is more important than attention, which in turn is more important than normal.
- OffsetT** Offset in seconds on all previous Delta Ts, which serves to produce the necessary delay to acquire data.
- Type** Determines the type of satellite transmission: Iridium, Goes or Meteosat.
- Mode** Send format: binary, pseudobinary, binary, etc.
- ListID** String of maximum 50 characters which defines the list of sensors to be sent. Numbers are separated by a comma.

This job uses a serial channel that must be defined previously. The parameter type is the same, defined as a serial channel.

2.3.4 Radio transmission work

This work allows data to be transmitted via a UHF radio apparatus.

This work is characterized by the following parameters of operation:

DTNormal	DT of data transmission in seconds, that is, every time to activate the work;
OffsetT	Offset in secondi su tutti i precedenti delta T, it serves to delay as much as it allows to acquire data;
LengthT	How long must the apparatus remain to answer radio calls, to have the apparatus always available set this value equal to the DT transmission time;
Mode	Sending format, dynamic S+M, ASCII, etc.;
Tsynch	Maximum phase shift time before updating the datalogger time;
Flag	Internal Number flag to control the shutdown of the radio apparatus (Polaris).

This work uses a serial channel that must be previously defined. The serial channel type parameter must be set to UHF.

2.4 Description of signal LEDs

There are three types of signal LEDs:

- Status LED: signals the activity state of the data logger. When the LED is on the data logger is carrying out scheduled operations, while when it is off there are no operation in progress and microcontroller is in a low-power state. Therefore, the status LED implicitly indicates the consumption of the data logger.
- COM LEDs: there are two LEDs for each serial port, the blue one indicates that a transmission (TX) is in progress and the red one indicates that a reception is in progress (RX).
- xG Modem LEDs: ON LED (green light) indicates the status of the power supply to the modem (on when modem is powered), STS LED (red light) indicates the operating status of the modem (on during communication).



3 Wiring

This chapter describes how to connect the datalogger and the relevant parameters for proper operation.

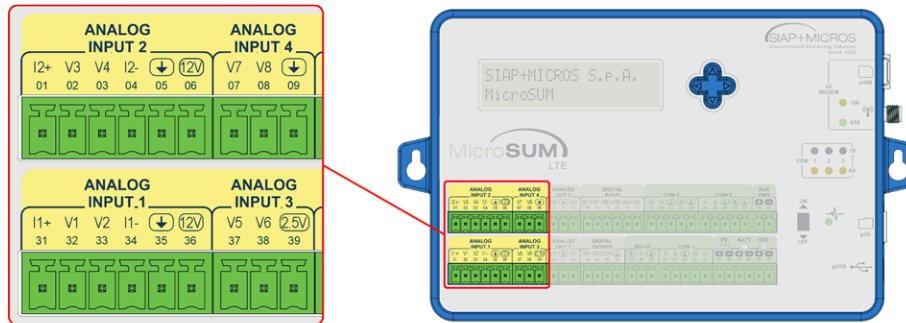
3.1 Analog inputs



Single-ended analog inputs	<p>There are 8 single-ended analog inputs.</p> <p>AnSing V1 (pin 32) AnSing V2 (pin 33) AnSing V3 (pin 02) AnSing V4 (pin 03) AnSing V5 (pin 37) AnSing V6 (pin 38) AnSing V7 (pin 07) AnSing V8 (pin 08)</p> <p>Operating range from 0V to +2.5V, referred to ground.</p> <p>Three grounds can be used (symbol ) (pin 05, 09 and 35), The value M0 obtained and usable as an input in the Formula, is expressed in μV.</p>
Differential analog inputs	<p>There are 4 differential analog inputs:</p> <p>AnDiff V1 (pin 32) - V2 (pin 33) AnDiff V3 (pin 02) - V4 (pin 03) AnDiff V5 (pin 37) - V6 (pin 38) AnDiff V7 (pin 07) - V8 (pin 08)</p> <p>Operating range from -2.5V to +2,5V, not referred to ground.</p> <p>The value M0 obtained and usable as an input in the formula, is expressed in μV.</p>
PT100	<p>There are 2 four-wire PT100s. Resistance is automatically supplied for the time strictly necessary to perform the measurement. Ix+ e Ix- are the supply points, while Vx+ e Vx- are the measuring points.</p> <p>PT100 1: I1+ (pin 31) and I1- (pin 34) power supply, V1 (pin 32) and V2 (pin 33) measurement.</p> <p>PT100 2: I1+ (pin 01) and I1- (pin 04) power supply, V1 (pin 02) and V2 (pin 03) measurement.</p> <p>The value M0 obtained and usable as an input in the formula, is expressed in Ohm.</p> <p>The formula used to obtain the temperature in degrees C is:</p> $T[^\circ C] = (9.847E - 4) * R^2 + 2.362 * R - 246.04$

Power supplies	<p>There are two 12V power outputs, maximum 1.5A, (symbol ). Use is configured in the job which groups all the connected phases and it is possible to define the time in seconds for activation before measuring. By inserting the number zero, power supply is constant. This supply is generated by a buck-boost transformer, meaning it is independent from the real value of the power supply.</p> <p>There is also a maximum of  150mA to power any potentiometers or provide references.</p>
-----------------------	--

Analog inputs are equipped with:

- Electrostatic discharge protection circuit up to 30kV with peak power at 330W (8/20µs).
- 40A current limit with resettable fuse protection.

2.5V power supply is equipped with electrostatic discharge protection circuit up to 30kV with peak power at 330W (8/20µs).

On each single-ended or differential analog input a filter for the duration of the basic measurement can be set, which can be from 0.2ms to 400ms. The higher the time, the more precise and filtered the measurement, but acquisition is slower. It is also possible to enable the buffered input, i.e. insert an amplifier which increases the impedance value, but slightly alters the measurement.

3.2 Digital inputs

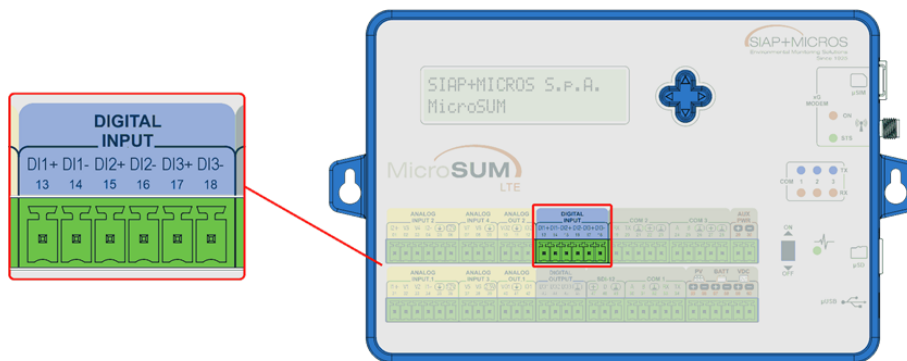

The digital inputs are opto-isolated:

Opto-isolated inputs	<p>There are 3 digital opto-isolated inputs:</p> <p>Digital 1 (DI1+ pin 13 and DI1- 14) Digital 2 (DI2+ pin 15 and DI2- 16) Digital 3 (DI3+ pin 17 and DI3- 18)</p> <p>A signal with a minimum voltage of 5V must be supplied to these inputs</p>
Contact inputs	<p>The same inputs can be treated as normal contacts. In this case it is necessary to enable a PULL-UP of around 12V internally, which will be supplied to the DIx+ signal, and use the DIx- signal towards ground (symbol  pin 46):</p>

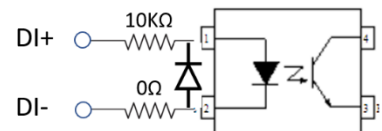

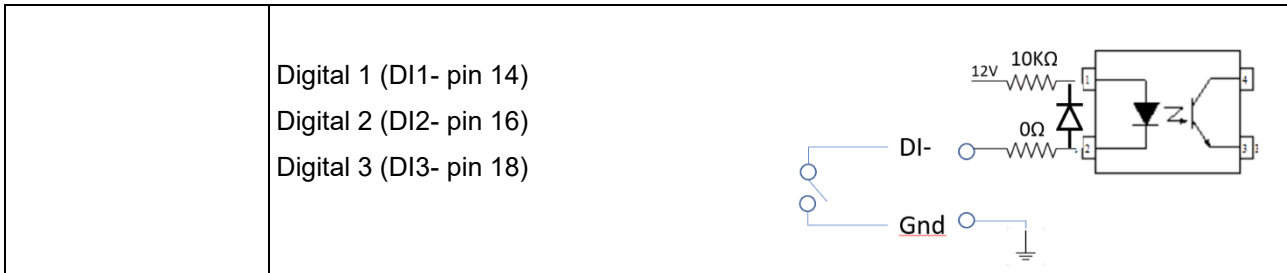

Digital inputs are equipped with electrostatic discharge protection circuit up to 30kV with peak power at 160W (8/20µs).

The Micro SUM measures the time instants of these front inputs. At the DTC time partial calculations are performed and at the DTR time the final calculations are made:

Frequency	Average frequency expressed in Hz with 0.1Hz resolution. Average frequency is calculated at the DTC. Average, minimum, maximum and standard deviation can be recorded at the DTR. If there are no transitions in the DTC, the frequency calculated is 0.
Period	Average period expressed in seconds with 0.1s resolution. The average period is calculated at the DTC. Average, minimum, maximum and standard deviation can be recorded at the DTR. If there are no transitions in the DTC, the period is infinite and considered invalid, and is therefore not part of the calculation of the average.
Count	Number of cycles with half-cycle resolution. The event count is recorded at the DTR. The DTC becomes effectively useless.
Lenght 0	Duration of level 0 expressed in seconds with 0.1s resolution. The total duration is recorded at the DTR. If there are no transitions in the DTC, the duration is high and considered invalid, and is therefore not part of the calculation of the total duration.
Lenght 1	Duration of level 1 expressed in seconds with 0.1s resolution. The total duration is recorded at the DTR.
DutyCycle 0	Level 0 average duty cycle expressed as a percentage with 0.1% resolution. The duty cycle of value 1 is calculated at the DTC. Average, minimum, maximum and standard deviation can be recorded at the DTR. If there are no transitions in the DTC, the duty cycle is unknown and considered invalid, and is therefore not part of the calculation of the average.
DutyCycle 1	Level 1 average duty cycle expressed as a percentage with 0.1% resolution. The duty cycle of value 0 is calculated at the DTC. Average, minimum, maximum and standard deviation can be recorded at the DTR. If there are no transitions in the DTC, the duty cycle is unknown and considered invalid, and is therefore not part of the calculation of the average.

Sample 0	The logic state 0 is sampled at the DTC and assigned the DTC value for the whole duration of sampling. It is therefore expressed in seconds. The count of total durations is recorded at the DTR.
Sample 1	The logic state 1 is sampled at the DTC and assigned the DTC value for the whole duration of sampling. It is therefore expressed in seconds. The count of total durations is recorded at the DTR.
Logical	The logic state is sampled at the DTC. Average, minimum, maximum and standard deviation can be recorded at the DTR.

3.3 Analog outputs

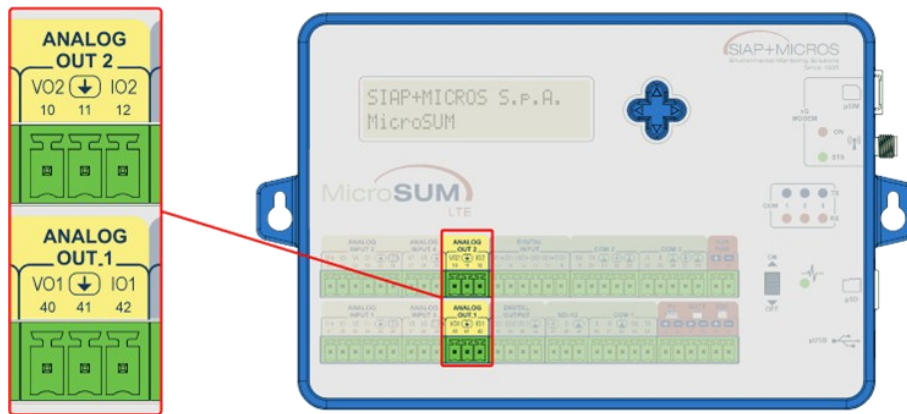

MicroSUM is equipped with four analog outputs, two output voltages (pins 10 and 40) in the range 0 – 2.5V and two output currents (pins 12 and 42) in the range 0 – 20mA. Symbol  (pins 11 and 41) indicates analog ground. Output voltages are equipped with electrostatic discharge protection circuit up to 30kV with peak power at 330W (8/20µs), while output currents are equipped with electrostatic discharge protection circuit up to 30kV with peak power at 200W (8/20µs).

As described in Chapter 102, each measurement value can be converted, through a conversion formula, into a voltage or current value that is applied to a selected analog output. This allows you to generate voltage and current values proportional to the measurement value.³

3.4 Digital outputs

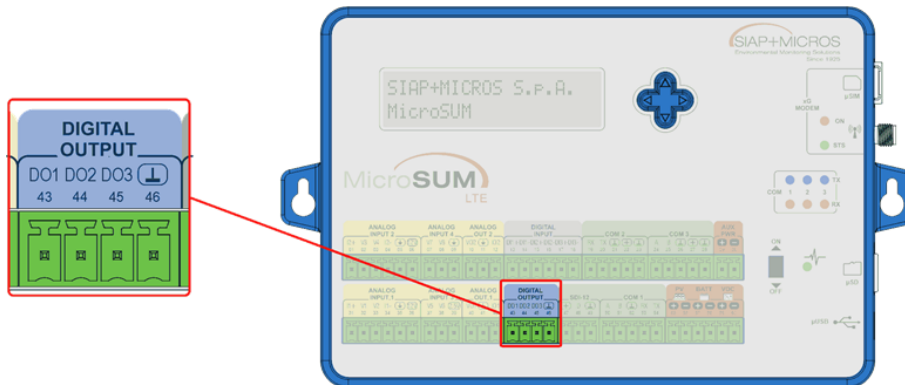

Digital outputs (pins 43, 44 and 45) are equipped with:

- Electrostatic discharge protection circuit up to 15kV with peak power at 350W (8/20 μ s).
- 40A current limit with resettable fuse protection.

Pin 46  indicates digital ground.







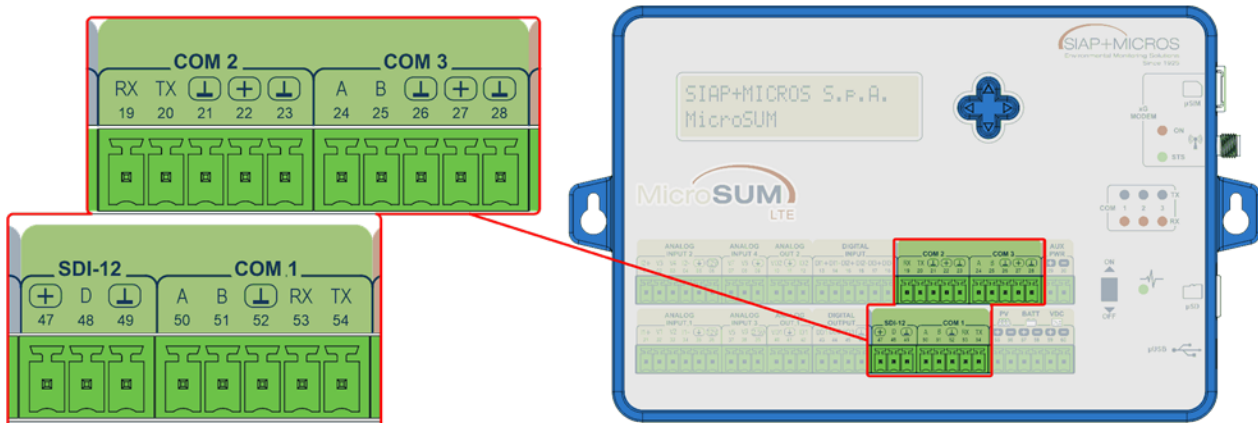

As described in Chapter 102, digital outputs can be driven according to measurement status. Activation conditions are:

- Warning: digital output is activated if measurement status is warning (upper or lower) or alarm (upper or lower).
- Alarm: digital output is activated if measurement status is alarm (upper or lower).

Measurement status is defined according to threshold and hysteresis values. If measurement value goes back to a normal state, the digital output is disabled. Bear in mind that warning state precedes alarm state, therefore it is a less serious condition than the alarm state (see Chapter 12.1).³

3.5 Serial ports



COM1	This port can be either RS232 or RS485, but not both. RS232 (TX pin 54, RX pin 53 and GND  pin 52) RS485 (A pin 50 and B pin 51)
COM2	RS232 serial port which can provide power supply on request. RS232 (TX pin 20, RX pin 19 and GND  pin 21) Power Supply Vbat (positive +12V  pin 22 and ground  pin 23)
COM3	RS485 serial port which can provide power supply on request. RS485 (A pin 24 and B pin 25) Power Supply Vbat (positive +12V  pin 27 and ground  pin 28)
SDI-12	SDI-12 serial port, a two-way data line that can provide power supply on request. Positive +12V  pin 47, signal D pin 48 and ground  pin 49.

RS485 serial ports are equipped with electrostatic discharge protection circuit up to 30kV with peak power at 600W (8/20µs). SDI-12 serial port is supplied with electrostatic discharge protection circuit up to 30kV with peak power at 1000W (8/20µs).

When a serial port acquisition job is running, power supply can be both permanent and temporary.

When using a serial port with protocol, the power supply is automatically inserted.

3.6 Power supplies

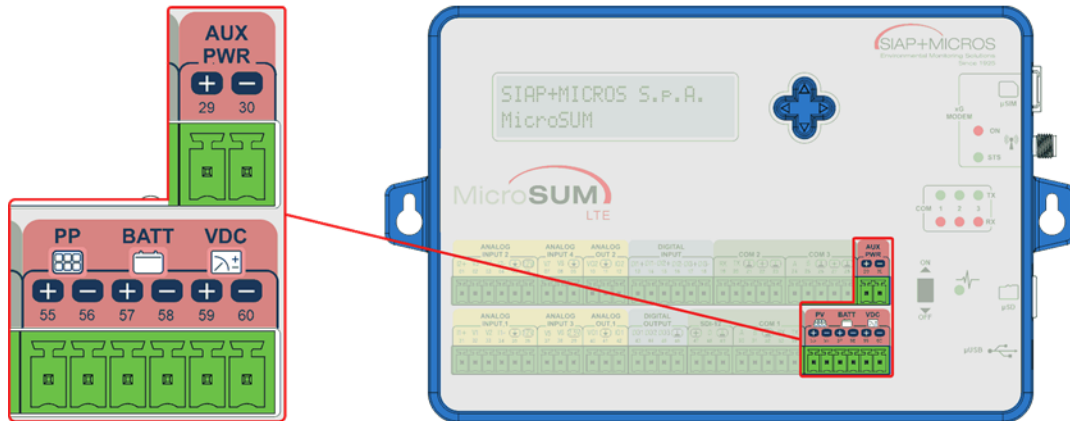

Ingresso alimentazione	Simbolo	Pin
Photovoltaic panel 24V _{MAX} $\overline{\text{---}}$ 5.5A	PP 	Positive + (pin 55) Negative - (pin 56)
Rechargeable lead-acid battery 12V $\overline{\text{---}}$ 10A	BATT 	Positive + (pin 57) Negative - (pin 58)
External power supply 10.5V ÷ 15V $\overline{\text{---}}$ 10A	VDC 	Positive + (pin 59) Negative - (pin 60)
Auxiliary power supply 5.5V ÷ 15V $\overline{\text{---}}$ 10A	AUX PWR	Positive + (pin 29) Negative - (pin 30)

Usually a lead-acid battery and a photovoltaic panel are used to power the data logger. Wiring instructions are explained below:

1. Connect lead-acid battery to BATT pins 57 and 58.
2. Pay attention to the polarity of battery terminals: pin 57 must be connected to the positive terminal and pin 58 to the negative terminal.
3. Connect photovoltaic panel to PP pins 55 and 56.
4. Pay attention to the polarity of photovoltaic panel terminals: pin 55 must be connected to the positive terminal and pin 56 to the negative terminal.
5. As an alternative to photovoltaic panel, an external power supply with 12VDC nominal voltage can be connected to VDC pins 59 and 60.
6. Turn on the data logger by moving the main switch to ON position.

The battery is recharged in two distinct phases, the first at constant current and the second at constant voltage. Maximum voltage is predetermined and temperature corrected. The solar panel supplies power to

the battery charger. Internally it is made to operate at the voltage that optimises power transfer. Control is automatic and occurs every 5 seconds. Battery charger is also equipped with a control to protect the lead-acid battery from deep discharge. In particular, if battery voltage drops below 10.5V the data logger is turned off to protect the battery. Battery charger remains operational and it will continue to charge the battery if solar radiation is detected. When battery voltage goes above 11.5V the data logger is turned on again.

The external power supply is actually parallel to the battery, so if used together with the battery it must be 13.8V. If a high voltage power supply is used and there is no solar panel, it is possible to supply power instead of the solar panel.

The auxiliary power supply is downstream and non-rechargeable lithium batteries can be used. If the system provides for simultaneous operation with a lead battery recharged by solar panel and an auxiliary battery, the latter must be at a lower voltage so that it can become operational only in the case of real need as a system back-up.

4 Examples of wiring with Siap+Micros sensors

Below are some examples of the wiring and configuration of the most common Siap+Micros sensors:

4.1 TTEP-N (PT100 temperature sensor)

The sensor is a small cabin which contains a 4-wire PT100 sensor. Possible wiring:

Connector 4 poles		Input Micro SUM
Pin 1 Red	I+	Analog Input 1 I1+ (pin 31)
Pin 2 White	V+	Analog Input 1 V1+ (pin 32)
Pin 3 Green	V-	Analog Input 1 V1- (pin 33)
Pin 4 Black	I-	Analog Input 1 I1- (pin 34)

The sensor element is a PT100 which is automatically powered during measuring. The datalogger measures and returns the resistance value that must be converted into degrees C with the formula:

$$\begin{aligned}
 A &= 0.0009847 \\
 B &= 2.362 \\
 C &= -246.04 \\
 T[^\circ\text{C}] &= A * R_{pt100}^2 + B * R_{pt100} + C
 \end{aligned}$$

Below is an example of how to programme the Micro SUM internal parameters:

Analog/Digital sensors	
Name	Sensor PT100
Enabled	Yes
Delta sampling time (sec)	3 seconds
Delta recording time (sec)	600 seconds = 10 minutes
Validity (%)	50%
Standard processing mask	2 = Average
Supply	None
Pre-ignition time (sec)	0
Analog	
Name	Temperature [oC]
Enabled	Yes
Measure identifier	(unique number)
Specific code	Normal
Physical address	PT100 1
Filter	3.1ms
Number of decimals	1
Formula	M0*M0*9.847e-4 + M0*2.362 -246.04

4.2 TTEPRH-S (MODBUS humidity temperature sensor)

The sensor is a cabin which contains an intelligent sensor that detects various environmental parameters. The sensor responds to the Modbus RTU protocol and directly provides the converted values. Possible wiring:

Connector 7 poles		Input Micro SUM
Pin 1 Red	A	COM3 A (pin 24)
Pin 2 White	B	COM3 B (pin 25)
Pin 6 Giallo	Vcc	COM3 + (pin 27)
Pin 7 Blu	GND	COM3 GND (pin 28)

Register 1-2 contains the air temperature value, while register 3-4 contains the humidity value. By making a single call to read four registers, a single request is made but the two values are obtained simultaneously.

Below is an example of how to programme the Micro SUM internal parameters:

Serial sensors	
Name	Modbus sensors
Enabled	Yes
Delta sampling time (sec)	3 seconds
Delta recording time (sec)	600 seconds = 10 minutes
Validity (%)	50%
Standard processing mask	2 = Average
Serial port	COM3
Port speed (bps)	9600
Number of data bits	8
Parity mode	None
Number of stop bits	1
Protocol	Modbus
Number of retry	3
Pre-ignition time (sec)	0 always on
Modbus sensor	
Name	Air Temperature [oC]
Enabled	Yes
Measure identifier	(unique number)
Specific code	Normal
Modbus address	3
Function code	Read Holding Registers
Starting address	1
Quantity registers	4
Type	Swapped Float
Measure address	1
Timeout (msec)	2000

Number of decimals	1
Formula	M0
Modbus sensor	
Name	Air Humidity [%]
Enabled	Yes
Measure identifier	(unique number)
Specific code	Normal
Modbus address	3
Function code	Read Holding Registers
Starting address	1
Quantity registers	4
Type	Swapped Float
Measure address	3
Timeout (msec)	2000
Number of decimals	0
Formula	M0

4.3 WINSON (MODBUS sonic anemometer)

The sensor detects air movement via three acoustic transducer receivers/transmitters. It is an intelligent sensor that continuously provides environmental values. The sensor responds to various protocols, including Modbus RTU. Possible cabling:

Connector 10 poles		Input Micro SUM
Pin 1 Brown	A	COM3 A (pin 24)
Pin 2 Red	B	COM3 B (pin 25)
Pin 9 White	Vcc	COM3 + (pin 27)
Pin 10 Black	GND	COM3 GND (pin 28)

Register 1-2 contains the wind speed value, while register 3-4 contains the wind direction value and register 5-6 contains the air temperature value. By making a single call to read six registers, a single request is made but the three values are obtained simultaneously.

Each direction and speed parameter has 3 possible registration values, those calculated as vector, scalar and gust. Therefore, the measure identifier identifies the first of 3 consecutive values that will be used.

Below is an example of how to programme the Micro SUM internal parameters:

Serial sensors	
Name	Winson sensor
Enabled	Yes
Delta sampling time (sec)	3 seconds
Delta recording time (sec)	600 seconds = 10 minutes
Validity (%)	50%
Standard processing mask	226 = 2(Average) + 32(Vector) + 64(Scalar) + 128(Gust)
Serial port	COM3

Port speed (bps)	9600
Number of data bits	8
Parity mode	None
Number of stop bits	1
Protocol	Modbus
Number of retry	3
Pre-ignition time (sec)	0 always on
Modbus sensor	
Name	Wind Speed [m/s]
Enabled	Yes
Measure identifier	(unique numbers) Vector, Scalar, Gust
Specific code	Wind speed
Modbus address	1
Function code	Read Holding Registers
Starting address	1
Quantity registers	6
Type	Swapped Float
Measure address	1
Timeout (msec)	200
Number of decimals	1
Formula	M0
Modbus sensor	
Name	Wind Direction [°GN]
Enabled	Yes
Measure identifier	(unique numbers) Vector, Scalar, Gust
Specific code	Wind direction
Modbus address	1
Function code	Read Holding Registers
Starting address	1
Quantity registers	6
Type	Swapped Float
Measure address	3
Timeout (msec)	200
Number of decimals	1
Formula	M0
Modbus sensor	
Name	Wind Temp [oC]
Enabled	Yes
Measure identifier	(unique number)

Specific code	Normal
Modbus address	1
Function code	Read Holding Registers
Starting address	1
Quantity registers	6
Type	Swapped Float
Measure address	5
Timeout (msec)	200
Number of decimals	1
Formula	M0

4.4 TBF (Leaf wetting)

The sensor is a simulation of a leaf and provides a simple closed contact if the surface is wet. Possible cabling:

Connector 4 poles		Input Micro SUM
Pin 1 Red 12V power	12V Power	Analog Input 2 12V (pin 06)
Pin 2 White contact	Contact	Digital Output GND (pin 46)
Pin 3 Green contact	Contact	Digital Input DI2- (pin 16)
Pin 4 Black GND	GND	Analog Input 2 GND (pin 05)

The sensor must be sampled periodically and if the contact is closed (wet leaf), the sampling rate in seconds is the value normally used. At the time of recording, the sum of seconds is stored, i.e. for how long the leaf was wet.

Below is an example of how to programme the Micro SUM internal parameters.

Analog/Digital sensors	
Name	TBF
Enabled	Yes
Delta sampling time (sec)	5 seconds
Delta recording time (sec)	1800 seconds = 30 minutes
Validity (%)	50%
Standard processing mask	2 = Average
Supply	Analog input 2
Pre-ignition time (sec)	0 always on
Digital	
Name	Wet leaf [s]
Enabled	Yes
Measure identifier	(unique number)
Specific code	Normal
Physical address	Digital 2

Type	Sample 0
Number of decimals	0
Pullup	Pullup
Formula	M0

4.5 TP (Tilting rain gauge)

The sensor is composed of a funnel to capture rain water which is directed to a tilting tank that weighs the water. Each tilt corresponds to a given level of rainfall that corresponds to the resolution of the instrument. With this datalogger it is possible to calculate both rainfall and rainfall intensity. The time definition of the latter is in minutes but it is expressed in mm/h, so the datalogger will always record this sensor every minute. At high intensity, all tilting rain gauges have an underestimation error that can be corrected by means of a programmable polynomial. There is only one connectable rain gauge and it must be connected to the first digital channel. The wiring is as follows:

Connector 7 poles		Input Micro SUM
Pin 1 Red	Contact	Digital Output GND (pin 46)
Pin 2 White	Contact	Digital Input DI1- (pin 14)

Below is an example of how to programme the Micro SUM internal parameters:

Rain gauge	
Name	Rain gauge
Enabled	Yes
Cumulate rain fall identifier	(unique number)
Cumulate and intensity rain fall identifiers	(unique numbers) Cumulate,Intensity
Delta recording time (sec)	1800 seconds = 30 minutes
Rain gauge processing mask	5 = 1(Cumulative rain) + 4(Rain intensity)
Tipping bucket volume	10
Catchment area	500
Resolution	0.2
A0	0
A1	0
A2	0
A3	0
A4	0

4.6 TVV e TDV (Anemometer)

The anemometer is composed of two distinct natural sensors, wind speed and wind direction. Possible wiring:

TVV Wind Speed		
Connector 4 poles		Input Micro SUM
Pin 1 Red	VDC (power)	Analog Input 1 12V (pin 36)

Pin 2 White	Out (open drain)	Digital Input DI2- (pin 16)
Pin 4 Black	Ground	Analog Input 1 GND (pin 35)

This paddlewheel sensor with three cups has an open-drain output in frequency. 3.3676 Hz corresponds to 1 m/s.

TDV		
Connector 7 poles		Input Micro SUM
Pin 6 Yellow	VDC (power)	Analog Input 1 12V (pin 36)
Pin 3 Green	Out (0-2 Vdc)	Analog Input 4 V8 (pin 08)
Pin 5 Orange	Out (Ground analog 0-2Vdc)	Analog Input 4 GND (pin 09)
Pin 7 Blu	Ground	Analog Input 1 GND (pin 35)

This windvane sensor with 0-2V output voltage corresponding to 0-360°, direction north.

Each direction and speed parameter has 3 possible registration values, those calculated as vector, scalar and gust. Therefore, the measure identifier identifies the first of 3 consecutive values that will be used.

Below is an example of how to programme the Micro SUM internal parameters:

Analog/Digital sensors	
Name	Natural wind
Enabled	Yes
Delta sampling time (sec)	3 seconds
Delta recording time (sec)	600 seconds = 10 minutes
Validity (%)	50%
Standard processing mask	224 = 32(Vector) + 64(Scalar) + 128(Gust)
Supply	Analog input 1
Pre-ignition time (sec)	0 always on
Digital	
Name	Wind speed [m/s]
Enabled	Yes
Measure identifier	(unique numbers) Vector, Scalar, Gust
Specific code	Wind speed
Physical address	Digital 2
Type	Frequency
Number of decimals	1
Pullup	Pullup
Formula	M0/3.36
Analog	
Name	Wind direction [°GN]
Enabled	Yes
Measure identifier	(unique numbers) Vector, Scalar, Gust
Specific code	Wind direction
Physical address	Analog single 8
Filter	3.1ms

Number of decimals	1
Formula	M0/1000000*180

4.7 TLRx-I (Level radar sensor)

The sensor is available in various configurations including the 4-20mA current output. In this version it is necessary to insert a 100 Ohm resistor on the datalogger terminal board. Possible wiring:

Cable 2 poles		Input Micro SUM
Red	VDC (power)	Analog Input 2 12V (pin 06)
Black	Out (4-20mA)	Analog Input 2 V3 (pin 02)
	Resistor 100 ohm	Analog Input 2 V3 (pin 02)
		Analog Input 2 GND (pin 05)

Below is an example of how to programme the Micro SUM internal parameters:

Analog/Digital sensors	
Name	Radar sensor
Enabled	Yes
Delta sampling time (sec)	300 seconds = 5 minutes
Delta recording time (sec)	1800 seconds = 30 minutes
Validity (%)	50%
Standard processing mask	2= Average
Supply	Analog input 2
Pre-ignition time (sec)	0 always on
Analog	
Name	Level [m]
Enabled	Yes
Measure identifier	(unique number)
Specific code	Normal
Physical address	Analog single 3
Filter	3.1ms
Number of decimals	2
Formula	$(M0*1e-6-0.4)/(1.6)*30$

A value between 4÷20mA applied to a 100Ω resistor is equivalent to a voltage between 0.4÷2.0V. The M0 value supplied by the analog output is expressed in μV, so $(M0*1e-6-0.4)/(1.6)$ is a number between 0-1. In the example it is multiplied by 30, i.e. the level obtained is between 0-30m.

5 Display

Using the joystick it is possible to navigate between the various menus. A menu is a list of items that can be scrolled using the UP and DOWN keys. Some menu items are purely informational, while others allow to access a submenu or interact with the displayed item. To enter the submenu use the RIGHT key and to exit use the LEFT key. In some cases, pressing the CENTRE key will execute an alternative or contrary function to the RIGHT key.

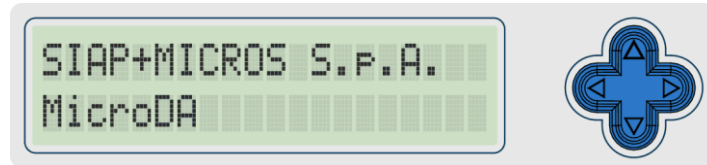

Press the RIGHT key to turn on the display and you will enter the first item of the first menu. The display will remain on but if left unused for more than ten⁷ minutes it will automatically turn off. Backlight is turned on when the display is switched on and stays active as long as the joystick is used. If no joystick button is pressed, backlight automatically turns off after 20 seconds and is reactivated when a joystick button is pressed.



5.1 Main menu

Display	Description	JoyStick
SIAP+MICROS S.P.A. MicroSUM	Welcome message	
HW=1234 SN=1001 FW=0.1.1	HW=Hardware model identification number SN=Product serial number FW=Firmware version installed	
Mobile=HL7692 RSSI=83dBm	Sierra Wireless mobile modem model	RIGHT
Main menu Sensor measurements	Allows to access the submenu “Sensor measurements”	RIGHT
Main menu Sensor History	Allows to access the submenu “History sensor”	RIGHT
Main menu Constant editor	Allows to access the submenu “Constant editor”	RIGHT
Main menu Advanced features	Allows to access the submenu “Advanced features”	RIGHT

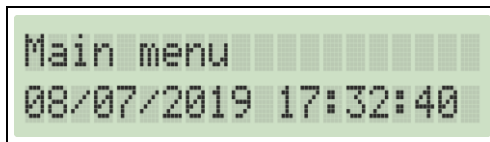
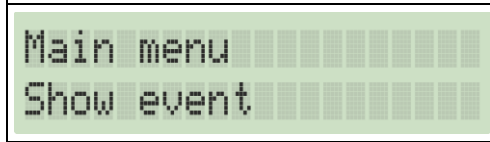
⁷ From fw version 0.20.10, in the previous fw versions display turns off after five minutes.

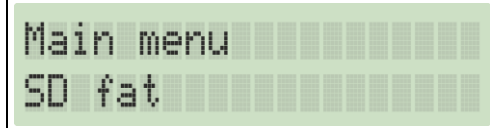
 <pre> Main menu 08/07/2019 17:32:40 </pre>	Shows the RTC value	
 <pre> Main menu Show event </pre>	Allows to access the submenu to check and view the various events found by the system	RIGHT
 <pre> Main menu NOR fat </pre>	Allows to access the submenu for access to the filesystem installed internally on the NOR.	RIGHT
 <pre> Main menu SD fat </pre>	Allows to access the submenu for access to the filesystem installed internally on the SD.	RIGHT

5.2 Sensor History Menu

This menu shows the historical values of each sensor. Initially It can be possible to access the list of sensors, once the desired one have been chosen, pressing right displays the number of data, the minimum and maximum of today's day. Moving vertically it is possible to move back and forth over time. By pressing right you will enter the selected day and you see the first value with its time. Moving vertically you move in the time of this sensor and this day.

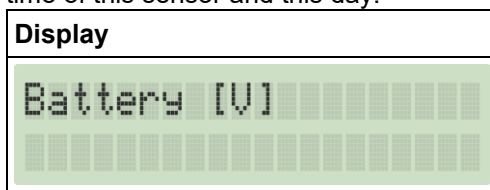
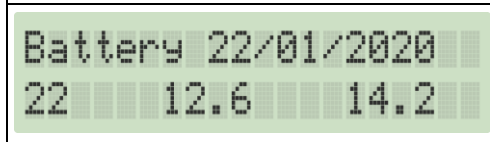
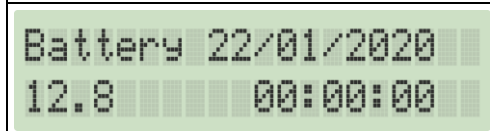
Display	Description	Action JoyStick
 <pre> Battery [U] </pre>	First level is shown the list of sensors. Scroll with HIGH and LOW, you exit with LEFT.	RIGHT
 <pre> Battery 22/01/2020 22 12.6 14.2 </pre>	Second level is shown for each day the number of data the minimum and the maximum value stored. Go through the days with HIGH and LOW, you go out with LEFT.	RIGHT
 <pre> Battery 22/01/2020 12.8 00:00:00 </pre>	Third level is shown each individual value and its time. Scroll through time with HIGH and LOW, you exit with LEFT.	RIGHT

The first level scrolls through the list of parameters or sensors. In the case of wind, three values are available, the Vector, the Scalar and the Gust. In the case of the rain gauge 2 values are available, the rain fall and the intensity of rain.

The second level normally displays the number of data, the minimum and the maximum daily value. In the rain drop rain sensor the number of data and the rain fell in the day is displayed.

The third level allows to scroll through time and view every single piece of data. Pressing the RIGHT button allows to immediately reach the last value of the da.

5.3 Sensor measurements menu

The most recently acquired values of each sensor are shown in this menu. The first row is the name and the second its value. The value is normally acquired at each DTC "Sampling delta" and automatically updated on the display every 10 seconds. To acquire a spontaneous value out of sync, press the RIGHT key and the measurement is executed and the data is updated. In order to get an instant measure outside the programmed sampling time, press the right key and values will be updated on the display. So as to make sensor power supply and measurement acquisition procedure easy, when the right key is pressed power supply available on the serial port or analog input connector where the sensor is connected is activated and it remains on until the display is turned off. This allows the sensor to be powered for as long as it takes the field operator to test the sensor⁸.

In the particular case of the rain gauge, 2 numbers are shown, the sum total and the rain intensity.

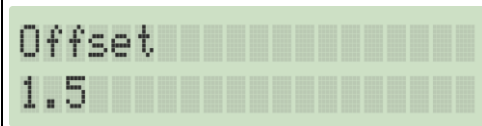
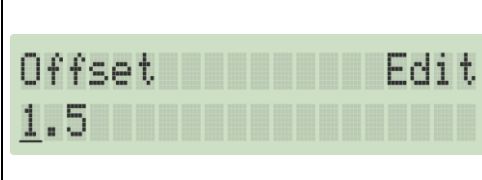

5.4 Menu constant editor

Editor menu allows to show and change datalogger parameters (see chapter 2.1.5). Parameter menu shows all configured parameters. In order to change the value of a parameter, pressing right key on that parameter to access editor menu (see the EDIT label on the top right corner of the display). Below an example of displaying a parameter named Offset with value 1.5:

Display	Description	Action JoyStick
	Shows name and value of the parameter	RIGHT to change the value
	Editor menu. Digits can be scrolled pressing right and left keys. It is possible to change the single digit of the value pressing up and down keys. If the cursor is positioned under the leftmost digit e left key is pressed the editor menu exits without saving.	CENTER PUSH to save the value, LEFT to exit without saving

5.5 Modem C feature menu

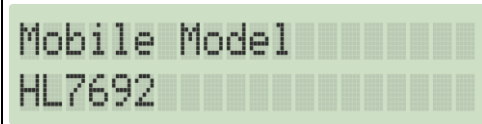
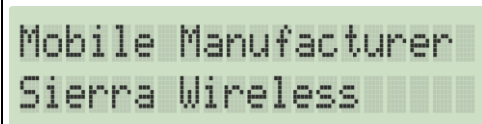
This menu shows the features of the internal modem.

Display	Description	Action JoyStick
	Displays the name of the modem manufacturer	
	Displays the name of the modem model	
	Displays the firmware version installed on the modem	

⁸ Available from fw version 0.20.10.

Mobile IMEI 355465070598053	Displays the IMEI code of the modem	
Mobile Serial Number VE833740060210	Displays the Serial Number of the modem	
Mobile Last RSSI -79 dBm	Displays the last value of the RSSI	
Mobile FOTA Connection to server	Allows FOTA update	

5.6 Advanced functions menu

In this menu very particular views are possible, reserved for expert personnel.

Display	Description	JoyStick
USB off Next Use in Comm.Dev	This item shows the use of the USB, whether it is active and in which mode it works or will work.	RIGHT to change mode
Update Firmware	If the NOR:/CONFIG/MICRODA.HEX file is present, a firmware update can be executed.	RIGHT to execute
Debug Level=1	The debug level set in the configuration can be temporarily modified	RIGHT to increase the level CENTRE to decrease the level
Debug Filter ACQ TRA SYS	The debug concerns all the various activities. Some can be temporarily excluded	RIGHT to repeatedly changes the activities shown
Reboot	A reboot can be performed without removing the power supply	RIGHT to perform
Flush Memory (xxx) On FAT	The data is temporarily in the volatile memory and will be lost in case of shutdown. Quantity of data in brackets	RIGHT to save
Datalogger ON Normal state	Data storage can be temporarily suspended. Temporal function.	RIGHT to perform
COM2 12V off	Shows and changes the state of power supply on COM2 (see the note at the bottom of the table).	RIGHT to perform

COM3 12V off	Shows and changes the state of power supply on COM3 (see the note at the bottom of the table).	RIGHT to perform
SDI-12 12V off	Shows and changes the state of power supply on SDI-12 (see the note at the bottom of the table).	RIGHT to perform
AIN1 boost 12V off	Shows and changes the state of 12V power supply on AIN1 (see the note at the bottom of the table).	RIGHT to perform
AIN2 boost 12V off	Shows and changes the state of 12V power supply on AIN2 (see the note at the bottom of the table).	RIGHT to perform
+AN1=xxx +COM=xxx +AN2=xxx	The power supplies are protected and deactivated if necessary. The status is shown	
18.1V 12.7V 0.03W UF 128 0.002A	The battery charge status is shown.	
Remove all rec. data	Removes all internally logged data of NOR and CACHE. To be used after a complete reconfiguration of the Micro SUM	
Sierra RX disable	Shows the reception state from modem. Press right key to change reception state (enabled or disabled).	RIGHT to perform

Note: Pressing of the joystick right key allows to change the state of the power supply only if at that moment no other datalogger task is using it. If the power supply has been already activated, e.g. by an acquisition task programmed in configuration with a certain sampling time, the attempt to change the state of the power supply will have no effect. In this case it's necessary to wait for the acquisition task to be completed. As a consequence, if the power supply is set in configuration to be always active (see Tsupply parameter in chapters 2.2.1 and 2.2.2), it cannot be switched off by the display as it is managed continuously by the acquisition task. If one or more power supplies are activated by the display, they can be switched off by changing their state from the display menu, otherwise they stay active until the display turns off (manually or automatically after ten minutes)⁹.

⁹ Available from fw version 0.20.10.

5.7 Events menu

This menu allows to evaluate how often certain events occur during datalogger operation. With these values, proper operation of the system can be kept under control.

Display	Description
Event reset Xxx found	Number of firmware resets
Event new config Xxx found	Number of new configurations installed and launched.
Event erase bank 1 Xxx found	How many times the Flash 1 bank has been erased in order to contain the firmware.
Event erase bank 2 Xxx found	How many times the Flash 2 bank has been erased in order to receive new firmware.
Event copy b2 >> b1 Xxx found	How many times new firmware has been copied on the RAM bank
Event hours Xxx found	How many hours of operation the datalogger has.
Event format NOR Xxx found	How many times the internal NOR has been formatted
Event MODEM on Xxx found	How many times the UMTS/LTE modem has been turned on.
Event MODEM error Xxx found	How many times the modem has been turned off following an error.
Event sTime NTP Xxx found	How many times the datalogger time has been changed
Event CHKDSK Xxx found	How many times the internal archive has been checked.
From SuperCHKDSK Xxx days	How many days have passed since the last detailed check of the internal archive

Event lost [] [] [] [] [] [] [] [] [] [] Xxx found [] [] [] [] [] [] [] [] [] []	How many events have been lost.
---	---------------------------------

5.8 NOR/SD fat menu

These two menus allow to browse and check the files contained in the two filesystems:

Display	Description
NOR=/ Select path	Allows to navigate in the filesystem. Shows the name of the file or folder with the addition of <dir>. RIGHT to enter the folder. LEFT to exit the folder or the menu. UP or DOWN to navigate in the folder. CENTRE to select the folder or file.
NOR=/ Delete	Allows to recursively delete the selected route. Press RIGHT 3 consecutive times to delete the file and/or folder.
NOR=/ Copy	Allows to recursively copy the selected path to the other device. Press RIGHT 3 consecutive times to copy the file and/or folder.
NOR=/ Format	Allows to format the filesystem. Press RIGHT 3 consecutive times to start.
NOR=/ Use	Allows to execute the selected file. In particular, if an XML file is selected it allows to update datalogger configuration, while if a HEX file is selected it allows to update datalogger fw. This operation is useful if you want to update datalogger configuration or datalogger fw from SD card.

6 MODBUS RTU protocol

The Micro SUM datalogger replies on the programmed serial ports and the virtual USB port with MODBUS RTU protocol. The protocol is developed on a request and response mechanism. Call syntax:

Request / Response		
Definition	Occupation [bytes]	Permitted values
ID	1	0 – 247 o 255
FN	1	1-127
CORPO	n	...
CRC	2	MSB LSB

The ID field is programmed with the identity parameters of the configuration, but the Micro SUM also responds to the number 255 used as a broadcast address.

The following standard functions can be used:

FN03	Read Holding Registers
FN04	Read Input Registers
FN16	Write Multiple Registers

The mapped functions from 65 to 72 can be used freely and the following functions have been used:

FN65	Siap+Micros ASCII Commands
FN67	Siap+Micros Binario Commands

The response is composed in the same way but the body is different between Request and Response, and an error response is sent:

Error		
Definition	Occupation [bytes]	Permitted values
ID	1	0 – 247 o 255
FN	1	FN+0x80
EXCEPT	1	1-n
CRC	2	MSB LSB

6.1 Standard commands

Currently, only FN04 “Read Input Registers” is implemented, where the following parameters can be read in “Swapped Float” format:

Register	Parameter definition (Swapped float)
1 2	Last rainfall not offset in progress
3 4	Last intensity at minute (-2)
5 6	Last rainfall at minute (-1)
7 8	Seconds of internal clock in progress
9 10	Rainfall offset in progress

21 22	Rainfall at minute (-1) last available
23 24	Intensity at minute (-1) last available
25 26	Rainfall at minute (-2) penultimate
27 28	Intensity at minute (-2) penultimate
...	...
(i-1)*4+21	Rainfall at minute (-i)
(i-1)*4+23	Intensity at minute (-i)
...	...
137 138	Rainfall at minute (-30)
139 140	Intensity at minute (-30)
1001 1002	Hardware revision
1003 1004	Software revision
1005 1006	Modbus ID
1007 1008	High SN
1009 1010	Low SN
1011 1012	A Area of mouth in cm ²
1013 1014	Vb Volume of the rocker in cm ³
1015 1016	R Resolution in mm
	Parameters of the formula $e=f(lm)=a_4lm^4+a_3lm^3+a_2lm^2+a_1lm+a_0$
1017 1018	A ₀
1019 1020	A ₁
1021 1022	A ₂
1023 1024	A ₃
1025 1026	A ₄
2001 2002	Last value of sensor 1 Valore ultimo del sensore 1
2003 2004	Last value of sensor 2
...	...
2199 2200	Last value of sensor 100
2501 2502	Measurement identifier of sensor 1
2503 2504	Measurement identifier of sensor 2
...	...
2699 2700	Measurement identifier of sensor 100

6.2 ASCII commands

With the command FN65, several ASCII subcommands are implemented that are normally used between DAK and Datalogger with the following syntax:

Request and Response 65		
Definition	Occupation [bytes]	Permitted values
ID	1	0 – 247 o 255
FN65	1	65
LEN	2	MSB LSB (n)
CORPO	n	...
CRC	2	MSB LSB

The LEN field is the length in bytes of the BODY. The format is identical between request and response.

	Command	Response
Station ID request		
	R IDSTAZ	IDSTAZ <id> <id> number
Storage ID request		
	R ID_MEM	ID_MEM <id> <id> number
Change station ID This command is sent in broadcast and allows to modify <id> sono to the selected data logger		
	WSN <sn> IDSTAZ=<id> <sn> serial number of the data logger <id> new number to set	IDSTAZ <id> <id> number
LCD reading		
	LCD	ON OFF <first line> <second line>
JOYSTICK movement		
	JOY U D L R P	ON OFF <first line> <second line>
Clock reading		
	CLK	CLK <hh> <mm> <ss> <dd> <mt> <yyyy> <hh> hour <mm> minute <ss> second <dd> day <mt> month <yyyy> full year
Clock programming		
	CLK <hh> <mm> <ss> <dd> <mt> <yy>	CLK <hh> <mm> <ss> <dd> <mt> <yyyy>

	hh> hour <mm> minute <ss> second <dd> day <mt> month <yy> year without century <	<hh> hour <mm> minute <ss> second <dd> day <mt> month <yy> year without century <yyyy> full year
Device version reading (Also used to prepare for receipt of a new configuration)		
	!FW	Micro SUM HW=<hh> SN=<sn> SW=<sw> <hw> hardware code <sn> serial number <sw> software version
Programming of a part of the configuration file (Appends to what had already been received previously)		
	!WR 0 <dat> <dat> a part of the configuration file	Empty response
Programming of a part of the configuration file (With reception address to append properly)		
	!WRB 0 <add> <dat> <add> address to write to (7 characters) <dat> a part of the configuration data	Empty response
Restart the datalogger with the new configuration		
	MICROS RESET	MICROS RESET
Restart of the data logger by forcing a block and by watchdog		
	!TW	Terminating Watchdog
Reading of the "maximum size of the archive" which contains the configuration.		
	R_FILE0	_FILE0 <Klen> <Klen> maximum size in Kbyte
Returns the configuration send pointer to zero. (An XML file is created that is congruent with the configuration being executed and the send point is reinitialised).		
	!RE 0 1	Empty response
Requests free space on the configuration file (This is the maximum size that contains the configuration, less the size of the configuration file)		
	!FR 0	<free> <free> free space in bytes
Requests a piece of the configuration file with packets of max 1000 byte (5x200)		
	!RD 0 1 <n>	Some data

Confirms receipt of the package and the progress of the transmission pointer		
	!RS 0 1	Empty response
Program internal parameter <n> to the value <m>		
	!WA 1 <n> <m>	Empty response
Requires instant data of S + M format		
	!RD 1 1	An instant data record
Reading of the latest data (set of data, depends on the managed DT, for example 20 minutes)		
	!LTR 6 [<yyyy> <mt> <dd> <hh> <mm> <ss>] <yyyy> year with century <mt> month <dd> day <hh> now <mm> minute <ss> second	Data response in dynamic S + M or ascii format
Read previous data (only the required record)		
	!DTR 6 <yyyy> <mt> <dd> <hh> <mm> <ss> <yyyy> year with century <mt> month <dd> day <hh> now <mm> minute <ss> second	Data response in dynamic S + M or ascii format
Read previous data (set of data of the requested period, similar to the LTR)		
	!ETR 6 <yyyy> <mt> <dd> <hh> <mm> <ss> <yyyy> year with century <mt> month <dd> day <hh> now <mm> minute <ss> second	Data response in dynamic S + M or ascii format
Displays some log <n> a where if omitted from the end		
	!LOG <n> <n> from what point	Some data

6.3 Binary commands

With this FN67 command, binary information is transmitted and simultaneously the datalogger is informed of the time, so that the two systems are continuously aligned. They are internal controls, both forwards and backwards. Syntax:

Request and Response 67		
Definition	Occupation [bytes]	Permitted values
ID	1	1 ÷ 127
FN67	1	67
LEN	2	MSB LSB (n+7)
CMD	1	0 ÷ 255
TIME	6	AAMMGghmmss
CORPO	n	...
CRC	2	MSB LSB

LEN is the length of the message, but also includes CMD, TIME and CORPO, or n+7.

Command	Use	Definition
0	General	Request Firmware version
3	General	Clock writing
6	General	Start UPDATE
7	General	UPDATE
8	General	Write IDENTITY
9	General	Read IDENTITY
20	Rain Gauge	Start of calibration procedure
21	Rain Gauge	End of calibration procedure
22	Rain Gauge	Read calibration results
23	Rain Gauge	Start tilting
24	Rain Gauge	Stop titling
26	Micro SUM	Write calibration parameters
27	Micro SUM	Read calibration parameters
28	Micro SUM	Outputs the 512Hz frequency on the TP2 test point
29	Micro SUM	Performs an accurate measurement of a channel to calibrate it

6.3.1 Command 0 = Firmware version

Request FN=67 CMD=0 Version Firmware

The request does not have a BODY, so LEN=7.

Response FN=67 CMD=0 Version Firmware

Desc	Stringa ascii descrittiva	n byte
------	---------------------------	--------

6.3.2 Command 3 = Clock writing

Request FN=67 CMD=3 Clock writing

The request does not have a BODY, so LEN=7.

Response FN=67 CMD=3 Clock writing

6.3.3 Command 6 = Start UPDATE

Request FN=67 CMD=6 Start UPDATE

nTot	Overall number of ASCII records in INTEL HEX FORMAT	2 byte
------	---	--------

With this request the sending of records in INTEL format is initialised.

Response FN=67 CMD=6 Start UPDATE

Status	0=OK	1 byte
--------	------	--------

6.3.4 Command 7 = UPDATE

Request FN=67 CMD=7 UPDATE

nSend	Number of the first record transmitted [1..Ntot] in INTEL HEX FORMAT	2 byte
nRec	How many records I'm transmitting	2 byte
ASCII	Part of the records	

With this request the nRecs are sent that must be consecutive starting from 1 to nTot in INTEL format.

Response FN=67 CMD=7 UPDATE

Status	0=OK	1 byte
--------	------	--------

6.3.5 Command 8 = Write identity

Request FN=67 CMD=8 Write identity

HardwareCode	Identification of the hardware	4 byte
SerialNumber	Serial number	4 byte

With this request the identity is programmed. Attention: limited number

Response FN=67 CMD=8 Write identity

Status	0=OK	1 byte
--------	------	--------

6.3.6 Command 9 = Read identity

Request FN=67 CMD=9 Read identity

The request does not have a body, so LEN=7.

Response FN=67 CMD=9 Read identity

HardwareCode	Identification of the hardware	4 byte
SerialNumber	Serial number	4 byte
Status	Programmed block (0..127)	1 byte

6.3.7 Command 26 = Write calibration parameters

Request FN=67 CMD=26 Write calibration parameters

ADC Offset	Offset voltage (μ V)	4 bytes float
Vref	Voltage reference (V)	4 bytes float
Iref	Current reference (mA)	4 bytes float

With this request, calibration is programmed

Response FN=67 CMD=26 Write calibration parameters

Status	0=OK	1 byte
--------	------	--------

6.3.8 Command 27 = Read calibration parameters

Request FN=67 CMD=27 Read calibration parameters

The request does not have a BODY, so LEN=7.

Response FN=67 CMD=27 Read calibration parameters

ADC Offset	Offset voltage (μ V)	4 bytes float
Vref	Voltage reference (V)	4 bytes float
Iref	Current reference (mA)	4 bytes float

6.3.9 Comand 28 = Emit frequencies

With this command the Micro SUM provides on the TP2 test point the original frequency of the quartz of the watch at 32768Hz divided by 64 or 512Hz. The read parameter can be inserted into the calibration parameters to improve the behavior of the RTC.

Request FN=67 CMD=28 Emit frequencies

The request has no BODY, so LEN=7.

Response FN=67 CMD=28 Emit frequencies

Status	0=OK	1 byte
--------	------	--------

6.3.10 Comand 29 = Perform measurement by calibration

Request FN=67 CMD=29 Perform measurement by calibration		
ID fisico della misura	1..8 = AN Singolo 1..8 9..10 = PT100 1..2 11..14 = AN Differenziale 1..4 15..17 = Digitale IN 1..3 18..20 = Digitale OUT 1..3 21..22 = V OUT 1..2 23..24 = I OUT 1..2 25 = Battery 26 = Use 27 = Panel 28 = In charge 29 = Temperature	1 byte
Parametro OUT	Only for OUTPUT. It is the vaue to be set	4 byte float

With this command the Micro SUM performs a good measurement of a channel without applying corrective formulas. therefore It allows to calculate the calibration parameters.

Response FN=67 CMD=29 Esegui misura per calibrazione		
Status	O=OK	1 byte
Average size	For INPUT only It is the measured average value	4 byte float
Standard deviation measurement	For INPUT only It is the standard deviation	4 byte float

7 Data acquisition

When acquiring a value from a channel, the number is represented in the formula by the acronym M0 and the unit of measurement depends on what is being acquired.

7.1 Analog

Single analog channel. Expressed in μV . Range between 0V and 2.5V, therefore a number between 0 and 2500000.

Differential analog channel. Expressed in μV . Range between -2.5V and 2.5V, therefore a number between -2500000 and 2500000.

PT100 analog channel. Expressed in Ohm. Range between 80 Ω and 150 Ω .

7.2 Digital

The unit of measurement depends on the type that was chosen:

Frequency	Average frequency expressed in Hz with 0.1Hz resolution.
Period	Average period expressed in seconds with 0.1s resolution.
Count	Number of cycles with half-cycle resolution. The sum of the events is recorded at the DTR.
Lenght 0	Duration of level 0 expressed in seconds with 0.1s resolution The total duration is recorded at the DTR
Lenght 1	Duration of level 1 expressed in seconds with 0.1s resolution The total duration is recorded at the DTR.
DutyCycle 0	Average duty cycle of level 0 expressed in% with 0.1% resolution.
DutyCycle 1	Average duty cycle of level 1 expressed in% with 0.1% resolution.
Sample 0	If at sampling the logical value is 0, the value is the time in seconds of the sampling time. Upon registration, the sum of the total durations is stored
Sample 1	If at sampling the logical value is 1, the value is the time in seconds of the sampling time. Upon registration, the sum of the total durations is stored
Logical	Logical sampled value.

7.3 Internal

The unit of measurement depends on the type that has been chosen:

Battery	Battery voltage expressed in V.
Consumption	Current consumption in mA.
Photovoltaic panel	Solar cell voltage in V.
Charge	Current drawn from the solar cell in mA
RSSI	Signal quality expressed in dBm. A correctly detected value is in the range [-113dB, -51dBm], but if the parameter is not known or not detectable the value is +99. The lower the absolute value of the measure, the better the signal.

7.4 Serial ports

When acquiring a value from a serial channel (Modbus or SDI-12), the number is represented with the same unit of measurement as the external sensor.

7.5 Conversion formula

When a value is acquired, it can be converted into its engineering unit by using a formula. This is written in a string of up to 80 characters, which can be either upper or lower case and contain spaces.

The numerical values can also be in the scientific version with the exponent E+ or E-, and the decimal separator is the point "." and not the comma ",".

In developing the formula, round brackets "(" and ")" can be used to alter the natural order of the calculation.

Variables in memory

MO	Is the value of the measurement just acquired by the channel. The value -9999 indicates an invalid or incalculable value. The value -9998 indicates a missing, unacquired value.
-----------	--

Arithmetic operators

+	Addition
-	Subtraction
/	Division
*	Multiplication
^	Raise to power
MOD	Rest of division (equivalent operator: %)

Logical operators

NOT	Logical negation (equivalent operator: !)
AND	Logical conjunction
OR	Logic disjunction

Comparison operators

=	Equal to
>	Greater than
<	Less than
?	Different

Bit comparison operators

&	Bitwise AND
 	Bitwise inclusive OR

Boolean constants

FALSE	Equivalent to the value 0
TRUE	Equivalent to the value 1

Mathematical functions

ABS	Absolute value of a number.
------------	-----------------------------

ATN	Arctangent of a number.
COS	Cosine of an angle expressed in radians.
EXP	Raise to power of natural logarithms (base e).
INT	Whole part of a number.
LIM	Maximum or minimum value of a number between two limits, for example LIM (value, max, min).
LN	Natural logarithm of a number.
LOG	Logarithm base 10 of a number.
MAX	Maximum value between two numbers, for example MAX (value1, value2).
MIN	Minimum value between two numbers, for example MIN (value1, value2).
SGN	Sign of a number.
SIN	Sine of an angle expressed in radians.
SQR	Square root of a number.
TAN	Tangent of an angle expressed in radians.

8 **FTP transmission**

FTP transmission allows to send to the configured FTP servers data records saved in NOR flash memory and cache memory. For each FTP servers an IP address, port, login credentials (username and password), remote path where data files are saved, data file format and prefix assigned to the name of the data files are defined. The name of the data file created on the remote path is:

<prefix>_<year><month><day><hour><minutes><seconds>.txt

For example, *ST011_20220704081038.txt* is the data file sent at 8:10:38 on 04/07/2022 with prefix ST011. For each FTP server the datalogger keeps track of the last record sent in order to ensure a correct sequence of data transmission in the scheduled transmission intervals. To preserve this information from system shutdown and reboot, data transmission pointers are saved in NOR flash memory. The update of these pointers is performed 1h after the last save. Data transmission pointers are uniquely identified by the name assigned in configuration to the FTP server phase.

In order to ensure the correct operation of the data transmission pointers, different names must be assigned in configuration to the FTP server phases. A maximum of 10 transmission pointers are managed.

In addition to sending data, the data logger can also download files from FTP servers.

8.1 XML file download for configuration update

Once data records have been sent, the data logger checks if there is an XML file in a specific path of the FTP server. Path and name of the searched file are:

<path>/Config/<prefix>/CFG_TMP.XML

Path and prefix correspond respectively to Path and Prefix fields of the FTP server phase set in configuration (see 2.3.1.1). If the XML file exists the data logger starts the download. At the end of the download *CFG_TMP.XML* file is deleted from FTP server and then current configuration file and newly downloaded configuration file are sent to the same path with the names *CFG_OLD.XML* and *CFG.XML* respectively. At the end of this download and upload phase, the data logger starts the configuration update procedure.

8.2 HEX file download for firmware update

If there is no XML file the data logger checks whether there is an HEX file in the same remote path. Path and name of the searched file are:

<path>/Config/<prefix>/MICRODA.HEX

Path and prefix correspond respectively to Path and Prefix fields of the FTP server phase set in configuration (see 2.3.1.1). If the file exists the data logger starts the download. Once completed, *MICRODA.HEX* file is deleted from FTP server and then the firmware update procedure is started.

To successfully download files from an FTP server, XML and HEX files must be named exactly as shown in the description above. Downloading HEX files can take a few minutes.

9 SMS Comand

Below is a description of all the SMS commands supported by the Micro SUM.

SMS COMAND	ANSWER	DESCRIPTION
SHOW THRESHOLD <ID>	THRESHOLD <ID> Llmax=<SU> ALmax=<SUP alarm threshold> ATmax=<Support SUP attention> ATmin=<INF attention threshold> ALmin=<INF alarm threshold> Llmin=<INF> HY=<isteresi>	Requires thresholds set for the sensor with identifier <ID>.
CHANGE THRESHOLD <ID> Llmax=<SU> ALmax=<SUP alarm threshold> ATmax=<Support SUP attention> ATmin=<INF attention threshold> ALmin=<INF alarm threshold> Llmin=<INF> HY=<isteresi>	THRESHOLD <ID> Llmax=<SU> ALmax=<SUP alarm threshold> ATmax=<Support SUP attention> ATmin=<INF attention threshold> ALmin=<INF alarm threshold> Llmin=<INF> HY=<isteresi>	Allows you to vary a threshold for the sensor with identifier <ID>. Send only the thresholds you want to change. The response returns the new thresholds set by the command.
SAVE RUNTIME	OK	Allows to make changes to configuration parameters made with SMS commands definitive.
FTP FROM <N>	OK	Set <N> data to be sent to configured FTP servers hours back in time.
STATUS RAIN	RAIN 1H=< cumulative rain> 3H=< cumulative rainfall> 6H=< cumulative rainfall > 12H=< cumulative rainfall > 24H=< cumulative rainfall >	Requires the state of the detected rain. Returns the accumulated rain in the last 1, 3, 6, 12 and 24 hours.
STATUS LAST	LAST 1 < measure name 1>=< value > < measure name 2>=< value > < measure name 3>=< value >	Requires the latest measurements performed by configured captures. Each measure is described by the string <measure name>=<value>
REBOOT ⁽¹⁾	No answer	Commands a restart of the datalogger.
CHANGE APN=<apn> ⁽¹⁾	OK APN=<apn>	Allows you to change the APN (apn is the new Access Point Name that is wanted to set).
CHANGE FTP <ftp_server> IPADDR=< ip_address > USERNAME=<username> PWD=<password> ⁽¹⁾	OK <ftp_server> IPADDR=<ip_address> USERNAME=<username> PWD=<password>	Allows to change the IP address (<ip_address>), username (<username>) and password (<password>) of the FTP server phase identified by the name <ftp_server> assigned in configuration. The command can define all three parameters or only a few. Response returns the new values set by the command. See chapter 2.3.1.1.
CHANGE FTP <ftp_server> PATH=<path>	OK <ftp_server> PATH=<path>	Allows to change the remote path (<path>), the format of the data sent

SENDMODE=<send_mode> FILEPREFIX=<file_prefix> ⁽¹⁾	SENDMODE=<send_mode> FILEPREFIX=<file_prefix>	(<send_mode>) and the prefix of the file of the FTP server phase identified by the name <ftp_server> assigned in configuration. The command can define all three parameters or only a few. Response returns the new values set by the command. See chapter 2.3.1.1
CHANGE FTP <ftp_server> MAXREC=<num_records> ⁽²⁾	OK <ftp_server> MAXREC=<num_records>	Allows to change the maximum number of records to send of the FTP server phase identified by the name <ftp_server> assigned in configuration. Response returns the new value set by the command. See chapter 2.3.1.1.
GET FW ⁽¹⁾	FW VERSION X.Y.Z	Requires the firmware version of the datalogger.
GET HW ⁽¹⁾	HW ID=<hw> SN=<sn>	Requires hardware ID and serial number of the card.
GET DIAG ⁽¹⁾	Esempio: Vbatt=12.35V Vps=18.95V Ich=560mA Temp=23.48°C	Requires diagnostic data from the datalogger. The answer returns the battery voltage, solar panel voltage, solar panel charging current, and internal temperature.
GET MODEM ⁽¹⁾	Esempio (per HL8548): Model: HL8548 Revision: RHL85xx.5.5.18.0.201506301553 .x6250_1 IMEI: 359515059889513 FSN: HD734603011410 RSSI: -58dBm	Requires data from the Sierra Wireless modem installed on the datalogger. The response returns the model, revision, IMEI, serial number, and RSSI.
CHANGE PARAM<id>=<value> ⁽³⁾	PARAM<id> <name>=<value> <unit_of_measurement>	Allows to change the value of the parameter identified by the index <id> ("index" field of the configuration). Response returns the name of the parameter, the new set value and the unit of measurement.

⁽¹⁾ From version fw 0.18.22.

⁽²⁾ From version fw 0.23.4.

⁽³⁾ From version fw 0.27.2.

NOTE: Changing parameters (numeric or strings) using the CHANGE THRESHOLD, CHANGE APN, CHANGE FTP and CHANGE PARAM commands is only temporary. In the event of a restart, the values on the configuration file are restored. To persist the setting of the new values, use the SAVE RUNTIME command.

10 Revision history

The following table provides a description of the changes made to this document.

Version	Date	Updates
01	27/04/2020	First version of the document.
02	27/10/2021	Added: <ul style="list-style-type: none"> Description of the "Store Event" parameter in chapter 2.2.1 Chapter 12.9 with the description of the logging of rain gauge weather events. Updated: <ul style="list-style-type: none"> Description of the "MskElab" parameter in chapter 2.2.3. Description of the "Type" parameter in chapter 2.3.1.1.
03	11/11/2021	Added: <ul style="list-style-type: none"> Chapter 9 SMS commands with the description of the SMS commands supported by the Micro SUM. Updated: <ul style="list-style-type: none"> Description of the "Option" field in chapter 2.1.3.
04	25/05/2022	Added: <ul style="list-style-type: none"> Chapter 2.1.5: datalogger parameter. Chapter 5.4: menu constant editor. Updated: <ul style="list-style-type: none"> Description of the time in which the display and its backlight stay on. Description of main menu chapter 5.1: added constant editor. Description of sensor measurement menu in chapter 5.3. Description of advance features menu in chapter 5.6 Description of NOR/SD fat menu in chapter 5.8
05	22/12/2022	Added: <ul style="list-style-type: none"> Chapter 8: FTP transmission. Updated: <ul style="list-style-type: none"> Name of the datalogger changed to Micro SUM.
06	16/02/2023	Added: <ul style="list-style-type: none"> Chapter 2.2.4: Acquisition job from Modbus sensor with start measurement command.
07	18/04/2023	Updated: <ul style="list-style-type: none"> Chapter 9: new SMS command to change FTP server phase parameters.
08	30/08/2023	Updated: <ul style="list-style-type: none"> Description of input and output power supplies as required by EN61010-1 safety standard in chapter 3.6. Description of electrical protection circuit of analog inputs and outputs and digital inputs and outputs in chapters 3.1, 3.2, 3.3 and 3.4. Description of electrical protection circuit of serial ports in chapter 3.5. Information of environmental operating conditions in chapter 1.3. Added: <ul style="list-style-type: none"> Chapter 2.4 description of signal LEDs.

09	14/02/2024	<p>Updated:</p> <ul style="list-style-type: none"> Chapter 2.1.3: added a new parameter to define the waiting time for network registration. Chapter 2.2.1.2: added a new parameter to define start concurrent measurement commands. Chapter 2.2.2.3: added modem RSSI as internal measure.
10	23/02/2024	<p>Updated:</p> <ul style="list-style-type: none"> Chapters 2.2.1.1, 2.2.1.2, 2.2.2.1, 2.2.2.2, 2.2.2.3 and 2.2.4.1: added configuration parameters to drive analog and digital outputs. Chapter 3.3: updated the description of analog outputs. Chapter 3.4: updated the description of digital outputs.
11	07/06/2024	<p>Updated:</p> <ul style="list-style-type: none"> Chapter 1.7: added how to insert and remove SIM card and SD card.
12	28/08/2024	<p>Updated:</p> <ul style="list-style-type: none"> Chapter 9: added new SMS command to change a parameter.
13	18/12/2024	<p>Added:</p> <ul style="list-style-type: none"> Chapter 13: DAK software for management of MicroSUM datalogger.

All the information content in this document is the current available at the printing phase. Siap+Micros S.p.A. reserve the rights to change the specifications without any advance notice.

11 Declaration of Conformity



MD 751.1 rev. 03

EU Declaration of Conformity (DoC)

Manufacturer: SIAP+MICROS S.p.A.
 Via del Lavoro, 1 – 31020 S. Fior (TV) – Italy
<https://www.siapmicros.com/en/>

This declaration of conformity is issued under the sole responsibility of the manufacturer.

Object of the declaration:

Description	Product Code/Model
MICRO-MNB1 - MicroSUM Ultra Low Power Datalogger with integrated 4G LPWA Global module (cat. M1/NB1), analog and digital inputs, serial and microUSB interfaces with standard configuration	PEM-E020G-MICRO-MNB1

The object of the declaration described above is in conformity with the relevant Union harmonization legislation:

- **2014/53/EU** The Radio Equipment Directive (RED)
- **2011/65/EU** The Restriction of Hazardous Substances Directive (RoHSD)

The following harmonised standards and technical specifications have been applied:

RED references:

ELECTROMAGNETIC COMPATIBILITY (Article 3.1b):

EN 61326-1 2021-06	Electrical equipment for measurement, control and laboratory use - EMC requirements - General requirements
EN 301 489-1 V2.2.3:2019	ElectroMagnetic Compatibility (EMC) standard for radio equipment and services; Part 1: Common technical requirements; Harmonised Standard for ElectroMagnetic Compatibility
EN 301 489-52 V1.2.1:2021-11	ElectroMagnetic Compatibility (EMC) standard for radio equipment and services; Part 52: Specific conditions for Cellular Communication User Equipment (UE) radio and ancillary equipment; Harmonised Standard for ElectroMagnetic Compatibility

EFFECTIVE AND EFFICIENT USE OF RADIO SPECTRUM (Article 3.2):

EN 301 511 V12.5.1:2017-03	Global System for Mobile communications (GSM); Mobile Stations (MS) equipment; Harmonised Standard covering the essential requirements of article 3.2 of Directive 2014/53/EU
EN 301 908-1 V13.1.1:2019-11	IMT cellular networks; Harmonised Standard for access to radio spectrum; Part 1: Introduction and common requirements
EN 301 908-13 V13.1.1:2019-11	IMT cellular networks; Harmonised Standard for access to radio spectrum; Part 13: Evolved Universal Terrestrial Radio Access (E-UTRA) User Equipment (UE)



MD 751.1 rev. 03

HEALTH & SAFETY (Article 3.1a):

EN 61010-1 2010+A1:2021-11	Safety requirements for electrical equipment for measurement, control and laboratory use Part 1: General requirements
EN 62311 2019	Assessment of electronic and electrical equipment related to human exposure restrictions for electromagnetic fields (0 Hz to 300 GHz)

RoHSD references:

EN 63000 2016+AMD1:2022	Technical documentation for the assessment of electrical and electronic products with respect to the restriction of hazardous substances
-----------------------------------	--

Date
31-01-2023

CEO
Alex Stevanin

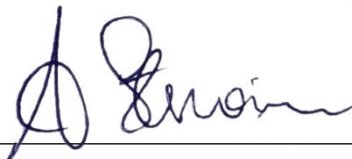

12 Appendices

12.1 Thresholds and Alarms

Two **Limit** parameters are associated to each sensor which allow, if set, to exclude from acquisition the numbers considered "invalid".

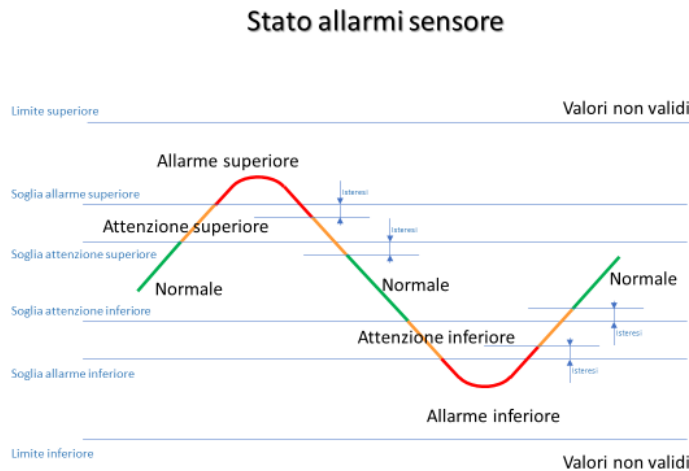

Four parameters are associated to each sensor which allow, if defined, to assign a state to the read value. They are **Alarm** and/or **Attention** thresholds, both **Upper** and **Lower**. Above or below a threshold you enter the defined state. To avoid effects, when the values oscillate around these thresholds, there is a Hysteresis parameter that moves the return point. This parameter is applied to all thresholds.

When a value changes state, an alarm is generated and an SMS is sent with the following text:

- [Name of location]
- [Name of sensor]
- ALARM | ALARM_INF | ATTENTION | ATTENTION INF | NORMAL
- [Acquired value that determined the state]
- Threshold
- Value of threshold that determines the state

For example: "Conegliano Temperature [°C] ALARM 28.3 Threshold 25.0".

Thresholds can be modified remotely by sending a specific SMS

(See Cap. 8 SMS Comand).

12.2 TP-Tilting rain gauge

The tilting rain gauge is a special sensor that uses two calibrated tilting trays to measure the rain that has fallen. The trays, once full, overturn signaling the event to the Micro SUM datalogger. Each overturning is equivalent to a quantity of water that has passed through the collection area and that corresponds to a certain level of accumulated water. The minimum level measured for a single rollover is also called rain gauge resolution. At low intensities each overturning corresponds to a precise value, but at high intensities, the overturning speed introduces a mechanical systematic error of underestimation that is difficult to eliminate. In fact, all the water that falls after the tray has started to move and before the new tray is in place, is lost.

Since the rain gauge is a repetitive and constant instrument, it is possible to measure this error and correct it via software in order to provide a more reliable final value. Cumulative rain values can then be adjusted in real time and transformed into rain intensities as per WMO prescription. The intensity of rain is the average value of water falling in the interval of one minute. It must be calculated and stored every minute and is expressed in mm/h. SIAP+MICROS has equipped itself with an automatic calibration system to certify its rain gauges according to the European standard EN 17277:2019 "Hydrometry – Requirements and classification of rainfall instruments for the measurement of precipitation intensity" which allows to classify as CLASS A the rain gauges that contain the error within 3% over the entire measurement range, normally 0-300 mm / h.

Therefore, a good mechanical system of tilting trays can be characterized experimentally over the entire measurement range. Measurement error is defined as the following relationship expressed in percent:

$$e[\%] = \frac{I_m - I_r}{I_r} \cdot 100$$

I_m is the intensity measured by the datalogger e , I_r the real intensity measured by the calibration system. After performing several tests it is possible to experimentally derive a polynomial that approximates the error function:

$$e = f(I_m) = A_4 * I_m^4 + A_3 * I_m^3 + A_2 * I_m^2 + A_1 * I_m + A_0$$

This function can be set in the Micro SUM datalogger. SIAP+MICROS has obtained for its rain gauges a unique formula for type of sensor, this allows the interchangeability of the datalogger with the rain gauges. The sensors are mechanically adapted to comply with this behavior and certified according to standard. The datalogger detects the time of each overturn and calculates the ΔT between two events. Knowing the volume of the tray and the collection area, the measured Intensity I_m is obtained. Through the polynomial it calculates the error and then the real Intensity I_r that determines the actual water transited in the collection area.

This system allows you to calculate both the real cumulative rain and the intensity of rain.

The value of accumulated rain can be recorded periodically in both ways as a progressive counter and as a rain fall in the range. The value is a real number with units of measurement [mm] expressed in floating points and not as an integer multiple of resolution.

The value of rain intensity is instead automatically recorded per minute with units of measurement [mm/h] also expressed in floating points.

Internally, the Micro SUM datalogger calculates the rain that has fallen in various intervals, from one hour to 24 hours, and compares them with as many thresholds to determine the alarm or attention status of the sensor. This allows the sending of SMS as for the other sensors.

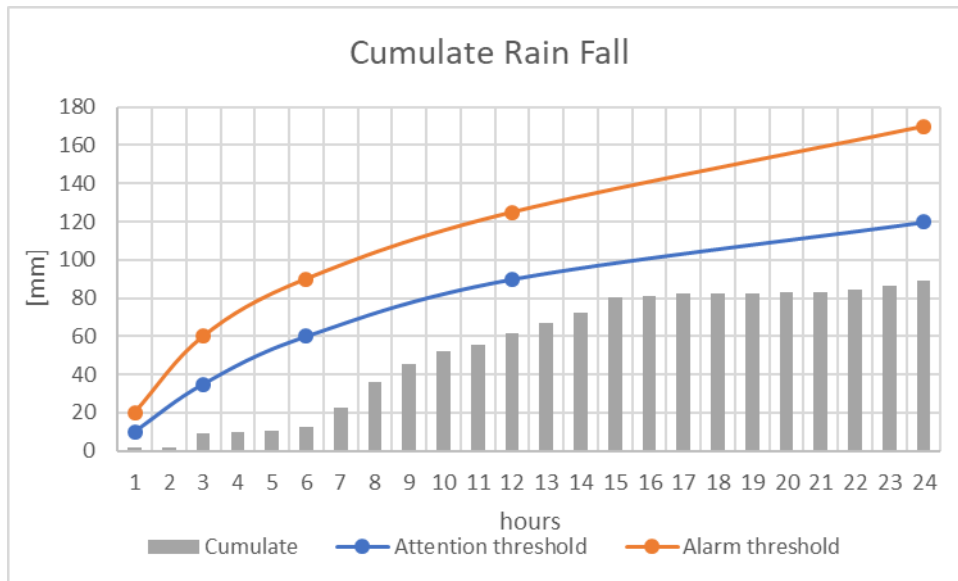

When the rain gauge changes state, an alarm is generated and an SMS is sent with the following compound text:

- [Place name]
- [Sensor name]
- ALARM | ATTENTION | NORMAL
- 1H=[Rainfall in 1 hour]
- 3H=[Rainfall 3 hours]
- 6H=[Rainfall in 6 hours]
- 12H=[Rainfall in 12 hours]
- 24H=[Rainfall in 24 hours]

Example: "Conegliano Raingauge ALARM 1H=1.9(**) 3H=5.0 6H=10.6 12H=55.4 24H=86.6"

The values that generated the status are followed by (*) to signal attention and (**) to signal the alarm.

Thresholds can be changed remotely by sending a specific SMS.

SMS to be sent	Meaning	SMS answer
SHOW THRESHOLD <ID>	Requires thresholds set for the sensor with ID=<ID> Only the values set return	THRESHOLD <ID> AL1=<programmed alarm in 1 hour> AL3=<programmed alarm 3 hours> AL6=< programmed alarm 6 hours > AL12=< programmed alarm 12 hours > AL24=< programmed alarm 24 hours > AT1=< warning in 1 hours > AT3=< warning in 3 hours > AT6=< warning in 6 hours > AT12=< warning in 12 hours > AT24=< warning in 24 hours >
CHANGE THRESHOLD <ID>	Allows to vary a threshold for the sensor with ID=<ID>	THRESHOLD <ID> AL1=<programmed alarm in 1 hour>

AL1=<programmed alarm in 1 hour> AL3=<programmed alarm 3 hours> AL6=< programmed alarm 6 hours > AL12=< programmed alarm 12 hours > AL24=< programmed alarm 24 hours > AT1=< warning in 1 hours > AT3=< warning in 3 hours > AT6=< warning in 6 hours > AT12=< warning in 12 hours > AT24=< warning in 24 hours >	Send only the thresholds it is wanted to change the change is only temporary and is not saved if you restart it returns to the initial value	AL3=<programmed alarm 3 hours> AL6=< programmed alarm 6 hours > AL12=< programmed alarm 12 hours > AL24=< programmed alarm 24 hours > AT1=< warning in 1 hours > AT3=< warning in 3 hours > AT6=< warning in 6 hours > AT12=< warning in 12 hours > AT24=< warning in 24 hours >
SAVE RUNTIME	Allows to make the changes made definitive.	OK

12.3 USB use

There are two operating modes of the USB:

- CDC, Communication Device Class, i.e. a virtual serial device where a continuous log of the Micro SUM operation is automatically activated, as well as a MODBUS protocol for query and configuration.
- MSC, Mass Storage Class, i.e. NOR and SD are displayed as external disks on which it is possible to read and delete. During this behaviour, the Micro SUM does not record or transmit. This mode has a maximum time of 60 minutes, after which it is released.

The mode of operation is chosen from the Advanced menu.

During use of the USB, the datalogger consumption is increased to allow easier operation.

Connecting the datalogger only with the USB will start the device in safe mode, i.e. it is not charged and the configuration is not activated, but it can be changed from the PC.

12.4 Memory

The data acquired from the sensors is sampled in observance of the DTC (sampling time, for example 3 seconds) and stored in a temporary memory called INTERIM. This area contains the partial counts like sums, minimums and maximums, vectors, squares, etc. At the DTR (recording time, for example 5 minutes), the requested counts are performed and set in the configuration. These are inserted in binary records that are stored in an area called CACHE. Every hour, the CACHE records are transferred to the NOR memory where there is a filesystem, and duplicated on the SD memory if necessary.

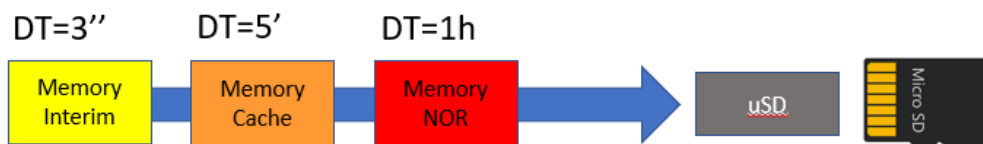

The filesystems are structured as follows:

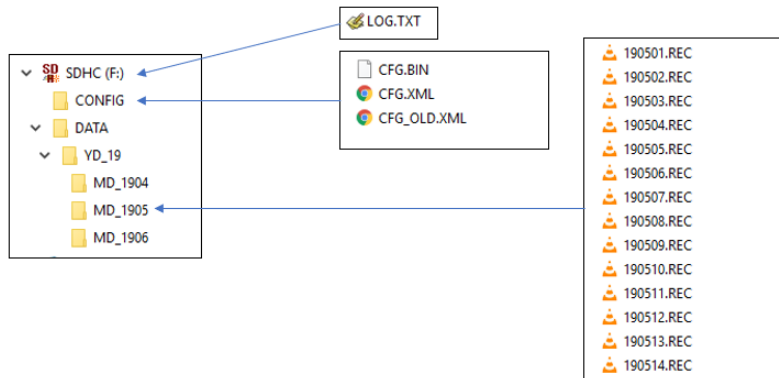

The data resides in a folder called DATA, grouped by year in folders that start with YD_year, further grouped by month in folders that start with MD_yearandmonth. The name of file is the date of the day of reference with a REC extension.

The configuration resides in a folder named CONFIG. The original file has an XML extension and is translated in binary format with BIN extension.

12.5 Provisional maintenance

During maintenance of a station activities can be carried out that involve disconnecting sensors for cleaning operations, knocking down the wind pole and manually inserting water into the rain gauge to test its functioning. These activities must be carried out with data logger on, but the data that are acquired, recorded and transmitted are biased due to maintenance operations. This is not always correct, as the data must then be deleted or processed differently. To solve this inconvenience in a preventive manner, it is possible to temporarily disable the operation. The following item is in the Advanced menu:

```
Datalogger ON [ ] [ ] [ ] [ ] [ ] [ ] [ ] [ ]
Normal state [ ] [ ] [ ] [ ] [ ] [ ] [ ] [ ]
```

By pressing the RIGHT key, the operation becomes:

```
Datalogger OFF [ ] [ ] [ ] [ ] [ ] [ ] [ ] [ ]
For next 3600 second [ ] [ ] [ ] [ ] [ ] [ ] [ ] [ ]
```

From this moment, for one hour the datalogger will operate and display the data correctly but it will not perform acquisitions and transmissions until the time limit or until the RIGHT key is pressed again. The count of rocker tilts is only shown for the rain gauge.

12.6 Power supply protections

All the power supplies are protected against overvoltage and reversal. The two 12V outputs provided on the analog inputs are limited to 1.5A individually and the three VBAT outputs on the serial ports are limited overall to 5A. When these values are exceeded, an electronic limiter is activated to reduce the supplied voltage and compensate the power factor. If this is not possible, for example in the case of a short circuit, the power supply is suspended until the power supply is removed and then restored. There is an Advanced menu that shows, for example:

```
+AN1=OFF [ ] [ ] [ ] [ ] [ ] [ ] [ ] [ ] +COM=OK [ ] [ ] [ ] [ ] [ ] [ ] [ ] [ ]
+AN2=FLT [ ] [ ] [ ] [ ] [ ] [ ] [ ] [ ]
```

If the power supply has been suspended, FLT (fault) is displayed. If the power supply is correct, OK appears. If the power supply is not supplied, the limiter is simply switched off and OFF is shown.

12.7 Battery charger

The Micro SUM datalogger is equipped with an extremely sophisticated battery charger. It is possible to connect a panel of up to 100W and a lead battery of considerable capacity and charge the system very efficiently. The battery is charged using two-phase control, at constant current and then at constant voltage. The values are compensated in temperature so as not to damage the battery in the event of sudden external temperature changes. The panel is managed so that it works at the point of maximum efficiency, called MPPT, and therefore obtains all the available solar energy. In the Advanced menu there is an item that shows the current task of the battery charger.

Various values are shown:

- The first is the working voltage of the solar panel read on the datalogger input terminal block. If the power line between the cell and the datalogger is long and the transited current is high, it is possible to detect a significant voltage drop. The datalogger shows the voltage seen from the datalogger.
- The second is the charge voltage of the battery on the datalogger output terminal block. This voltage depends on the battery and the external temperature.
- The third is the output power from the battery charger, obtained from the product between the battery voltage and the current delivered by the power supply.
- Instead, in the second row we have as a first indication of the tracking direction of the algorithm followed by the operating point and the current supplied, the latter also including the consumption of the datalogger itself.

12.8 Record layout

The values are stored in binary records and consecutively written in daily files with a REC extension. They can be read and translated into ASCII files using an external programme.

Each record is a fixed length of 32 bytes and is written in little-endian format, i.e. where the least significant byte comes first in the sequence.

There are 3 types of record that start with 4 identical fields. One of these is the record type and allows to distinguish the contents:

Normal record	Contains a full record of maximums, minimums and standard deviation.
Rain intensity record	Contains 5 minutes of intensity, i.e. 5 consecutive data points.
Alarm record	Contains an exceeded alarm threshold.

Each data record is derived from a calculation that is subject to 2 times:

DTC	Delta T sampling in seconds, i.e. how often to start the acquisition to extract a single elementary measurement.
DTR	Delta T recording in seconds, i.e. how often to record a calculation of elementary data in the internal memory (DTC is a submultiple of DTR).

Each sensor has a processing "Window" that determines which values should be recorded:

Most recent	most recent data acquired
Average	mathematical average

- Maximum** maximum value of samples acquired
- Minimum** minimum value of samples acquired
- DevST** standard deviation of samples acquired.

12.8.1 Normal record

Offset	Length	Type	Definition
0	4	Unsigned int 32	Time, instant of processing Expressed in seconds starting from 01/01/2000 at 00:00:00
4	2	Unsigned int 16	Identification of the measure
6	1	Unsigned int 8	Record type (0..2) 0=Normal
7	1	Unsigned int 8	Number of significant decimals
8	4	Float 32	Most recent value acquired -9998 not provided by the processing window -9999 the data cannot be calculated
12	4	Float 32	Average value -9998 not provided by the processing window -9999 the data cannot be calculated
16	4	Float 32	Standard deviation -9998 not provided by the processing window -9999 the data cannot be calculated
20	4	Float 32	Maximum value -9998 not provided by the processing window -9999 the data cannot be calculated
24	4	Float 32	Minimum value -9998 not provided by the processing window -9999 the data cannot be calculated
28	2	Unsigned int 16	Maximum time in minutes (0..1439)
30	2	Unsigned int 16	Minimum time in minutes (0..1439)

12.8.2 Rain intensity record

Rain intensity has a temporal resolution per minute, is expressed in mm/h and represents the quantity of rainfall in one minute. Since a tipping rain gauge measures a discreet quantity of water, at low intensities tipping can occur after several minutes. Since the minimum intensity is 2 mm/h, at worst the calculation can be performed with a delay of 6 minutes. To always perform consistent and repetitive calculations, rainfall intensity data is recorded every 5 minutes, always contains 5 values and always refers to past and ended events. The record contains the intensities from 6 to 10 minutes before the time of processing.

Offset	Length	Type	Definition
0	4	Unsigned int 32	Time, instant of processing Expressed in seconds starting from 01/01/2000 at 00:00:00
4	2	Unsigned int 16	Identification of the measure
6	1	Unsigned int 8	Record type (0..2) 1=Rain intensity
7	1	Unsigned int 8	Number of significant decimals
8	4	Float 32	Rain intensity of 10 minutes before

12	4	Float 32	Rain intensity of 9 minutes before
16	4	Float 32	Rain intensity of 8 minutes before
20	4	Float 32	Rain intensity of 7 minutes before
24	4	Float 32	Rain intensity of 6 minutes before
28	4	Unsigned int 32	Not used

12.8.3 Alarm record

An alarm record is generated when at least one of the following parameters is set and exceeded.

- AllSup** If set, this parameter is the numerical value to be considered as an upper alarm level.
- AttSup** If set, this parameter is the numerical value to be considered as a higher level of attention. Has lower priority than the upper and lower alarm.
- AttInf** If set, this parameter is the numerical value to be considered as a lower level of attention. Has lower priority than the upper and lower alarm and the higher attention level.
- AllInf** If set, this parameter is the numerical value to be considered as a lower alarm level. Has lower priority than the upper alarm.

Offset	Length	Type	Definition
0	4	Unsigned int 32	Time, instant of processing Expressed in seconds starting from 01/01/2000 at 00:00:00
4	2	Unsigned int 16	Identification of the measure (bit14..bit0) exclude bit15 Signalling of alarm (bit15) always at 1
6	1	Unsigned int 8	Record type (0..2) 2=Alarm
7	1	Unsigned int 8	Number of significant decimals
8	4	Float 32	Acquired value that generated the alarm
12	4	Float 32	Alarm threshold exceeded, attention, alarm
16	4	Unsigned int 32	Reason for the alarm 0 = alarm stopped 1 = upper attention exceeded 2 = upper alarm exceeded -1 = lower attention exceeded -2 = lower alarm exceeded
20	4	Unsigned int 32	Not used
24	4	Unsigned int 32	Not used
28	4	Unsigned int 32	Not used

12.9 Rainfall record

The pluviometric event specifies the time, in seconds and milliseconds, in which the tilting of the rain gauge was recorded. Rain gauge time events are stored in binary records and written consecutively in daily files with an .evt extension. Rainfall events are also written to memory in Little-endian mode.

Each event has a fixed size of 6 bytes and consists of the following fields:

Offset	Length	Tipo	Meaning
0	4	Unsigned int 32	Time of the pluviometric event expressed in number of seconds from 01/01/2000 at 00:00:00

4	2	Unsigned int 16	Time of the rainfall event in milliseconds.
---	---	-----------------	---

The recording of rainfall events must be accompanied by the sending of the data themselves through a rain path (see chapter 2.3.1.1 Type field). You can find a description of this route in the document "s043-d Rain Track.docx"

12.10 Meaning of LOG debug

The LOG is a system which allows to interpret the operation of the Micro SUM.

At system start-up COM1 is automatically activated at the speed of 38400, n, 8, 1, to provide the first messages about the operation.

```

Micro SUM SIAP+MICROS S.p.A.
HW=1234 SN=23 FW=0.2.22
Event reset          47  found
Event new config     18  found
Event erase bank 1   0   found
Event erase bank 2    5   found
Event copy b2 >> b1 0   found
Event hours          12  found
Event format nor      1   found
Event modem on       35  found
Event modem err      31  found
Event set time        1   found
Event ChkDsk         3   found
From SuperChkdsk     0   days
Event lost           2   found
BFB2 disabled, normal start
Mount NOR FLASH on 0:/
Now is 25/09/19 17:44:08
Mount SD FLASH off 1:/
SD_CARD OFF
Configuration loaded, Area=3916/10240 Nodes=35/100
UtilityTask Init
Activate Modbus ID=44 on COM1 with baudrate=38400
Activate Debug level=1 on COM1 with modbus
  
```

The Micro SUM datalogger starts, shows a series of characteristic parameters, the count of events, initialises the internal data drive and shows the time.

The configuration that must be used resides on the internal drive. It is loaded showing how much area it occupies and how many nodes are used. Initialise the first process called "UtilityTask" which controls and activates all communication channels and the debug channel to be used.

If the programmed debug channel in the configuration is different, or if the speed of use is different or if it has been disabled, the change is made and now followed.

```

AcquisitionsTask Init
DisplayTask Init
TransmissionsTask Init
Schedulare Start
-----
TransmissionsTask Start with 0 jobs
JobFromAD "All AnDiff" activate with 4 phase
AcquisitionsTask Start with 1 jobs and 4/100 interim
DisplayTask Start
UtilityTask Start
TrackMPPT no sun, in the middle
TrackMPPT Vsolar=0V Vbatt=13.1V Icharge=0.389A Power=0W Point=128
JobFromAD "All AnDiff" start polling (25/09/19 17:44:12)
PhaseAnalog "Analog 1" value=-89.7261
PhaseAnalog "Analog 2" value=-11.0294
PhaseAnalog "Analog 3" value=123.4107
PhaseAnalog "Analog 4" value=185.1161
JobFromAD "All AnDiff" end polling
  
```

The LOG continues showing the initialisation of the other processes called “AcquisitionTask”, “DisplayTask”, “TransmissionsTask” and the start of the FreeRTOS operating system “Schedulare Start”. From this moment the datalogger starts the **Tasks** which in turn start the **Jobs** and then the **Phases** of which it is composed and programmed.

```

TrackMPPT OldPower=0.1W continue down
TrackMPPT Vsolar=16.7V Vbatt=12.9V Icharge=0.016A Power=0.2W Point=129
JobFromAD "Sensori diagnostici" start polling (25/09/19 17:14:00)
PhaseInternal "Batteria [V]" value=13.0054
PhaseInternal "Consumo [mA]" value=32.4653
PhaseInternal "Pannello solare [V]" value=16.6940
PhaseInternal "In carica [mA]" value=13.3792
JobFromAD "Sensori diagnostici" end polling
JobFromSerial "Sensori Modbus COM3" start polling on COM3 (25/09/19 17:14:00)
PhaseModbus "Temp.aria [oC]" request >>> COM3
JobFromAD "Vento naturale" start polling (25/09/19 17:14:00)
PhaseDigital "VV [m/s]" value=0.6892
JobFromSerial "Sensori SDI-12" start polling on COM4 (25/09/19 17:14:00)
PhaseSDI12 "Piranometro [W/mq]" request aMC! >>> COM4
PhaseAnalog "DV [o]" value=144.2807
JobFromAD "Vento naturale" end polling
PhaseModbus "Temp.aria [oC]" receive <<< COM3
PhaseModbus "Temp.aria [oC]" value=18.4389
PhaseModbus "Umidità aria [%]" value=80.5364
  
```

```

PhaseModbus "Barometro [hPa]" request >>> COM3
PhaseModbus "Barometro [hPa]" receive <<< COM3
PhaseModbus "Barometro [hPa]" value=1002.2286
PhaseModbus "Temp SHT85 [oC]" request >>> COM3
PhaseSDI12 "Piranometro [W/mq]" receive <<< COM4
PhaseSDI12 "Piranometro [W/mq]" measurement immediately available
PhaseSDI12 "Piranometro [W/mq]" request aD0! >>> COM4
PhaseModbus "Temp SHT85 [oC]" receive <<< COM3
PhaseModbus "Temp SHT85 [oC]" value=18.4821
PhaseModbus "Umid SHT85 [%]" value=80.3341
PhaseModbus "WinSon VV [m/s]" request >>> COM3
JobFromAD "Sensori A/D" start polling (25/09/19 17:14:01)
PhaseSDI12 "Piranometro [W/mq]" receive <<< COM4
PhaseSDI12 "Piranometro [W/mq]" value=28.1000
PhaseSDI12 "Piranometro [W/mq]" all received, OK
JobFromSerial "Sensori SDI-12" end polling
PhaseModbus "WinSon VV [m/s]" receive <<< COM3
PhaseModbus "WinSon VV [m/s]" value=0.2347
PhaseModbus "WinSon DV [o]" value=130.0000
PhaseModbus "WinSon T [oC]" value=18.9263
JobFromSerial "Sensori Modbus COM3" end polling
PhaseAnalog "Temp.aria PT [oC]" value=18.1369
JobFromAD "Sensori A/D" end polling
JobFromAD "Sensori A/D Radar" start polling (25/09/19 17:14:02)
PhaseAnalog "Livello [m]" value=2.6453
JobFromAD "Sensori A/D Radar" end polling
    
```

Each row starts with the name of the Job or Phase to be performed.

The LOG can be variously detailed. One of the configuration parameters is the level of detail you want to have. From the Advanced menu it is possible to increase or decrease this value at any time. Moreover, since the activities are carried out in parallel, it is possible to filter and ignore those that are not desired.

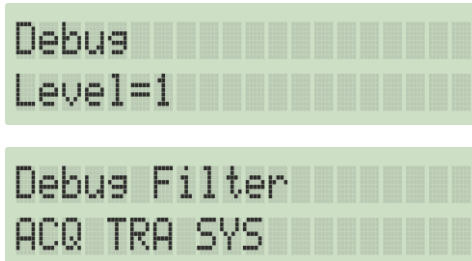

By connecting a PC to the USB, a debug channel is automatically created and can be controlled and shown with a terminal emulator. Obviously the whole previously shown start and initialisation phase cannot be followed.

From a channel programmed with Modbus protocol and from USB, through the DAK programme, it is possible to send both a new configuration and a new programme. What follows is what happens on the LOG when sending a new configuration:

```
Modbus receive 9 on USB
Modbus receive 1012 on USB
Modbus receive 1012 on USB
Modbus receive 1012 on USB
Modbus receive 1012 on USB
Modbus receive 1012 on USB
TrackMPPT no sun, in the middle
TrackMPPT Vsolar=0V Vbatt=13.0V Icharge=0.158A Power=0W Point=128
Modbus receive 1012 on USB
Modbus receive 84 on USB
Modbus receive 18 on USB
XML configuration file received, now reboot

Micro SUM SIAP+MICROS S.p.A.
HW=1234 SN=23 FW=0.2.22
Event reset          48 found
Event new config     18 found
Event erase bank 1   0 found
Event erase bank 2   5 found
Event copy b2 >> b1 0 found
Event hours          13 found
Event format nor     1 found
Event modem on       35 found
Event modem err      31 found
Event set time       1 found
Event ChkDsk         3 found
From SuperChkdsk    0 days
Event lost           2 found
BFB2 disabled, normal start
Mount NOR FLASH on 0:/
Now is 25/09/19 18:37:59
CNF Remarks
CNF Parameters
CNF Identity
CNF ChModbus
CNF ChModem
CNF ChDebug
CNF Password
CNF Acquisitions
CNF FromSerial
CNF Modbus
```

```
CNF Modbus
CNF FromAD
CNF Internal
CNF Internal
CNF Internal
CNF Internal
CNF FromAD
CNF Analog
CNF Analog
CNF Analog
CNF Analog
CNF Analog
CNF Analog
CNF Analog
CNF Analog
CNF Analog
CNF Analog
CNF FromAD
CNF Analog
CNF Analog
CNF Analog
CNF Analog
CNF Processings
CNF Controls
CNF Storages
CNF Transmissions
CNF Display
CONF Area=3916/10240 Nodes=35/100
Mount SD FLASH off 1:/
SD_CARD OFF
Configuration loaded, Area=3916/10240 Nodes=35/100
```

Note reception of the new configuration divided into packets, the restart of the datalogger, the translation of the XML configuration into the internal format and the start of the datalogger.

Instead, what follows is what happens on the LOG when sending a new programme

```
Modbus receive 15 on USB
UpdateInit
Erase BANK 2
.....
Done erase BANK 2
Modbus receive 889 on USB
UpdateReceive 1/11674
UpdateReceive 21/11674
```

```
.....  
Modbus receive 917 on USB  
UpdateReceive 11641/11674  
Modbus receive 575 on USB  
UpdateReceive 11661/11674  
UpdateReceive receive all UPDATE, now reboot  
UpdateReboot  
.....  
Firmware received correctly, active update  
.....  
Set BFB2  
Reboot micro  
  
Micro SUM SIAP+MICROS S.p.A.  
HW=1234 SN=23 FW=0.2.22  
Event reset          49 found  
Event new config     19 found  
Event erase bank 1   0 found  
Event erase bank 2   6 found  
Event copy b2 >> b1  0 found  
Event hours          13 found  
Event format nor     1 found  
Event modem on       35 found  
Event modem err      31 found  
Event set time       1 found  
Event ChkDsk         3 found  
From SuperChkdsk    0 days  
Event lost           2 found  
BFB2 enabled, start firmware replacement  
Erase BANK 1  
Done erase BANK 1  
Copy on BANK 1  
.....  
.....  
.....  
.....  
Done copy on BANK 1  
Cancel BFB2  
Reboot micro
```

```

Micro SUM SIAP+MICROS S.p.A.
HW=1234 SN=23 FW=0.2.22
Event reset          50 found
Event new config     19 found
Event erase bank 1   1 found
Event erase bank 2   6 found
Event copy b2 >> b1 1 found
Event hours          13 found
Event format nor     1 found
Event modem on       35 found
Event modem err      31 found
Event set time       1 found
Event ChkDsk         3 found
From SuperChkdsk    0 days
Event lost           2 found
BFB2 disabled, normal start
Mount NOR FLASH on 0:/
Now is 25/09/19 18:45:29
CNF Remarks
CNF Parameters
.....
  
```

The programme is divided into two zones called BANK1 and BANK2. The programme resides in BANK1 while the new programme is received in BANK2. Note the arrival of the first command to prepare for the update with the cancellation of BANK2, the arrival of all the programme packets, the start of BFB2 (Boot from bank 2) and the consequent restart of the micro.

When restarted, the datalogger will execute the deletion of BANK1 and the copying from BANK2 to BANK1 and the consequent restart. These operations are all automatic and secure.

At startup and every minute, all events are displayed as follow:

- Running= information on how the datalogger works
- Reset = number of resets performed by the Micro SUM,
- Hours= number of total operating hours,
- EvLost= number of internal events lost and not served due to system flooding problems.

Config= information about the loaded configuration

- New= number of configurations received and translated,
- F_NOR= number of NOR internal disk formatting.

Firmware: Firmware Update Information

- ErsB1= number of firmware bank cancellations 1,

- ErsB2= number of firmware bank cancellations 2,
- Copy= number of copies of the firmware bank 2 in 1.

Modem: Information about using the internal xG modem

- On= number of ignitions of the internal modem,
- Err= number of errors detected,,
- Rssi= last value in dBm detected by the modem.

Modbus RX: information on queries to Micro SUM

- Asc= number of messages received in ascii FN65 format,
- Bin= number of messages received in binary format FN67,
- Other= number of messages received in other formats.

SetTime: information about updating watch

- Ntp= hourly update number via website,
- Other= time update number via serial commands.

CheckDisk: information about checking the internal disk

- N= number of checks of the minimum free space on the internal disk, is performed at half-night,
- Super= the number of days since the internal disk was last formatted. When 100 is reached, if SD memory is present, a backup and re-formatting of the disk is performed.

Power: situation of the supplied supplies

- COM2= power supplied on pin22,
- COM3= power supplied on pin27,
- SDI12= power supplied on pin47,
- AN1= power supplied on pin36,
- AN2= power supplied on pin06.

Stack free: information about using the stack, the values all start from 1000 and over time it is reduced, it is dangerous if they get too close to zero,

- ACQ= the quantity of free memory still available for the capture process,
- TRA= the quantity of free memory still available for the transmission process.
- Disp= the quantity of free memory still available for the display management process.
- Util= the quantity of free memory still available for the utility process.

13 DAK software for management of MicroSUM datalogger

This chapter describes how to use DAK software to configure and work with MicroSUM datalogger.

13.1 Installation

Before proceeding with DAK installation, please check the PC has this minimum System requirement:

- **Pentium** or later
- **RAM 16 Mb** or more of RAM
- **1 Gb Hard Drive** or more
- **CD ROM player**
- O.S. **Microsoft Windows** 95, 98, ME, Win NT, Windows 2000, XP, Vista, Windows 7, Windows 10, Windows 11

Follow the instructions below to install the software:

- Insert DAK CD ROM into the player
- From Task Bar, click on *Start | Run...*
- Digit **D:\Setup.exe** in the text box or thumb the CD ROM
- Click **OK** button
- Follow the instruction shown during guided installation process until the end

13.2 Overview

To work with MicroSUM datalogger, make sure that DAK is set to the correct target. In the menu bar select *Tools/Target/microDA (MicroSUM) Datalogger*. If current target is different, a pop-up will ask the user to restart the program in order for the target type change to take effect.

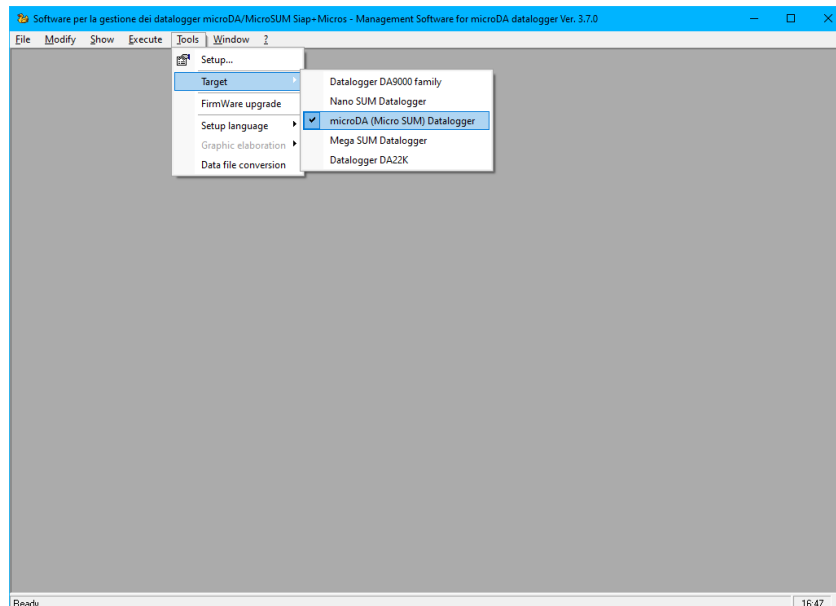

Figure 13.1: target selection.

Figure 13.2 shows the user interface. In details:

1. Selected target and program version.

2. Menu bar.
3. Name of the configuration file.
4. Configuration tree.
5. List of configuration fields of the selected feature.
6. Description of selected feature.

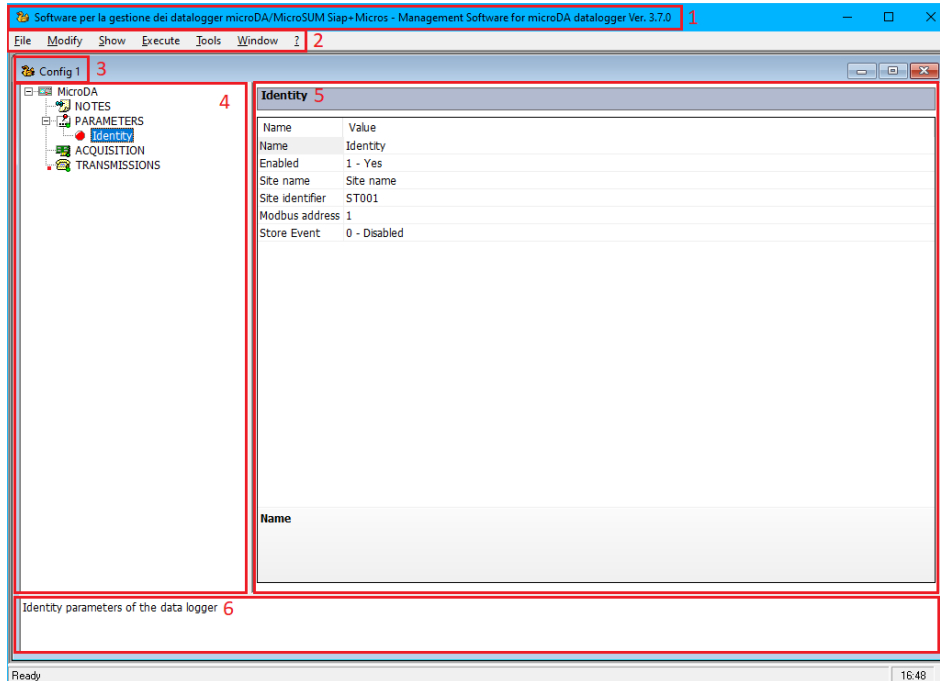

Figure 13.2: user interface.

13.3 Build a new configuration

Scheduled activities and functionalities of the MicroSUM datalogger are defined in a configuration file saved in XML format (eXtensible Markup Language).

To create a new configuration from scratch, select *File/New...* from menu bar. A new window will open with the temporary name "Config 1" (the name can be changed later).

As shown in Figure 13.2 MicroSUM has 4 main sections:

- Notes: allows the user to add notes about the configuration.
- Parameters: defines identity, modem, numeric parameters and how some serial ports are used.
- Acquisition: defines acquisition, processing and storage activities.
- Transmissions: defines data transmission activities.

For a detailed description of all elements of each section and their configurable fields see Chapter 2.

To add an entry, select the section of interest:

- From *Modify* menu select *Insert*, a list of all elements available for that section will appear (Figure 13.3 right).

- Alternatively, right-click on the section and select *Insert* (Figure 13.3 left).

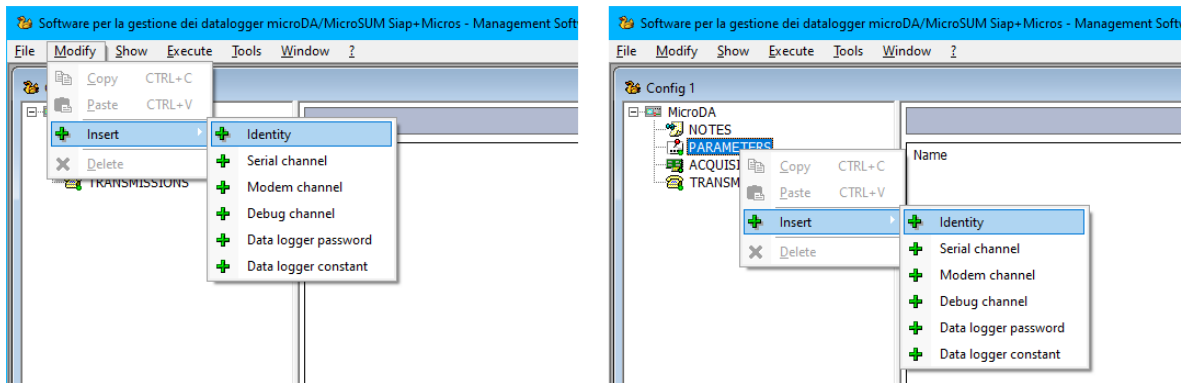

Figure 13.3: insert an entry from Parameters section.

For example, Figure 13.3 shows how to insert the identity of the datalogger from Parameters section and Figure 13.4 shows how the configuration tree will appear after the insertion of the identity. Please note that the configuration fields are listed on the adjacent window where the user can change their values.

To change a value, double-click on the corresponding box. The cursor will be positioned inside the box and the user can move through characters and change the value. Note that some configuration fields have a default value. These can be of 3 different types:

- Character string
- Number
- Enumerated type selectable from a drop-down menu.

Numeric values have limits. If you enter a number outside the allowed range of values, you will be warned with a pop-up.

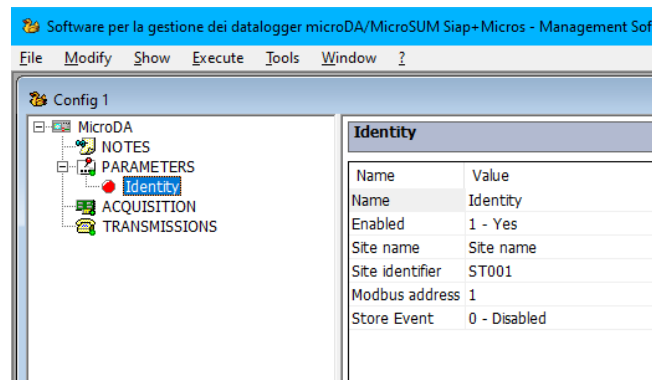

Figure 13.4: example of configurable fields of the datalogger identity.

To delete an entry, select it from configuration tree:

- From *Modify* menu, select *Delete*.
- Alternatively, right-click on the entry and select *Delete*.

From Acquisition and Transmissions sections user can insert activities composed of one or more phases. For example, to add a serial data acquisition (RS232 or RS485) from a sensor in Modbus protocol (see Figure 13.6):

- Insert a “Serial sensors” acquisition activity.

- From serial acquisition add the measurements read from a Modbus sensor.

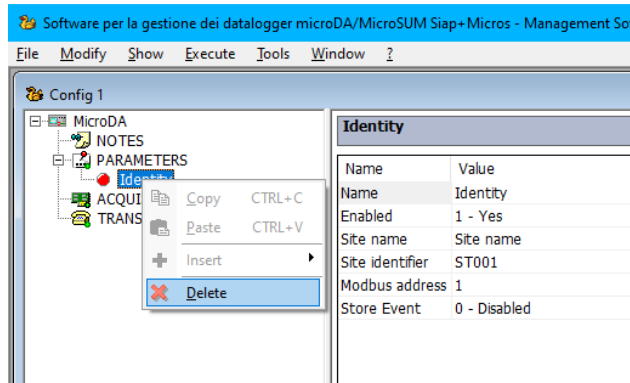

Figure 13.5: delete an entry from configuration.

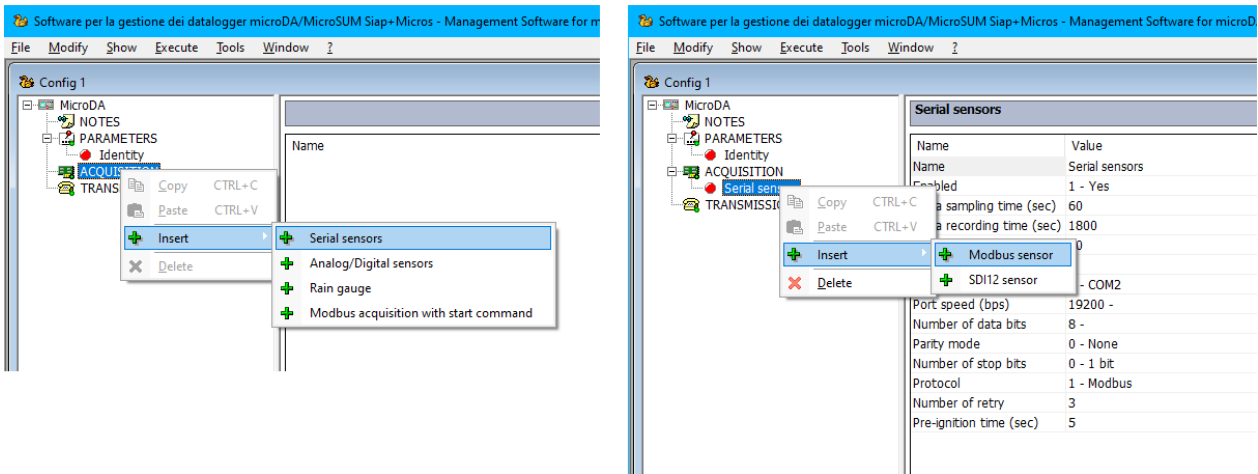

Figure 13.6: insert a serial acquisition from Modbus sensor.

Similarly, to add a data transmission to an FTP server (see Figure 13.7):

- Insert an FTP transmission activity.
- From FTP transmission add the server phase.

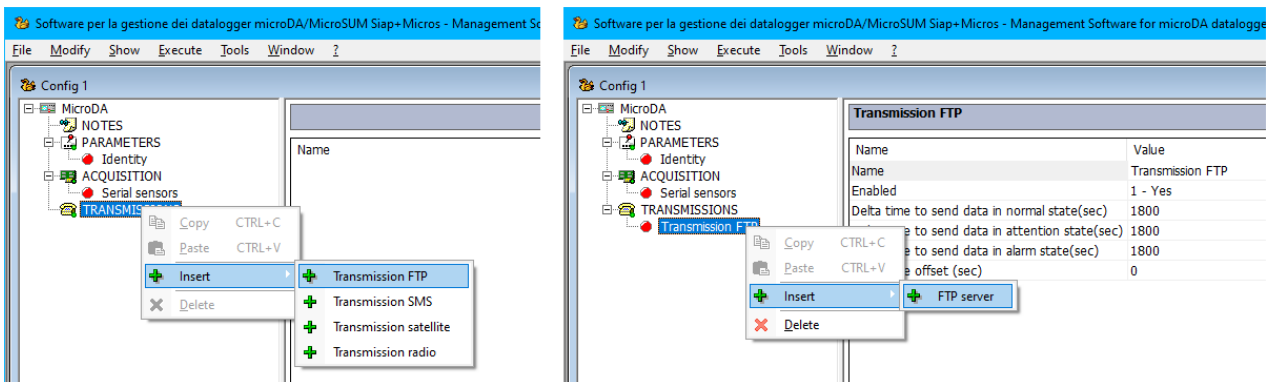

Figure 13.7: insert an FTP transmission.

13.4 Save configuration file

From *File* menu, select *Save* or *Save as...*, a dialog box will open allowing the user to define the name of the XML file and select the directory where file will be saved.

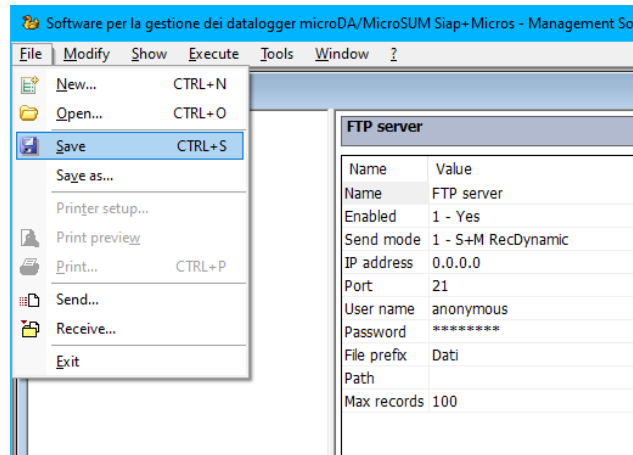

Figure 13.8: save configuration file.

13.5 Open an XML configuration file

From *File* menu select *Open...*, a dialog box will open allowing the user to browse the filesystem and select an XML file. Once opened, the user can edit every part of the configuration, insert new entries and delete existing ones as described in the previous chapters. Pay attention that if a file is not well formatted, DAK will not be able to read all sections of the configuration correctly.

If multiple configuration files are opened at the same time, the windows will overlap and the one corresponding to the last opened file will be positioned at the top of the list. Select *Window* from bar menu and click *Tile*, *Arrange horizontal* or *Arrange vertical* to arrange the windows more clearly.

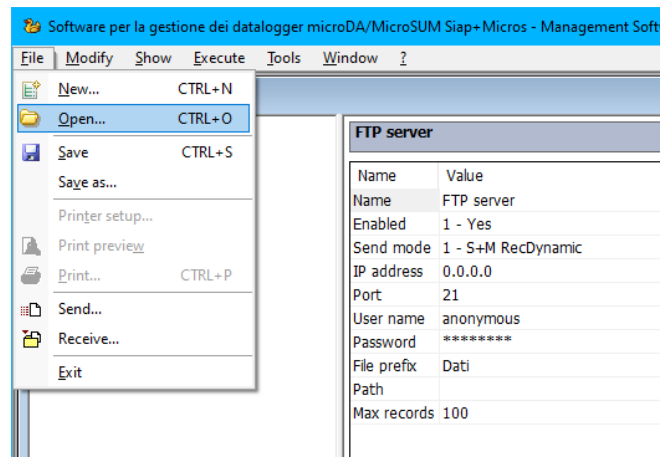

Figure 13.9: open a configuration file.

13.6 Setting up communications with the datalogger

There are two ways to set up a communication between the datalogger and a PC:

- Using an USB cable connected to the micro-USB connector of the datalogger.

- Using a serial port. In this case the user needs to configure a serial channel from Parameters section along with the serial port settings (see Figure 13.10). To connect the datalogger to the PC, the user must use an USB-RS232 or USB-RS485 converter, depending on the chosen serial port.

After that, the user needs to specify the COM port of the PC to which the datalogger is connected from *Tool/Settings* menu. A window will open allowing the user to select the COM port and specify the serial port settings (baudrate, number of data bits, parity and stop bits). If communication is set up via USB cable, serial port settings are useless since communication is managed by USB protocol. If a communication via serial port is established, serial port settings must be set according to the serial channel configuration. Select the COM port, click *Apply* and then *OK*.

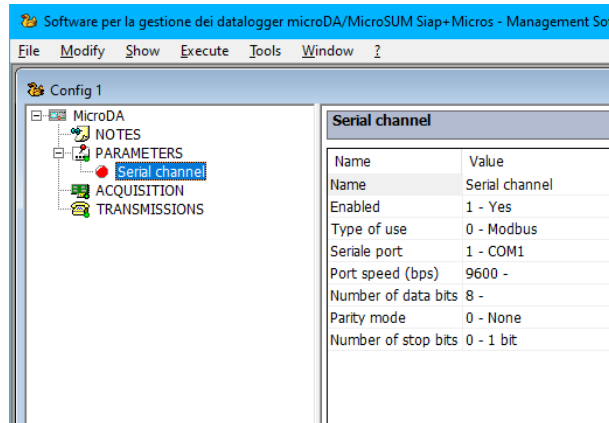

Figure 13.10: configuration of a serial channel.

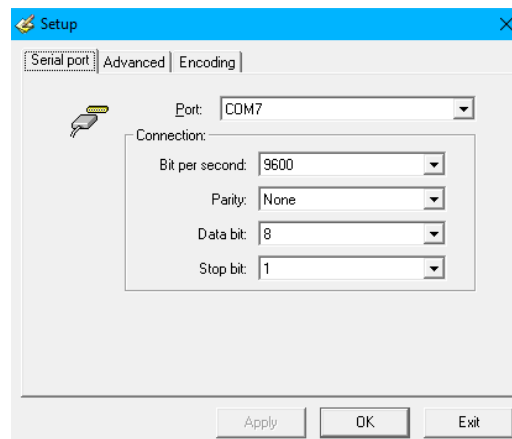

Figure 13.11: setup window of the serial port connected to the datalogger.

All the operations described in the following chapters assume that there is a communication between the datalogger and a PC.

13.7 Upload and download a configuration file

To read the configuration from the datalogger select *File* from menu bar and click *Receive...*, then a communication between datalogger and DAK will start to download the XML file. A progress bar is used to give the user an indication of the progress of the operation. At the end of the operation a new window will open showing the configuration tree with a name automatically assigned by DAK.

Similarly, to send a new configuration to the datalogger select *File* and click *Send...*, then a communication will start to send the opened XML file. Upon completion, the datalogger will restart and load the new configuration.

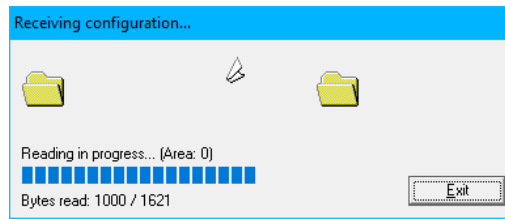

Figure 13.12: reading a configuration from the datalogger.

13.8 Checking of datalogger data and operation

The following chapters explain the other functionalities provided by DAK to monitor the datalogger data and its operating status.

13.8.1 Reading station ID

From *Execute* menu click *Station ID*, a window will open that allows the user to read datalogger station ID and storage ID. Click *Request* to send the request and read the two IDs.

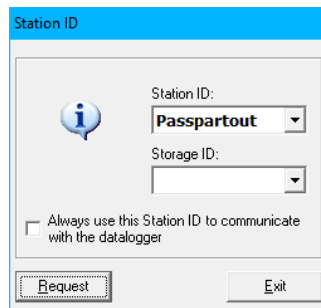

Figure 13.13: reading station ID and storage ID.

13.8.2 Reading parameters

Select *Execute* from menu bar and click *Parameters* to read the numeric parameters from datalogger configuration. A window will open to list the parameters along with their name, unit of measurements and value. For example, Figure 13.14 shows a parameter named *Offset* and value equal to 10m.

To change a parameter, follow the instructions below:

- Click the value box to place the cursor inside it.
- Insert a new value and press *Enter*. After that, the box value will be highlighted in light blue (Figure 13.15).
- Click *Send* button to send the new parameter value to the datalogger. After that, the parameters will be automatically read again and refreshed on the dialog box.

At any time, pressing the *Refresh* button allows the user to read the parameters again.

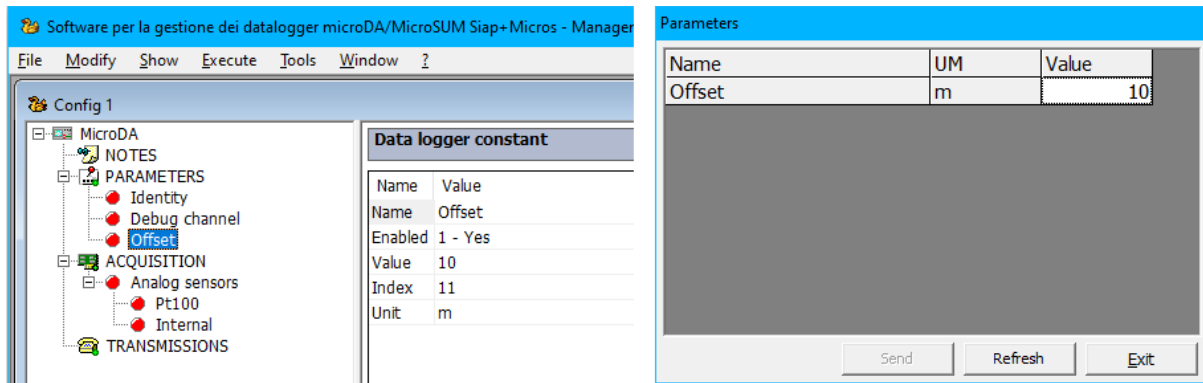

Figure 13.14: reading datalogger parameters.

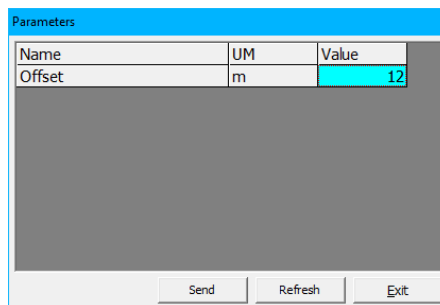

Figure 13.15: modifying a datalogger parameter.

13.8.3 Instant data request

Select *Execute* from menu bar and click *Instant data request*. A window will open that allows the user to send requests to the datalogger to read the instantaneous value of the configured measures. Click *Request* button and the window will be filled with the latest values acquired by sensors. Measurement name, value and status are displayed. For example, in Figure 13.16 two measures are shown, a temperature data from Pt100 (21.4°C) and the battery voltage (12.3V).

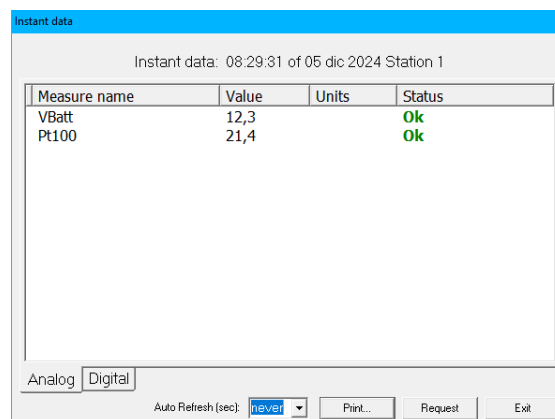

Figure 13.16: instant data.

By setting the value of “Auto refresh” from drop-down menu, instant data requests will be sent periodically to the datalogger at the chosen time. This is useful if you want to monitor the values acquired by sensors without having to click *Request* button every time.

13.8.4 Synchronize clock

Select *Execute* from menu bar and click *Synchronize clock*. A window will open that allows the user to set date and time of the datalogger. Keep “Synchronize with PC clock” option checked to use your PC time for clock synchronization. Otherwise, uncheck the option and manually set date and time. Finally, click *Send* button to send a command to set the new date and time to the datalogger. “Send reset datalogger” option appends a command to restart the datalogger after clock synchronization (Figure 13.17).

13.8.5 Custom commands

Select *Execute* from menu bar and click *Custom commands*. A window will open where user can manually insert a command to send to the datalogger (Figure 13.18). Please note that the datalogger responds to the ASCII commands described in Chapter 6.2.

The first line is a one-line text editor where user can insert the command. The second line shows the last command sent to the datalogger. It's a drop-down menu listing the latest commands. *Erase* button deletes the history of the latest commands. In the Answer window, the datalogger response is printed. The response time and the number of bytes will also be reported after the response.

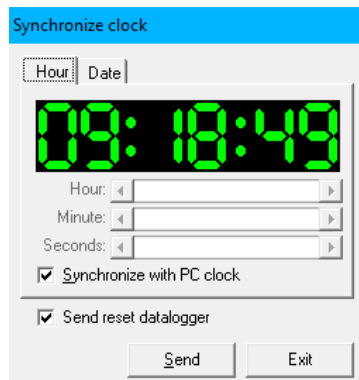

Figure 13.17: setting date and time of the datalogger.

There are 4 buttons at the bottom right of the window:

- Two arrow buttons to set the period in seconds to send the command. By default, the value is OFF, that is disabled, so commands must be manually sent by user.
- *Reset* to send a command to restart the datalogger.
- *Send* to send a command.
- *Exit* to exit the window.

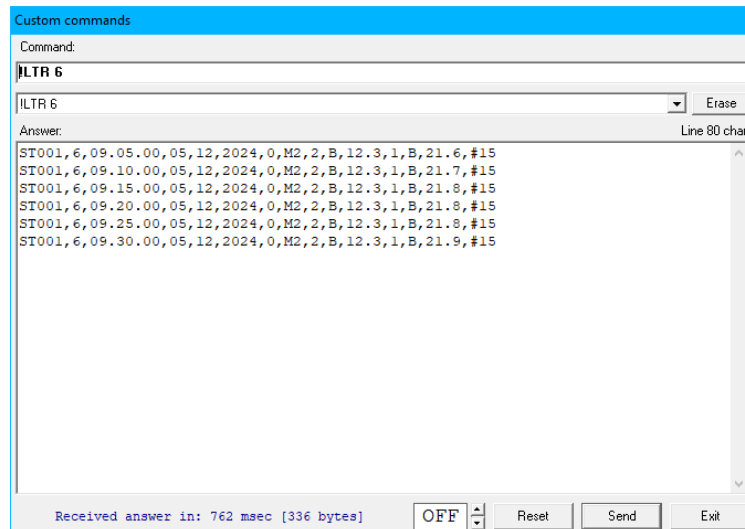

Figure 13.18: example of custom command.

13.8.6 Display

MicroSUM datalogger is equipped with a 20x2 character LCD module that can be emulated by DAK. Select *Execute* from menu bar and click *Display* to open a window showing a graphic display and 5 buttons. You can scroll and view all the menus of the display using the four arrow buttons and the central button. There are also other 3 buttons:

- *H* to go back to the first screen of the display.
- *Refresh* to refresh current screen.
- *Exit* to exit.

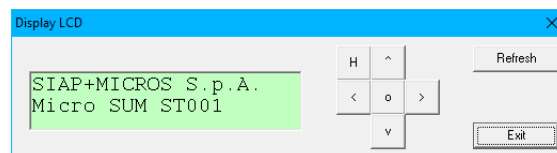

Figure 13.19: display and joystick emulator.

13.8.7 Data file conversion

MicroSUM datalogger saves data to files with .rec extension in binary format. To convert a data file downloaded from datalogger memory into text format, select *Tools* from menu bar and click *Data file conversion*. A dialog box will open that allows the user to browse the filesystem and select a data file with .rec extension. The user will then be asked to enter the station ID (by default 1). Finally, click *OK* to generate the file with records written in Siap+Micros text format. The output file will have the same name as the input file and extension .txt. This procedure allows to convert one binary file at a time.

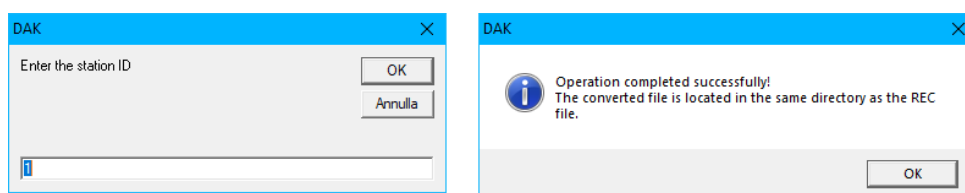

Figure 13.20: data file conversion.

13.9 Firmware upgrade

Select *Tool* from menu bar and click *FirmWare upgrade*. A window will open showing the serial number (SN), hardware ID (HW) of the board, firmware version (SW) and internal modem data (only if a transmission activity that uses the internal modem has been defined in configuration).

To start a firmware update you need a binary file with .hex extension released by Siap+Micros. Click *Commands/Load program* to open a dialog box to browse the filesystem and select a .hex file. After that, the update procedure will start. The status of the operation will be indicated by a progress bar.

At the end of the operation the datalogger will restart and load the new firmware. To verify the actual upgrade, just click *File/Program information* and check the firmware version number. To exit from programming window, click *File/Exit*.

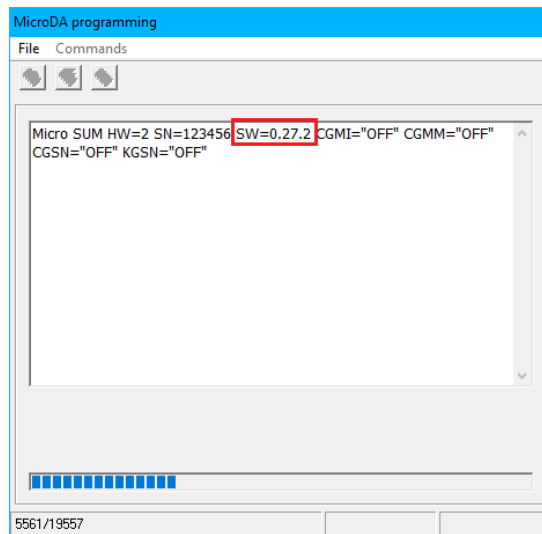

Figure 13.21: firmware update. The red rectangle highlights the firmware version.

13.10 Language setting

Click *Tools/Setup language* to select a different language. If you change the language, DAK will close and the language setting will be updated at the next start.