

e022 DA22KE

Data Acquisition Unit



User Manual
 DA22K and DA22KE Data Loggers
 Version 03 - Firmware v.2.3.1

SIAP+MICROS

TABLE OF CONTENTS

1	Precautions and Safety Measures	5
1.1	Intended Use.....	5
1.2	Warnings.....	5
1.3	Transport.....	5
1.4	Unpacking	6
1.5	Safe Power-On Procedure.....	6
1.6	During operation.....	6
1.7	Storage	7
1.8	Maintenance	7
1.8.1	Cleaning the Instrument	7
1.8.2	s and electrical line protection	7
2	hardware and connections.....	8
2.1	Processing and storage electronics enclosure	8
2.2	Acquisition electronics and power management enclosure.....	10
2.3	Power Supplies	12
2.4	PT100 Inputs.....	13
2.5	Analog Inputs	14
2.5.1	Analog inputs on a 6-pin connector	14
2.5.2	Analog inputs on 3-pin connectors.....	15
2.5.3	Analog Inputs on 4-Pin Connectors	15
2.5.4	Analog Inputs Configurable for 4–20 mA	15
2.6	Digital Inputs	16
2.7	Digital Outputs.....	17
2.8	Connectivity	17
2.8.1	RS-232 serial interfaces with the following specifications: COM1, COM4, COM8	17
2.8.2	RS-485 serial interfaces: COM2, COM6, COM7	18
2.8.3	RS-232 and RS-485 hybrid serial interfaces: COM3.....	19
2.8.4	SDI-12 Interfaces: COM5, COM9	19
2.8.5	Network Interface.....	19
2.8.6	USB Host Interfaces.....	20
2.8.7	USB Slave Interfaces	20
2.9	External storage devices and display.....	20
3	User Guide and Configuration	21
3.1	Operating System.....	21
3.1.1	Startup.....	22
3.1.2	Remote connection	23
3.1.3	Network Configuration.....	24
3.1.4	Modem Configuration.....	25

3.1.5	VPN Client	27
3.1.6	FTP Server	28
3.1.7	Clock Setup	29
3.2	Display interface	30
3.2.1	Home Screen	30
3.2.2	User Login	31
3.2.3	Station Information	32
3.2.4	Current Measurements	33
3.2.5	DAT s and history	34
3.2.6	Datalogger Status	36
3.2.7	Service Functions	38
3.2.8	Paramet s	39
3.2.9	Configuration	40
3.2.10	Application firmware	42
3.2.11	Maintenance	44
3.2.12	Log	45
3.2.13	System	46
3.2.14	System Information	46
3.2.15	Date & Time	47
3.2.16	Network	48
3.2.17	Reboot	48
3.3	Data Logger Configuration	49
3.3.1	tialization File	49
3.3.2	Configuration file	53
3.3.3	Main cycle and secondary processes	54
3.3.4	User parameters	55
3.3.5	tion of measurements	56
3.3.6	Processing Functions	58
3.3.7	Control Section	62
3.3.8	Data logging	66
3.3.9	Data backup	69
3.3.10	Record trace	70
3.3.11	I Data Transmission	71
3.3.12	Display	76
3.3.13	Variables, e , and operators	77
3.4	Command interpretation	79
3.4.1	Modbus protocol specification	79
3.4.2	General commands	80
3.4.3	, variable (), and parameter management	81
3.4.4	Archive management	81

3.4.5	Output commands.....	84
4	Regulations	85
4.1	Safety Standards.....	85
4.2	EMC.....	85
5	Environmental Conditions for Use.....	86
6	Revision History	87
7	EU Declaration of Conformity	88

1 Precautions and Safety Measures

The DA22K is a measuring instrument that allows for the acquisition, processing, and storage of electrical quantities. It consists of two parts: a CPU module for data processing and storage, and a base module for acquiring physical measurements and managing the power supply for the entire system.

This equipment complies with the requirements of the Low Voltage Directive (LVD) 2014/35/EU and the Electromagnetic Compatibility (EMC) Directive 2014/30/EU.

For operator safety, it is necessary to follow the procedures described in this manual and read all notes carefully.

1.1 Intended Use

The DA22K control unit is a local management unit for environmental and meteorological-climatic monitoring stations capable of directly interfacing with meteorological sensors, analyzers, chemical-physical probes, actuators, etc. It has been designed to meet the most varied requirements for data acquisition, processing, and transmission, from the simplest, for single stations, to the most complex for networks of various types of stations managed by remote control centers. The chosen design criteria, and in particular the open and modular structure of the control unit, allow for significant application possibilities both in terms of ease of use and configurability, and in terms of versatility and future expandability.

Please keep this manual in a safe place and ensure that a copy is always available to operators.

1.2 Warnings

The manufacturer assumes no liability for malfunctions resulting from failure to follow the instructions, tampering, uses not covered by this manual, improper use of the device, or use by untrained operators. For normal operation and maintenance, access to the instrument is restricted to authorized and trained personnel only.

General Safety Rules

- The instrument must be connected to an electrical ground (or safety ground).
- The instrument must not be operated in the presence of flammable gases, fumes, or in any environment where there is a risk of explosion.
- Do not remove, replace, or modify any electrical or mechanical parts without authorization.
- Do not take any measurements if the instrument shows any abnormalities, such as deformation or breakage.
- Component replacement and internal work must be performed only by qualified and trained maintenance personnel, after disconnecting the main power supply.
- Pay attention to any warning labels regarding potentially hazardous procedures.

1.3 Transport

To avoid damage to the equipment, always keep it in an upright position during transport without shaking it.

1.4 Unpacking

Before removing the packaging and installing the instrument, ensure that you have taken the following precautions:

- Wear appropriate gloves to protect against abrasions, etc.
- If any damage caused during transport by the supplier is found, return the instrument to the supplier.
- Once removed from the packaging, place the instrument and its components on a flat surface.
- Always avoid turning the instrument upside down to protect the display.
- Pay attention to the connectors on the front and side of the instrument housing during the operation.

Before installing the instrument, verify that:

- The mains voltage at the installation site complies with the instrument's operating conditions.
- Ensure that the instrument's main power switch is turned off.

Do not turn on the instrument before carefully following the installation and startup instructions in this manual.

1.5 Safe Power-On Procedure

The following procedure ensures proper power supply to the DA22K control unit using an external power supply or a backup battery.

1. Connect the battery to the power connector at the BATT – GND pins (see Chapter 2).
2. Pay attention to the battery polarity: BATT must be connected to the positive terminal and GND to the negative terminal¹.
3. Connect the 12V DC external power supply to the VCC and GND pins of the power connector (see Chapter 2). This operation must be performed with the power supply turned off.
4. Pay attention to polarity: VCC must be connected to the positive terminal and GND to the negative terminal.
5. Turn on the DA22K using only the battery, with the external power supply turned off.
6. Turn on the external power supply.

1.6 During operation

During operation, avoid making any changes to the electrical connections related to the analog and digital inputs and the power supply connections.

¹ The DA22K is equipped with reverse polarity protection. However, you should still take care when making connections.

1.7 Storage

If you do not plan to use the equipment for an extended period of time (at least one year), disconnect all cables from the unit, place it in a clear plastic bag along with a packet of desiccant, and seal the bag with adhesive tape. Clearly label the bag with the contents and weight of the equipment, and include the warning "HANDLE WITH CARE."

Store the instrument in an environment with a temperature between 0 and 60 degrees and humidity not exceeding 80%. Ensure the instrument is placed in a stable position and cannot be damaged or moved due to carelessness or distraction. Do not stack other instruments or weights on top of it. Do not stack the instrument on top of other instruments, and in any case, ensure the solidity and stability of the underlying support.

1.8 Maintenance

1.8.1 Cleaning the Instrument

Before cleaning the instrument, disconnect all connection cables. Use a soft, dry cloth for cleaning. Never use damp cloths, solvents, water, or other liquids.

1.8.2 s and electrical line protection

The product is equipped with ESD protection devices on every channel and peripheral. The power supplies are also equipped with reverse polarity protection circuitry and self-resetting overcurrent protection fuses. See Chapter 2 for more details.

2 hardware and connections

2.1 Processing and storage electronics enclosure

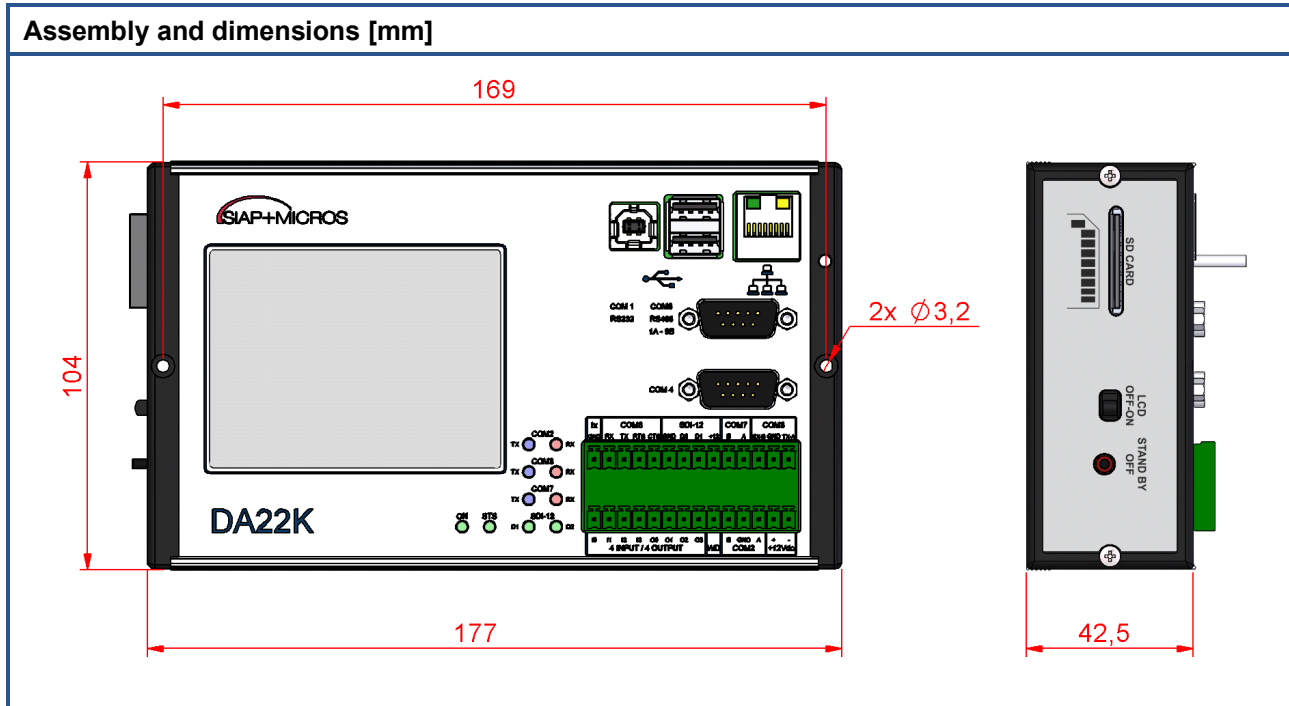

Datalogger terminal block layout

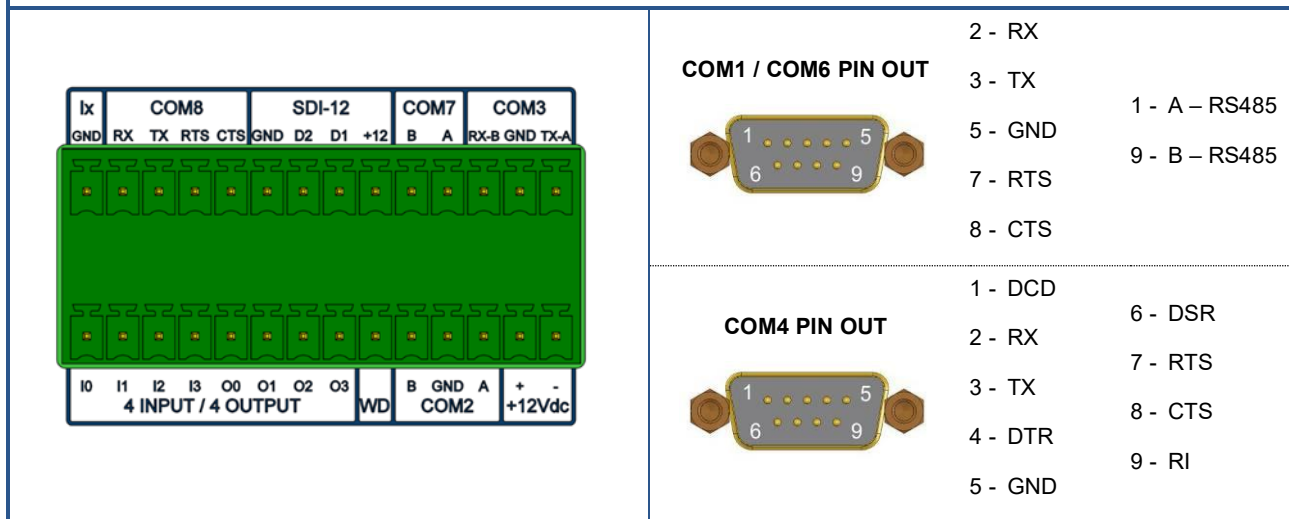

The electronics enclosure for processing and storage includes:

- A USB Type B connector for connecting via a USB cable to a PC or terminal, allowing access to the data logger's internal directories.
- A USB Type A connector for connecting peripherals such as a keyboard, mouse, or USB flash drive. Although the connector has two ports, only the upper port can be used. Do not connect peripherals to the lower port.
- A UTP connector for connecting to a local network via Ethernet protocol.

- Two 9-pin male D-sub connectors for connecting serial devices such as modems, PCs, sensors, and other equipment with RS-232 or RS-485 interfaces:
 - **COM1**: RS-232 on pins 2, 3, 5, 7, and 8 of the DSUB connector, as shown in the layout diagram.
 - **COM4**: RS-232 with all specifications.
 - **COM6**: RS-485 on pins 1 and 9 of the DSUB connector, as shown in the layout diagram.
- A 28-pin multifunction connector for connecting, respectively:
 - ² power supply (if applicable): two pins for the 12Vdc power input.
 - **COM2**: three pins for an RS-485 serial connection for connecting serial devices such as modems, PCs, sensors, and other equipment with an RS-485 interface.
 - **COM3**: three pins for an RS-485 serial interface to connect serial devices such as modems, PCs, sensors, and other equipment with an RS-485 interface. Through a mounting option, COM3 can be converted into an additional RS-232 port.
 - **SDI-12**: four pins for two independent ports for connecting peripherals using the standard SDI-12 protocol. The port consists of a 12V power supply, two data lines (D1 and D2), and ground. D1 and D2 are configured as two SDI-12 serial ports, **COM5** and **COM9**, respectively.
 - **COM7**: two pins for an RS-485 serial port for connecting serial devices such as modems, PCs, sensors, and other equipment with an RS-485 interface.
 - **COM8**: four pins for an RS-232 serial port with flow control (RTS/CTS) for connecting serial devices such as modems, PCs, sensors, and other equipment with an RS-232 interface.
 - **Watchdog**: an external watchdog signal.
 - **Digital outputs**: 4 *open-collector* digital outputs.
 - **Digital inputs**: 4 opto-isolated digital inputs.
 - **Isolated ground**: an isolated reference ground for the digital inputs.
- An SD (Secure Digital) connector for inserting an industrial-grade SD memory card used by the program to back up recorded data.
- A switch for the display backlight (forces the display backlight to turn off).
- A button for forcing the data logger out of *Suspend* mode.
- Ten LEDs representing, respectively:
 - ON, green LED indicating the power-on status.
 - STS, a flashing green LED when the data logger application is running.
 - D1, green LED indicating transmission/reception on SDI-12 COM5
 - D2, green LED indicating transmission/reception on SDI-12 COM9
 - TX, blue LED, and RX, red LED on COM2, indicating the status of the serial transmission and reception lines.

² This applies only if the power supply does not come from the base module.

- TX (blue LED) and RX (red LED) on COM3, indicating the status of the serial transmission and reception lines.
- TX (blue LED) and RX (red LED) on COM7 indicating the status of the serial transmission and reception lines.

2.2 Acquisition electronics and power management enclosure

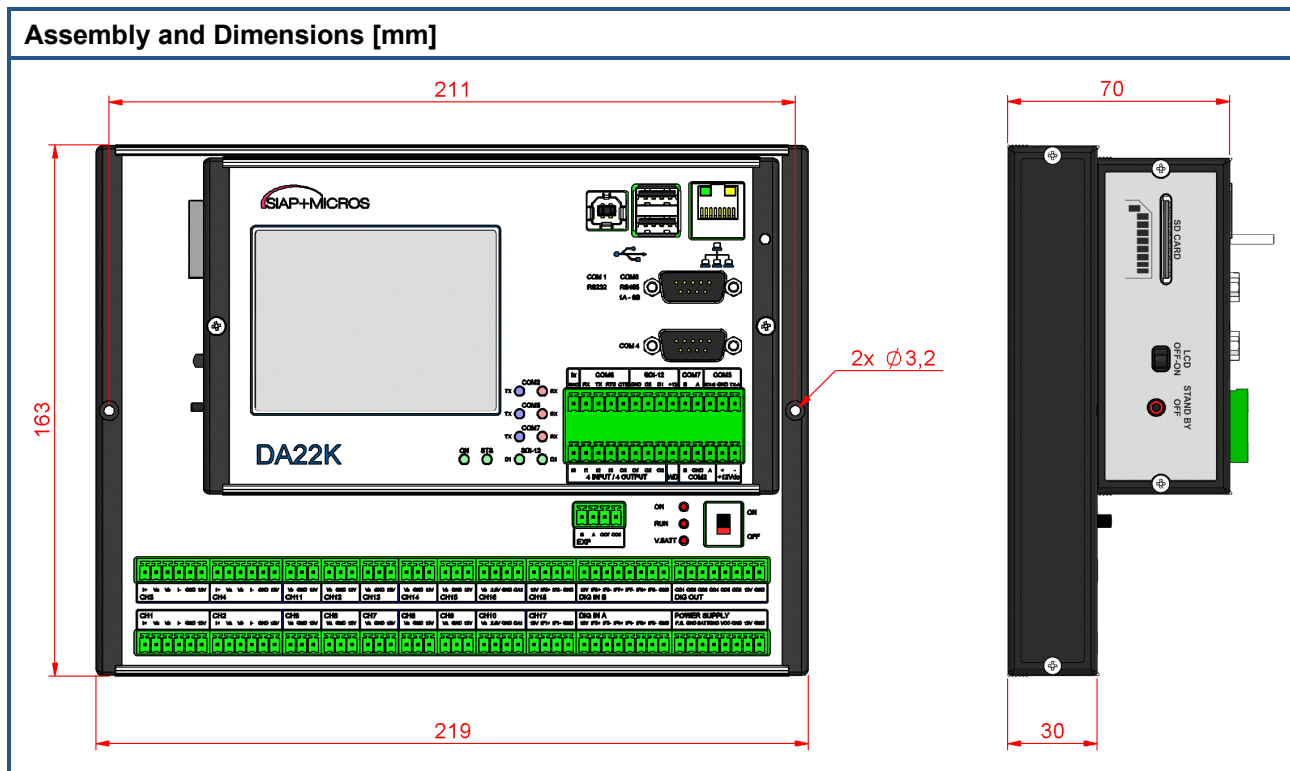

The DA22K is available in two versions that differ in the number of analog/digital inputs on the acquisition board: a basic DA22K version and an expanded DA22KE version.

This section provides a brief overview of the terminal blocks, which will be discussed in greater detail in the following sections.

Basic Terminal Block Connections

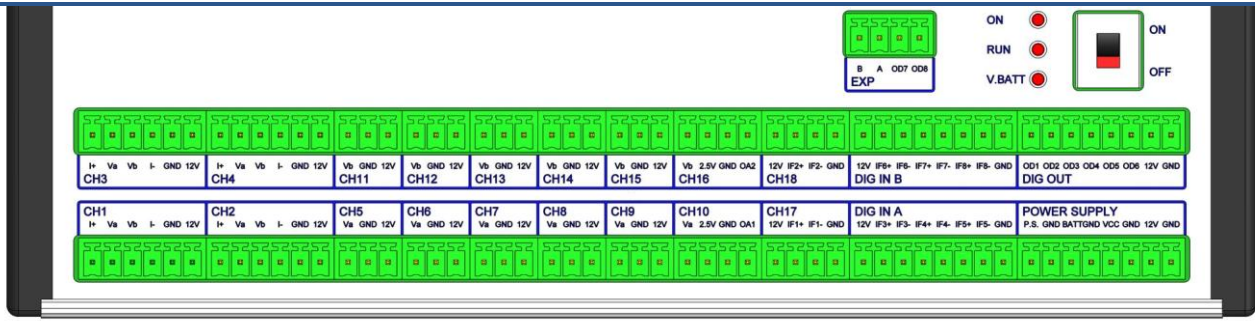

CH1–CH4: Analog inputs (24-bit) <ul style="list-style-type: none"> One differential input ($V_a - V_b$) Two ground-referenced inputs ($V_a - GND$, $V_b - GND$) One PT100 input ($I^+ - V_a - V_b - I^-$) V_{ALM} sensor power supply 	CH5–CH9, CH11–CH15: Analog inputs (24-bit) <ul style="list-style-type: none"> One differential input on each pair of connectors ($V_a - V_b$) (CH5/CH11, CH6/CH12, CH7/CH13, CH8/CH14, CH9/CH15) One ground-referenced input on a single connector ($V_a - GND$, $V_b - GND$) V_{ALM} sensor power supply
CH10, CH16: 24-bit analog inputs, 12-bit analog outputs <ul style="list-style-type: none"> One differential input on each pair of connectors ($V_a - V_b$) (CH10/CH16) One ground-referenced input on a single connector ($V_a - GND$, $V_b - GND$) Precision reference voltage 2.5V – 25mA (e.g., potentiometric wind direction sensor) 0 – 2V analog output, 12-bit 	CH17, CH18: Opto-isolated digital inputs <ul style="list-style-type: none"> Frequency Counter Logic state V_{ALM} sensor power supply
DIG IN A, DIG IN B: Opto-isolated digital inputs <ul style="list-style-type: none"> Frequency Counter Logic state V_{ALM} sensor power supply 	DIG OUT: Open-drain digital outputs and power outputs <ul style="list-style-type: none"> Open-drain digital output V_{SWT} power output at shutdown
EXP: RS-485 and open-drain digital outputs <ul style="list-style-type: none"> RS-485 Open-drain digital outputs 	POWER SUPPLY: Power Supplies <ul style="list-style-type: none"> Solar panel input (SP – GND) Battery input (BATT – GND) External power input (VCC – GND) V_{PWR} power output (12V – GND)

Additional connections on the expanded terminal block (DA22KE only)

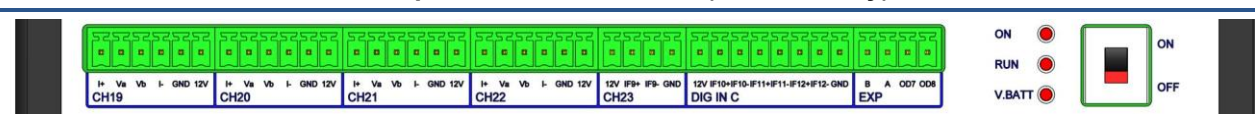

CH19 to CH22: Analog inputs (24-bit) <ul style="list-style-type: none"> One differential input ($V_a - V_b$) Two ground-referenced inputs ($V_a - GND$, $V_b - GND$) One PT100 input ($I^+ - V_a - V_b - I^-$) V_{ALM} sensor power supply 	CH23: Opto-isolated digital inputs <ul style="list-style-type: none"> Frequency Counter Logic state V_{ALM} sensor power supply
DIG IN B: Opto-isolated digital inputs <ul style="list-style-type: none"> Sinusoidal input (IF7 – IF8) 	DIG IN C: Opto-isolated digital inputs <ul style="list-style-type: none"> Frequency Counter Logic state Sinusoidal inputs (IF11 – IF12) V_{ALM} sensor power supply

In the tables above, note that:

- VALM is a fixed voltage equal to the battery voltage with a current limit of 200 mA
- VPWR is a fixed voltage equal to the battery voltage with a current limit of 2.5 A
- VSWT is a voltage that is normally present but can be turned off on command, equal to the battery voltage with a current limit of 2.5 A

In addition to the terminal blocks described above, the enclosure features an ON/OFF switch and three status LEDs with the following meanings:

- ON flashes with each measurement cycle
- RUN indicates the status of the internal watchdog
- VBATT indicates the charge status of the backup battery (1 flash indicates that the battery is low, 5 flashes indicate that the battery is fully charged).

Regarding the POWER SUPPLY connector, multiple power sources can be used; the data logger will then manage any redundancy. For example, it is possible to connect the PS solar panel simultaneously to the 12VDC external power input. The data logger will then charge the battery via the solar panel or via the 12VDC input in the absence of sunlight.

The following sections detail the electrical and measurement characteristics of the various functional sections available on the terminal block.

2.3 Power Supplies

The power supply section includes the connector labeled POWER SUPPLY and is capable of handling three possible power sources:

- Solar panel
- 12V lead-acid battery
- 12V nominal bench power supply

The solar panel input is marked with the terminals **P.S.** (positive) and **GND** (negative) and its main function is to maintain the charge on the lead-acid power battery. Solar panels for charging 12V batteries, with power up to 100W, are supported. Under sunlight, the battery charging circuit forces the panel to operate at a voltage of approximately 15.2V and is capable of delivering up to 5A to the battery. The panel input is also equipped with:

- A protection circuit against reverse polarity
- Low-pass filtering
- Electrostatic discharge (ESD) protection circuit up to 30 kV with a peak power of 160 W and compliance with IEC 61000-4-2; Level 4 (ESD); IEC 61000-4-5 (surge); IPP = 2.5 A; AEC-Q101

The battery input is marked by the **BATT** (positive) and **GND** (negative) terminals and serves to power the data logger. A 12V lead-acid battery can be connected to these terminals. The battery input is also equipped with:

- A reverse polarity protection circuit

- Protection circuit against electrostatic discharge up to 30 kV with a peak power of 160 W and compliance with IEC 61000-4-2; Level 4 (ESD); IEC 61000-4-5 (surge); IPP = 2.5 A; AEC-Q101

The bench power supply input is marked with **VCC** (positive) and **GND** (negative) terminals and, together with the battery, powers the data logger. A bench power supply with a nominal voltage of 12V and in any case less than 15V can be connected to these terminals. The input is also equipped with:

- A protection circuit against polarity reversal
- Protection circuit against electrostatic discharge up to 30 kV with a peak power of 160 W and compliance with IEC 61000-4-2; Level 4 (ESD); IEC 61000-4-5 (surge); IPP = 2.5 A; AEC-Q101

Finally, the connector features a power output that matches the battery voltage, useful for powering current-consuming devices such as radio modems and similar equipment. The output is always present and marked by the **12V** (positive) and **GND** (negative) terminals. Key features of the output include:

- 2.5 A current limit with protection via a resettable fuse
- Protection circuit against electrostatic discharge up to 30 kV with a peak power of 160 W and compliance with IEC 61000-4-2; Level 4 (ESD); IEC 61000-4-5 (surge); IPP = 2.5 A; AEC-Q101

Other output voltages, always identical in absolute value to the supply voltage, are available with different amperages on each connector.

Specifically, at the DIG OUT connector on the **12V** (positive) and **GND** (negative) terminals, there is a power supply with characteristics and amperage identical to the power supply just described, with the sole difference that this output can be turned off at will via a MODBUS command.

On all other connectors, there is an output power supply, marked as **12V**, which matches the battery voltage in absolute value and has the following characteristics:

- 200 mA current limit with protection via a resettable fuse
- Protection circuit against electrostatic discharge up to 30 kV with a peak power of 160 W and compliance with IEC 61000-4-2; Level 4 (ESD); IEC 61000-4-5 (surge); IPP = 2.5 A; AEC-Q101

These low-power power supplies are particularly useful for powering sensors that need to be acquired.

2.4 PT100 Inputs

The DA22K controller is equipped with four inputs with Pt100 acquisition functionality on connectors CH1, CH2, CH3, and CH4. In the expanded version, DA22KE, there are four additional inputs at connectors CH19, CH20, CH21, and CH22, capable of increasing the controller's acquisition capacity to a maximum of eight Pt100 thermoresistances³.

The resistance value is measured using the four-wire technique and involves the terminals **I+** (excitation current source), **Va** and **Vb** (voltage measurement across the resistance), and **I-** (excitation current return). The resistance must be connected with one end to I+ and Va and the other end to I- and Vb. Specifically, at each acquisition cycle, a pulse current (⁴) is generated at the I+ terminal; as this current flows through the thermoresistor, it creates a potential drop measured between the Va and Vb inputs. The current returns to I- and generates a reference for the radiometric measurement of the potential drop across the thermoresistor.

³ Pt100s are acquired on differential channels; therefore, each Pt100 added reduces the total number of available differential channels

⁴ Activate only during the measurement cycle to avoid altering the thermal conditions of the Pt100 due to the Joule effect

Each Pt100 input also has the following characteristics:

- Protection circuit against electrostatic discharges up to 20 kV with a peak power of 25 W and compliance with IEC 61000-4-2; Level 4 (ESD); IEC 61000-4-5 (surge); IPP = 2.5 A on both the measurement inputs and the current return for reference generation.
- Differential low-pass filtering with a cutoff frequency of 530 Hz
- Common-mode low-pass filtering with a cutoff frequency of 780 Hz
- 24-bit resolution

2.5 Analog Inputs

The controller is equipped with a number of 24-bit analog inputs, labeled Va and Vb on the connectors, which can be acquired either individually (ground-referenced) or in pairs as a differential input (Va–Vb). Specifically, the DA22K version has a total of 20 ground-referenced analog inputs that can be acquired as 10 differential inputs on connectors CH1 through CH16. The DA22KE expansion adds another 8 ground-referenced inputs that can be acquired as 4 differential inputs on connectors CH19, CH20, CH21, and CH22. All inputs have the following features:

- Electrostatic discharge (ESD) protection circuit up to 20 kV with a peak power of 25 W and compliance with IEC 61000-4-2; Level 4 (ESD); IEC 61000-4-5 (surge); IPP = 2.5 A on both the measurement inputs and the current return for reference generation.
- Differential low-pass filtering with a cutoff frequency of 530 Hz
- Common-mode low-pass filtering with a cutoff frequency of 780 Hz
- 24-bit resolution

We will now consider the three types of connectors for the 6-, 3-, and 4-pole analog inputs to better explain the connection options.

2.5.1 Analog inputs on a 6-pin connector

The connectors of this type are CH1, CH2, CH3, and CH4; the DA22KE expansion version, on the other hand, has the additional connectors CH19, CH20, CH21, and CH22. These are 6-pin multifunction connectors to which it is possible to connect, alternatively to one another,

- A Pt100-type resistance thermometer to the I+, Va, Vb, I- terminals.
- A differential voltage signal between Va (positive) and Vb (negative)
- Two ground-referenced signals Va and Vb

For electrical limits, refer to the DA22K technical specifications.

These connectors also feature a low-power 12V power supply (200 mA) as described in the preceding paragraphs, to which you should refer for details.

2.5.2 Analog inputs on 3-pin connectors

The connectors of this type are CH5, CH6, CH7, CH8, CH9, CH11, CH12, CH13, CH14, and CH15; the DA22KE expansion version has the same connectors of this type.

These connectors also feature a low-power 12V power supply (200 mA) as described in the preceding paragraphs, to which you should refer for details.

In addition to the two terminals of the aforementioned power supply, each connector has a left terminal, labeled Va or Vb, which is a ground-referenced analog input. However, it is possible to use the connectors in pairs of two to acquire differential signals. Specifically, the pairs CH5 – CH11, CH6 – CH12, CH7 – CH13, CH8 – CH14, and CH9 – CH15 can be used to connect a differential signal. In this case, Va indicates the positive terminal of the signal and Vb the negative terminal.

2.5.3 Analog Inputs on 4-Pin Connectors

The connectors of this type are CH10 and CH16 and are entirely analogous to the 3-pin connectors in terms of the functionality of the Va and Vb inputs and their mode of use. A distinctive feature of this type of connector is the presence of:

- **Reference voltage**
 On both connectors, the **2.5V** terminal provides a 2.5V reference useful for measuring, for example, signals from a potentiometer such as wind direction.
- **Analog output**
 On CH10, terminal **OA1** denotes a 12-bit 0–2.5V analog output configurable via MODBUS command. On CH16, the analog terminal is denoted by **OA2**.

2.5.4 Analog Inputs Configurable for 4–20 mA

The DA22K data logger, like the DA22KE, has four of the described analog inputs that can be configured to acquire 4–20 mA current signals without the need for external precision resistors. These 100Ω resistors are, in fact, already included in the DA22K, allowing the conversion of 4–20 mA current signals into 0.4–2 V voltage signals. The channels configured for this functionality are CH8, CH9, CH14, and CH15. To enable the resistor, the user must unscrew the processing electronics housing from the one below it (see the figure below). This will provide access to four switches, each of which enables the resistor on the corresponding acquisition channel.

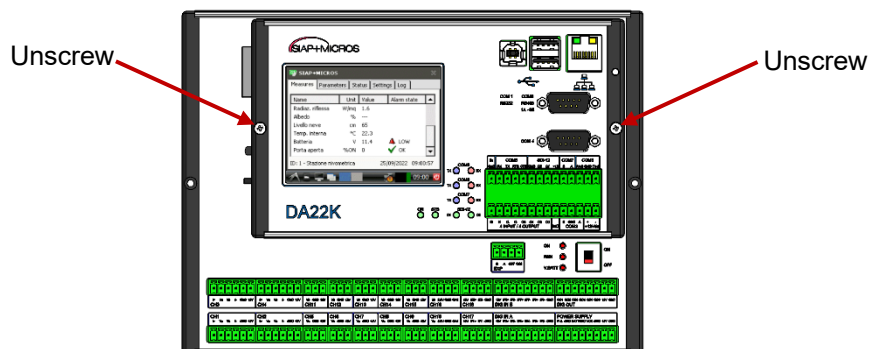

2.6 Digital Inputs

The control unit's acquisition board is equipped with eight digital inputs on connectors CH17, CH18, DIG IN A, and DIG IN B. The inputs are intended to be used in pairs; therefore, the pair (IF1+ ÷ IF1-) on CH17 constitutes one input, and so on for all the others.

Key features of these inputs are:

- Pair of opto-isolated inputs with an isolation voltage of 5 kV_{RMS}
- Internal limiting resistance of 10 kΩ
- Automatically acquired at one-second intervals as
 - Frequency
 - Count
 - Logic state

The schematic diagram of the input is shown in the following figure.

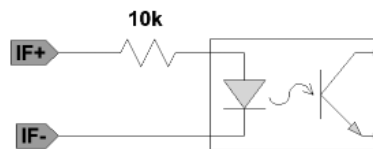

This input type allows for the acquisition of both square-wave signals—by connecting IF- to ground and IF+ to the signal's positive terminal—and dry contacts. In the latter case, a supply voltage must be applied to IF+ to bias the phototransistor, and the dry contact must be connected to IF-. For this purpose, a 12V supply is provided at the connectors. For example, a dry contact connected to CH17 must be wired with a jumper between the **12V** terminal and the **IF1+** terminal; the dry contact can then be connected between **IF-** and **GND**. When the contact is open, no current flows through the photodiode, and the signal transmitted to the data logger is read as a high logic state due to the internal pull-ups. When the contact closes to ground, current flows through the photodiode, and the signal transmitted to the data logger is read as a low logic state.

In the case of data loggers with the DA22KE expansion, there are still eight opto-isolated digital inputs like the previous ones, plus four comparator inputs for AC and⁵ sensors (such as variable reluctance sensors); however, these inputs are positioned differently on the relevant connectors. Specifically, the channels are divided among the connectors as follows:

- CH17
 - IF1 opto-isolated digital input
- CH18:
 - IF2 opto-isolated digital input
- DIG IN A:
 - IF3, IF4, and IF5 optically isolated digital inputs
- DIG IN B
 - IF6 optically isolated digital input
 - IF7, IF8 differential comparator inputs
- CH19:

⁵ For example, variable reluctance sensors such as certain wind speed sensors

- IF9 optically isolated digital input
- DIG IN C:
 - IF10 optically isolated digital input
 - IF11, IF12 differential comparator inputs

We have already discussed the opto-isolated inputs, while the other type of input features a differential comparator that, given a sinusoidal input waveform, produces a square wave of the same frequency that is used for data acquisition. This feature allows for the use of passive sensors, such as certain wind speed sensors with a sinusoidal output. As with the optically isolated inputs, these inputs can also be read as frequency, count, or logic state and are equipped with an ESD protection circuit rated up to 23 kV with a peak power of 500 W, compliant with IEC 61000-4-2 Level 4 (ESD), IEC 61000-4-5 (surge) $I_{pp} = 18$ A.

In addition to all these inputs, there are four more inputs on the 28-pin connector of the control unit's processing and control section. These inputs are also optically isolated with an isolation voltage of 3.75 kV but can only be read as status inputs.

In summary, the DA22K offers 8 opto-isolated mixed-type digital inputs (frequency, count, status) and 4 opto-isolated status digital inputs. The expansion adds another 4 mixed-type digital inputs (frequency, count, status) for sinusoidal inputs to these inputs.

2.7 Digital Outputs

The controller's acquisition base is equipped with eight open-drain digital outputs, six on the DIG OUT connector and two on the EXP connector. Each digital output has the following characteristics:

- Open-drain type with a limiting resistor of $1\Omega - 0.25W$
- Maximum current 500mA
- Electrostatic discharge protection circuit up to 25 kV with a peak power of 350 W and compliance with IEC 61000-4-2 (ESD) 15 kV (air) 8 kV (contact), IEC 61000-4-4 (EFT) 40 A (5/50 ns), IEC 61000-4-5 (lightning) 23 A (8/20 μ s).

The 28-pin connector on the processing and control unit features four additional digital outputs, O0, O1, O2, O3, with the following characteristics:

- Open-collector type
- Maximum current 100 mA
- Electrostatic discharge protection circuit up to 30 kV with a peak power of 200 W and compliance with IEC 61000-4-2 (ESD) 30 kV (air) 30 kV (contact), IEC 61000-4-4 (EFT)

2.8 Connectivity

The DA22K features a wide range of communication interfaces, including RS-232, RS-485, Ethernet, USB, etc. The following sections will analyze the characteristics of the various communication interfaces available.

2.8.1 RS-232 serial interfaces with the following specifications: COM1, COM4, COM8

The control unit is equipped with three RS-232 serial interfaces with additional signals, meaning that, in addition to transmission and reception, the interface connector also carries other control signals. These are:

- **COM1:** 9-pin DSUB connector carrying pins 2, 3, 5, 7, and 8 of the connector, i.e., the signals: RX, TX, GND, RTS, CTS.
- **COM4:** 9-pin DSUB connector carrying all the signals of the connector, namely: DCD, RX, TX, DTR, GND, DSR, RTS, CTS, RI.
- **COM8:** Part of the 28-pin connector, it carries the signals RX, TX, RTS, and CTS.

Communication devices such as cellular modems, radio interfaces, etc., can be connected to these ports. They can also be used for direct connection to a configuration terminal such as a personal computer. In the latter case, the data logger and the computer must be connected via a NULL MODEM cable, i.e., with both ends being 9-pin female D-sub connectors and with pins two and three reversed so that the computer's transmission reaches the data logger's reception and vice versa.

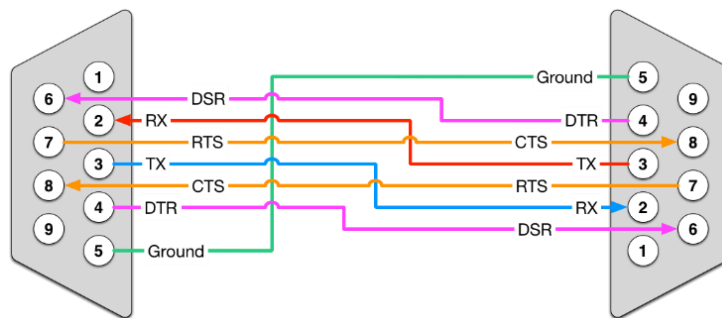

Regarding protection, each RS-232 serial port is equipped with a 15 kV electrostatic discharge protection circuit (IEC 61000-4-2 Air Gap and Human Body Model).

2.8.2 RS-485 serial interfaces: COM2, COM6, COM7

The data logger has three serial communication interfaces dedicated entirely to connecting RS-485 devices:

- **COM2**
 It is part of the 28-pin connector and carries signals A, B, and ground. B has a 4.7kΩ pull-down to ground, while A has a 4.7kΩ pull-up to the internal power supply. This interface is also internally connected to the lower acquisition base of the EXP connector, terminals **B** and **A**, and is used by the processing and storage unit to retrieve data acquired by the acquisition base.
- **COM6**
 It is part of a 9-pin D-Sub connector, the same as COM1, where pin 1 is A and pin 9 is B. B has a 4.7 kΩ pull-down to ground, while A has a 4.7 kΩ pull-up to the internal power supply.
- **COM7**
 It is part of the 28-pin connector and carries signals A and B. B has a 4.7kΩ pull-down to ground, while A has a 4.7kΩ pull-up to the internal power supply.

The interfaces can be used for sensor acquisition or to communicate with devices featuring an RS-485 interface. The interfaces are equipped with protection circuits against electrostatic discharge. Specifically:

- The 28-pin connector and the D-Sub connector feature ESD protection circuits up to 30 kV, compliant with the following standards: IEC 61000-4-2 ±30 kV contact discharge, ±30 kV air discharge, and AEC-Q101: human body model class H3B > 8 kV.

- The EXP connector features an electrostatic discharge protection circuit up to 30 kV, compliant with IEC 61000-4-2 (ESD) 30 kV (air) 30 kV (contact), IEC 61000-4-4 (EFT) 50 A (5/50 ns), IEC 61000-4-5 (lightning) 19 A (8/20 μ s).

2.8.3 RS-232 and RS-485 hybrid serial interfaces: COM3

The DA22K is equipped with a hybrid serial port, COM3, which can be either RS-485 or RS-232; the choice must be specified at the time of ordering since, normally, this port is configured as RS-485 while the RS-232 configuration is optional. The corresponding terminals on the 28-pin connector of the processing and testing unit are:

- **RX – B:** B (negative) of RS-485 or RS-232 receive if requested.
- **GND:** ground
- **TX – A:** A (positive) of the RS-485 or transmission of the RS-232 if requested.

Any pull-up or pull-down resistors must be added externally.

When used as an RS-485 interface, it is equipped with an electrostatic discharge protection circuit rated up to 30 kV, in accordance with the following standards: IEC 61000-4-2 \pm 30 kV contact discharge, \pm 30 kV air discharge, and AEC-Q101: Human Body Model Class H3B > 8 kV.

When used as RS-232, it is equipped with a 15 kV electrostatic discharge protection circuit (IEC 61000-4-2 Air Gap and Human Body Model).

2.8.4 SDI-12 Interfaces: COM5, COM9

The 28-pin connector features two communication interfaces for sensor acquisition in accordance with the SDI-12 communication standard. The interfaces consist of the following terminals:

- **+12:** 12V nominal sensor power supply with a 100 mA limit according to the standard
- **D1:** COM5 data line at 5V.
- **D2:** COM9 data line at 5V.
- **GND:** power supply ground.

The 5V data line, as required by the standard, is left in high impedance via a tri-state buffer when not in use. This line also features an electrostatic discharge protection circuit up to 30 kV, compliant with reference standards IEC 61000-4-2 \pm 30 kV contact discharge, \pm 30 kV air discharge, and AEC-Q101: human body model class H3B > 8 kV.

2.8.5 Network Interface

There is an Ethernet connector to which a 10/100 Mbps Base-T network card is connected, managed at the low-level by the operating system. The electrostatic discharge immunity characteristics for this interface are:

- \pm 4 kV Human Body Model according to ANSI/ESDA/JEDEC JS-001
- \pm 1 kV Charged Device Model according to JEDEC JESD22-C101 specifications

2.8.6 USB Host Interfaces

There is a female USB Host Type-A interface to which devices such as USB flash drives, keyboards, mice, etc., can be connected.

The interface is equipped with a dedicated transient voltage suppression circuit tailored to USB signal characteristics. The circuit is also protected against electrostatic discharge up to 15 kV in accordance with IEC 61000-4-2 standards, specifically

- ± 15 kV Human Body Model
- ± 2 kV Machine Model

2.8.7 USB Slave Interfaces

A female USB Type B slave interface is provided for connecting to and accessing the data logger's file system. The interface is equipped with a dedicated transient voltage suppression circuit specifically designed for USB signal characteristics. The circuit is also protected against electrostatic discharge up to 15 kV in accordance with IEC 61000-4-2 standards, specifically

- ± 15 kV Human Body Model
- ± 2 kV Machine Model

2.9 External storage devices and display

During normal operation, the collected data is stored in a database located in the device's internal memory (non-volatile flash memory). However, it is also possible to copy the data to a removable external storage medium (data backup).

On the left side of the data logger is a connector that can accommodate an SD card storage device; this is automatically managed by the operating system, which recognizes it as an external disk drive (⁶). It is also possible to insert a USB flash drive into the USB host connector and use it as a data storage device ⁶.

For visualization, there is a 3.5" TFT-LCD touchscreen display with a resolution of 320 x 240 and 16 million colors. The display is transmissive with white backlighting⁷.

The display provides a graphical interface to the Linux operating system and allows the user to interact with the management program. Further details are provided in the following chapters.

⁶ The larger the storage capacity of the peripheral device (SD Card or USB Flash), the longer the initial recognition will take.

⁷ If not driven, it is normally white.

3 User Guide and Configuration

This chapter provides a comprehensive overview of the configuration and use of the **DA22K** control unit. In particular, it describes the operating system architecture and the features of the integrated management software (application firmware).

The application implements the main functions of a data logger, including data acquisition from measurement sensors, data processing and recording, as well as data transmission via available communication devices.

3.1 Operating System

The **DA22K** data logger is a device based on an **embedded Linux** system, built using **the Yocto Project**, Poky distribution version 4.0.8 LTS (Kirkstone), and Linux kernel 5.15.105.



The operating system is preloaded on the following internal storage:

- **SD Card**
Removable industrial-grade SD card (capacity: 1GB or 2GB)

The data logger application and data archives, on the other hand, reside on the following drive:

- **NAND Flash**
Internal non-volatile NAND Flash memory (capacity: 256MB)

The application management files are located in the default folder: **/mnt/nandflash/da20k**

List of files and folders:

- **arc** Data archive folder (.db)
- **log** Log file folder (.log)
- **ftp** Temporary folder for FTP transfer.
- **ini.xml** Data logger initialization file.
- **cnf.xml** Data logger configuration file.
- **da20k** Datalogger management application (firmware).
- **start.sh** Application startup shell script.
- **backlight.sh** Shell script for managing the display backlight.
- **openvpn.sh** VPN client connection shell script (optional).
- **config.ovpn** Configuration file for the VPN client (optional).

3.1.1 Startup

The data logger management application (**da20k** firmware) starts automatically after the operating system has finished loading, via a link to the **start.sh** shell script.

Upon first startup, the system automatically creates the subfolders necessary for proper operation. Any additional processes required by the data logger are also automatically started during the boot phase.



Booting Embedded Linux

Upon power-on, wait approximately 1 minute for the operating system to finish booting and the application to load. At the end of this phase, the display will show the initial screen.



Initial graphical screen

For instructions on using the graphical interface, refer to section [3.2 – Display Interface](#).

3.1.2 Remote connection

You can connect to the system via the **LAN** network card using **SSH (Secure Shell)** access by connecting to the following host: [da22k@192.168.1.5](ssh://da22k@192.168.1.5)

Terminal command:

```
ssh da22k@192.168.1.5
```

For more advanced control over system settings, it is recommended to use software that supports remote connections via **SSH** or **SFTP**, providing a graphical interface for browsing and managing files.

One example is **WinSCP**, a graphical SFTP client for Microsoft Windows systems, which allows you to browse the remote device's file system and securely transfer files using the SSH protocol.

To connect to the DA22K data logger:

1. Open WinSCP.
2. Create the remote site to connect to by entering the following information:
 - **Protocol:** SFTP
 - **Server:** 192.168.1.5
 - **Port:** 22
 - **Username:** da22k
 - **Password:** *****
3. Click "**Log In**" to connect and browse the device's contents.

Example of viewing the application folder with WinSCP:

/mnt/nandflash/da20k/				
Nome	Dimensione	Modificato	Diritti	Proprietario
		23/09/2024 15:19:49	rw-r--r--	root
arc		25/09/2024 13:19:00	rw-r--r--	root
log		25/09/2024 02:00:05	rw-r--r--	root
ftp		23/09/2024 15:31:13	rw-r--r--	root
 cnf.xml	9 KB	23/09/2024 15:56:54	rw-r--r--	root
 ini.xml	1 KB	23/09/2024 10:00:00	rw-r--r--	root
da20k	1 474 KB	20/09/2024 18:32:17	rw-r--r--	root
start.sh	2 KB	26/06/2024 11:00:00	rw-r--r--	root
openvpn.sh	1 KB	08/11/2023 08:00:00	rw-r--r--	root
resolv.conf.head	1 KB	04/08/2023 10:00:00	rw-r--r--	root

Note: The device's SSH server is configured to listen exclusively on the local address. Any changes to the SSH service settings can be made by editing the configuration file located at the following path: `/etc/ssh/sshd_config`

3.1.3 Network Configuration

The network interface (**eth0**) configuration is defined in the Linux network interfaces file, located at: `/etc/network/interfaces`

By default, the **eth0** interface is configured with a default **static IP** address of: **192.168.1.5**

`/etc/network/interfaces`

```
# Configurazione delle interfacce di rete

# Abilita l'interfaccia eth0 all'avvio
auto eth0

# Configurazione dell'interfaccia eth0 con un indirizzo IP statico
iface eth0 inet static
    address 192.168.1.5      # Indirizzo IP del dispositivo
    netmask 255.255.255.0   # Maschera di rete
    network 192.168.1.0     # Indirizzo di rete
    gateway 192.168.1.1     # Gateway predefinito
    dns-nameservers 8.8.8.8 8.8.4.4 # Server DNS
```

Network configuration details:

- **auto eth0**: indicates that the eth0 interface will be enabled automatically at system boot.
- **iface eth0 inet static**: specifies that the eth0 interface uses a static IPv4 address.
- **address 192.168.1.5**: sets the device's IP address to 192.168.1.5.
- **netmask 255.255.255.0**: defines the subnet mask, which determines which IP addresses belong to the same network.
- **network 192.168.1.0**: specifies the network address, which represents the local network.
- **gateway 192.168.1.1**: sets the default gateway (used to route traffic to external networks).
- **dns-nameservers 8.8.8.8 8.8.4.4**: specifies the DNS servers to use for name resolution. In this case, Google's public DNS servers are used.

If you want the IP address to be assigned dynamically via **DHCP**, use the following configuration:

```
# Configurazione delle interfacce di rete

# Abilita l'interfaccia eth0 all'avvio
auto eth0

# Configura eth0 per utilizzare DHCP
iface eth0 inet dhcp
```

Note: You can also easily configure the network adapter using the graphical user interface. For this, refer to section [3.2.16 – Network](#).

3.1.4 Modem Configuration

Modem configuration allows you to establish an Internet connection using a **3G/4G** mobile network modem.

The modem (both internal and external) is normally connected to the datalogger's **COM4** port. The default settings for the serial port are as follows:

- **Baud Rate:** 38400 bps
- **Data Bits:** 8
- **Parity:** None
- **Stop Bits:** 1

To establish an Internet connection, the system uses the **PPP (Point-to-Point Protocol)** to create a virtual network interface named **ppp0**.

The PPP connection configuration files are described below.

PPP Configuration (Internet)

PPP uses the configuration file located at: `/etc/ppp/peers/internet`

```

# /etc/ppp/peers/internet

# Parametri generali
debug          # Abilita il debug per log dettagliati
local         # Non utilizza DCD (Data Carrier Detect)

# Parametri modem
/dev/ttySC0   # Seriale COM4 (dove il modem è collegato)
38400        # Velocità seriale (baud rate)

# Parametri di connessione PPP
noauth        # Non richiedere autenticazione locale
defaultroute  # Imposta la rotta predefinita
usepeerdns    # Usa il DNS del provider
connect "/usr/sbin/chat -v -f /etc/chatscripts/dialup -T *99***1#"
  
```

CHAT connection script

Connection script (CHAT)

The PPP configuration calls a **CHAT** script to initiate the connection with the modem. The phone number for anonymous connection is passed via the **-T *99***1#** parameter

The script file is located at: /etc/chatscripts/dialup

```
# /etc/chatscripts/dialup

#ECHO          ON
ABORT          "BUSY"
ABORT          "NO CARRIER"
ABORT          "NO ANSWER"
ABORT          "ERROR"
ABORT          "+CGATT: 0"
TIMEOUT        12
""            ATV1
OK             ATE0
OK             ATH
OK             \d\dATD\T
TIMEOUT        22
CONNECT        ""
```

PPP Connection Test

To manually activate the PPP connection, run the following command:

```
$ pon internet
```

You can verify that the PPP interface has been activated with the command:

```
$ ifconfig ppp0
```

If the connection is active, a **ppp0** network interface with an assigned IP address will be displayed:

```
ppp0: flags=4305<UP,POINTOPOINT,RUNNING,NOARP,MULTICAST> mtu 1500
inet 10.13.17.172 netmask 255.255.255.255 destination 10.64.64.64
ppp txqueuelen 3 (Point-to-Point Protocol)
RX packets 161 bytes 12224 (11.9 KiB)
RX errors 0 dropped 0 overruns 0 frame 0
TX packets 176 bytes 9876 (9.6 KiB)
TX errors 0 dropped 0 overruns 0 carrier 0 collisions 0
```

3.1.5 VPN Client

The DA22K data logger supports the automatic startup of an **OpenVPN client** connection.

During system startup, the dedicated script checks for the presence of the configuration file:

config.ovpn

If the file is present and valid, the script will automatically start the OpenVPN client, establishing a VPN connection to the configured remote server.

If the file is missing, the OpenVPN service will not start.

This method allows you to enable or disable the VPN tunnel simply by adding or removing the configuration file, without the need to modify the operating system or startup scripts.

Creating the configuration file requires entering specific parameters for the VPN server. To obtain the correct, customized file, you can contact the SIAP+MICROS support service, which will provide the necessary assistance for generating and configuring the VPN.

Contents of the *config.ovpn* file

The *config.ovpn* file defines all the parameters necessary for a secure connection to the VPN server. Specifically, it must contain:

- Parameters and operating mode
- Remote VPN server
- Security and encryption
- Connection management
- Password authentication
- Certificates and keys ^(*) :
 - CA Certificate
 - Client certificate
 - Client private key (encrypted)

^(*) Including certificates directly within a single file makes the configuration self-contained, simplifying service management.

In the event of configuration or authentication errors, the VPN tunnel will not be established, and the event will be logged in the system logs

3.1.6 FTP Server

The DA22K data logger comes pre-installed with the **vsftpd (Very Secure FTP Daemon)** FTP server service.

The service allows remote access to the device for file read and write operations and is typically used to retrieve images generated by a webcam connected locally on the LAN.

Default credentials and directories

FTP User: webcam
Password: w3bc4m
Access directory: /mnt/nandflash/da20k/image

The "webcam" user has access exclusively to the specified folder, which is used as the main directory for image transfer.

The FTP service is available on the system but does not start automatically at boot. To ensure it persists after a reboot, you must enable automatic startup in the operating system's run levels.

Enabling automatic startup

Enabling the FTP service at system startup is done using the command:

```
update-rc.d vsftpd defaults 50 20
```

Starting the service

The service can be started immediately without waiting for the system to reboot using the command:

```
service vsftpd start
```

Stopping the service

The service can be temporarily stopped with the command:

```
service vsftpd stop
```

Checking the status

To verify that it is properly enabled and running:

```
service vsftpd status
```

Notes

The permanent enablement of the FTP service must be carefully evaluated, particularly on systems connected to public or mobile networks. It is recommended to enable it only when necessary.

Any changes to users, permissions, or access directories must be requested from SIAP+MICROS support, which will provide the necessary assistance.

3.1.7 Clock Setup

To ensure an accurate time reference, the data logger is equipped with an integrated on-board **RTC** hardware clock. The **RTC (Real-Time Clock)** device is used to periodically synchronize the operating system's internal clock.

Upon first power-up, both the system clock and the RTC clock may not be set correctly. You can set them via a connection to the system as follows:

Setting the system clock

For example, suppose you want to set the date to September 23, 2024, at 12:30 p.m. Use the 'date' command as follows:

```
$ date -s "2024-09-23 12:30:00"
```

Synchronizing the hardware clock (RTC)

After setting the system clock, you must also synchronize the hardware clock (RTC) with the following command:

```
$ hwclock --systohc
```

Note: The above setup and synchronization procedure can be simplified by using the display interface (see section **3.2.15 – Date & Time**) or by using the **DAK** application software as described below:

Clock setup and synchronization via the DAK application

- 1) Select: *Run – Synchronize Clock*
- 2) Set the date.
- 3) Set the time (or select: *Synchronize with PC clock*).
- 4) Press *Send* and confirm the operation.

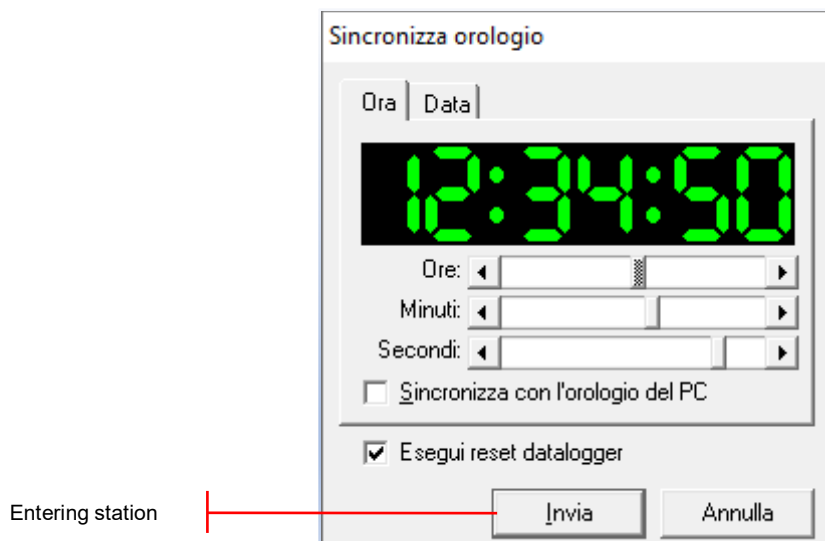

3.2 Display interface

The DA22K data logger is equipped with a **touchscreen** display that allows the user to view the acquired data and configure the system. Various graphical pages are available that display, depending on the loaded configuration, the acquired measurements and the status of the control unit.

Interaction is via touch on the screen:

- press the icon button to select the corresponding page;
- swipe your finger to scroll through a list or table in the desired direction;

The display backlight is normally off to reduce power consumption; the display can be reactivated by touching the screen or by pressing the side button (STAND-BY OFF).

After 10 minutes of inactivity, the display turns off automatically. Alternatively, you can turn off the display immediately by tapping the "**Display Off**" icon 

3.2.1 Home Screen

The home screen displays the **Login** button,  which the user can use to log in to the data logger:



DA22K Display – Home Screen

3.2.2 User Login

If the data logger has been previously configured for user management, the subsequent login screen will prompt you to enter your login credentials (username and password). Otherwise, access will be anonymous, and the display will proceed directly to the main screen.

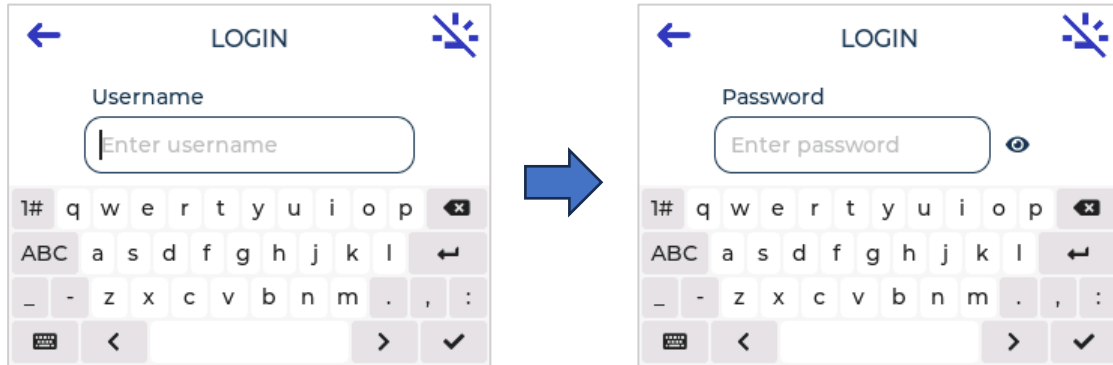

Login Screens – Username and Password Request

Logging in with a specific user account allows for the differentiation of roles and permissions based on the following levels:

- **Level 0:** standard user authorized only to view data (measurements and station status);
- **Level 1:** Owner user authorized to configure and update the station;
- **Level 2:** Administrator user with full permissions (system service and configuration)

Once logged in and the main page (**Home page**) has opened, the user can continue browsing.

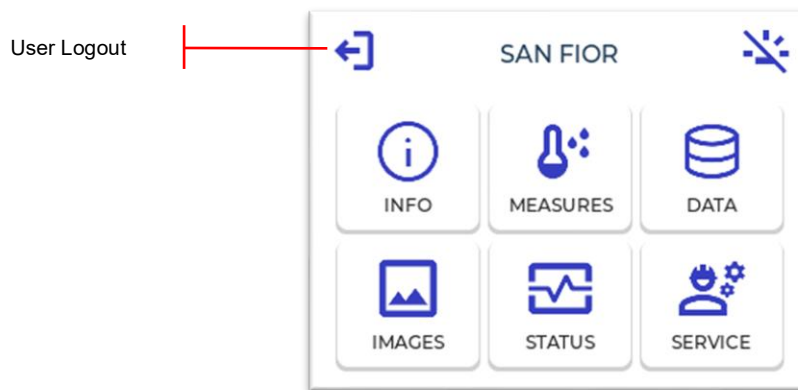



Main screen (Home page)

From the main screen, you can access:

1. INFO – Station information
2. MEASURES – Current measurement values
3. DATA – Recorded data values
4. IMAGES – Images captured by the webcam (if available)
5. STATUS – Datalogger status
6. SERVICE – Service operations

To return to the home page, use the following buttons/icons:

-  *Back* Return to the previous page
-  *Home* Return to the main page

If you are inactive for more than 60 minutes, your current session will be automatically closed and you will need to log in again. To manually end your session, click the **Logout** icon on the main screen



3.2.3 Station Information

The **INFO** page allows you to view the station's profile information.

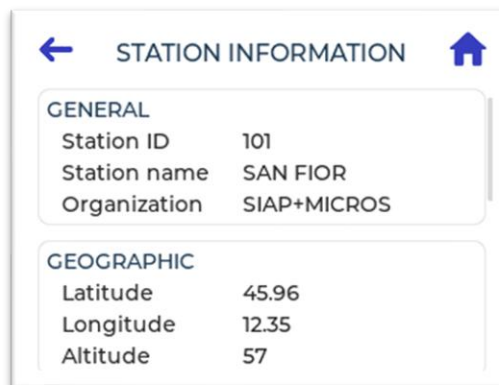

Station Information Screen

In detail:

General Information

- Station ID;
- Station name;
- Organization;

Geographic coordinates

- Latitude;
- Longitude;
- Elevation;

Date and time

- Local time zone;
- NTP (Network Time Protocol) time synchronization server;
- Internal clock (RTC) update interval;

Communication settings

- Device ID (Modbus);
- Listening TCP/IP port and communication protocol;
- COM1...COM4 serial ports enabled for communication and communication protocol;
- TUNNEL server address and communication protocol;

3.2.4 Current Measurements

The **MEASURES** page displays a real-time list of measurement sensors and their respective acquired values. Only the elements configured in the display section are included in the list.

To scroll through the measurements, drag the list in the desired direction.

The page normally refreshes every 3 seconds.

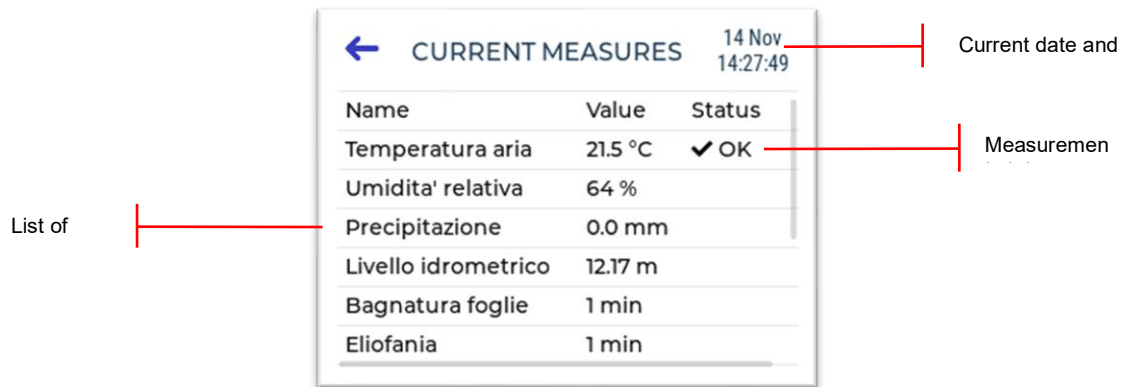

Current measurements screen

Details of displayed fields:

- Measurement name;
- Value and engineering unit;
- Measurement status;

The measurement status is displayed only if the acquired sensor has an associated alarm control; otherwise, it will not be displayed. Possible status values are:

- | | |
|----------------------|--|
| ✓ OK | Normal measurement (within threshold limits) |
| ⚠ HIGH / LOW WARNING | Pre-alarm measurement (high or low warning threshold exceeded) |
| 🔔 HIGH / LOW ALARM | Alarm reading (high or low alarm threshold exceeded) |
| ✘ ERROR / OVER RANGE | Acquisition error or out-of-range measurement |
| ⏸ PAUSE | Sensor under maintenance (recording paused) |

To return to the previous page, tap the *Back* icon
 or to return to the main page, tap the *Home* icon



3.2.5 DAT s and history

The **DATA** page displays a tabular report of the latest data recorded in the archive (latest historical record).

To scroll through the displayed data, drag the table in the desired direction.

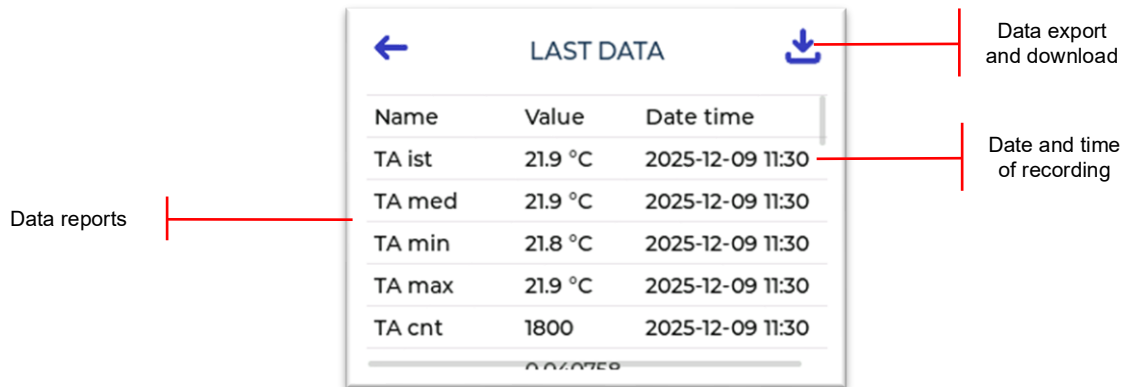

Historical data screen



The page refreshes at intervals equal to the minimum recording interval.

The fields displayed in detail:

- Data name;
- Value and engineering unit;
- Date and time of recording;

From this page, the user can export and save the data to an external storage device (SD card or USB drive). The generated file can contain up to 31 days of data.

Data export and download procedure

1. Insert the external storage device (SD card or USB drive).
2. Click the  download icon. A dialog box will open for selecting the export.
3. Select the start and end dates of the period (the maximum allowed period is 31 days).
4. Select the desired format from the available options (for example: *CSV report - wide table*).
5. Start the export by pressing OK 

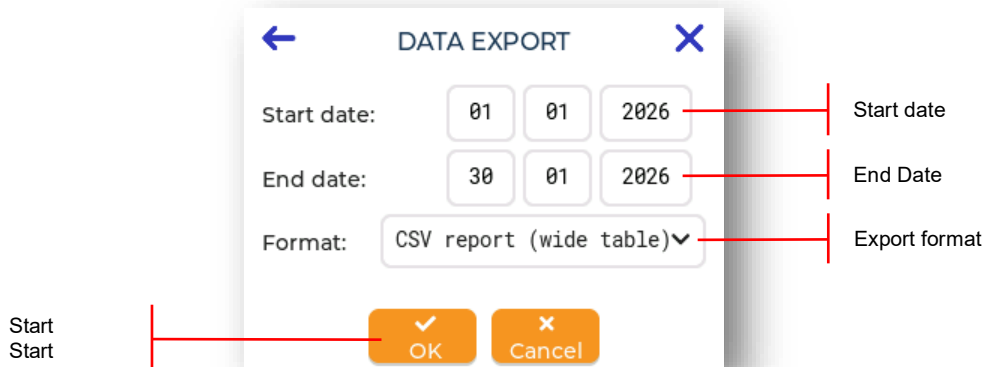

Data export

6. Once the export is complete, a window will open to select the location where the file will be saved.
7. Select the destination folder and confirm the data download by clicking YES. The following message will confirm the success of the operation:

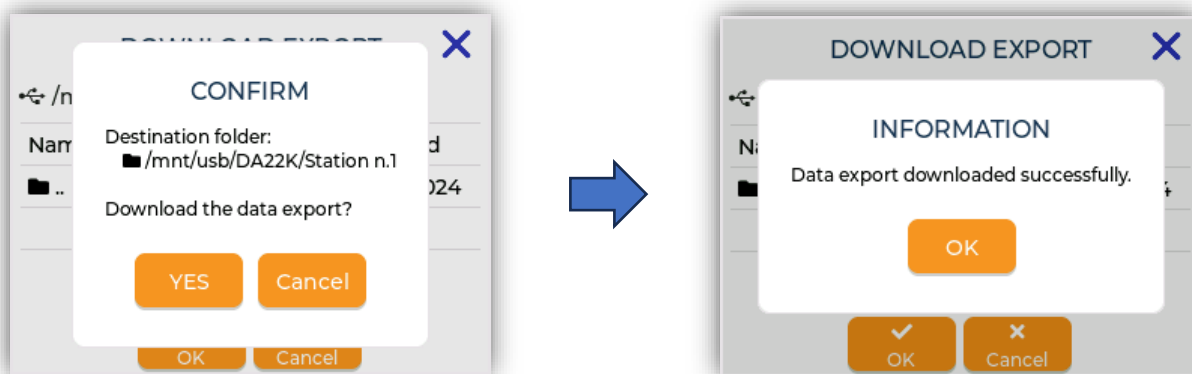

Export download

3.2.6 Datalogger Status

The **STATUS** page provides access to two information screens:

1. CONNECTIONS STATUS – Status of the data logger’s connections.
2. STORAGES STATUS – Status of the data archives.

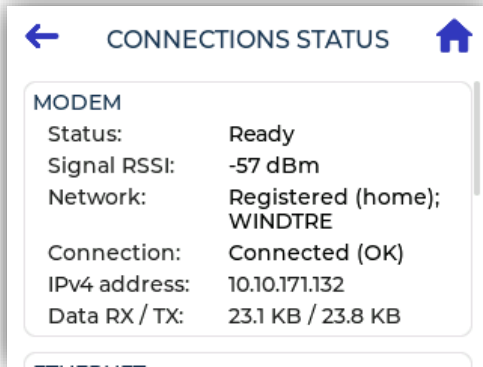

Connection Status

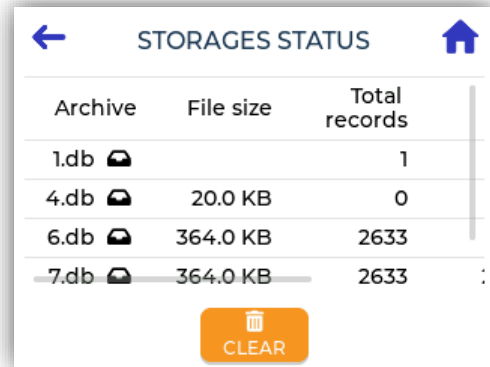

Archive Status

The CONNECTIONS STATUS screen displays the statuses of the data logger’s communication channels. Specifically:

MODEM

- Communication status (Ready, Disabled, Error);
- Received signal strength (RSSI);
- Network and mobile operator registration status;
- PPP (Point-to-Point) connection status;
- Assigned IPv4 address;
- Data received and transmitted (KB);

ETHERNET

- Interface name (eth0);
- Status (UP/DOWN, RUNNING/NOT RUNNING);
- IP address;
- Netmask;
- MAC address;
- Data received and transmitted (MB);

INTERNET

- Connection status (Online, Offline);

TUNNEL

- Communication status (Connected, Disconnected);

To view all available information, scroll vertically down the page.

The STORAGES STATUS screen displays a list of the log databases currently configured and in use in the data logger. The list allows you to check the size, number of records, and transfer progress.

The following information is displayed for each archive:

- Archive file name (.db);
- Current file size;
- Total number of stored records;
- Number of records still to be read or transferred;

Scroll through the list both vertically and horizontally to view all available fields.

Archive cleanup procedures

1. CLEAR ARCHIVE

If you need to delete data from a single archive, click the *Trash* icon at the end of the  row. If you are sure you want to proceed, confirm by clicking YES:

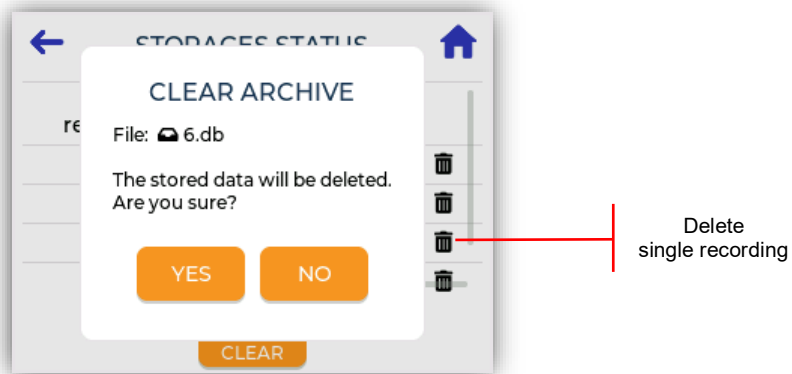

2. CLEAR ALL

To delete all existing records and start from scratch (complete reset), press the central CLEAR button  and confirm with YES when the warning message appears.
 Warning! All recorded data will be permanently deleted:

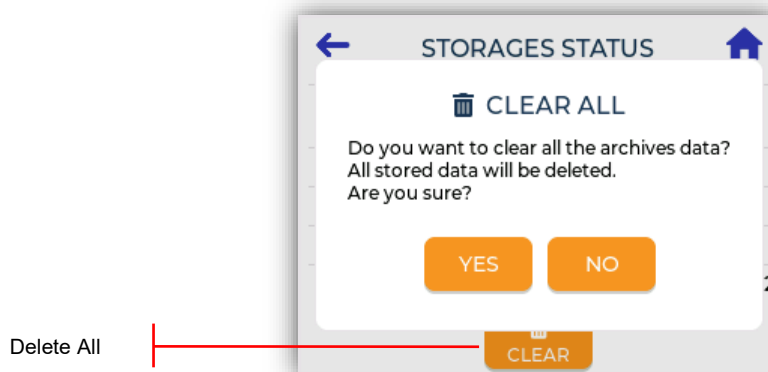

3.2.7 Service Functions

The **SERVICE** page allows access to the data logger's service functions. Since these operations can alter the system's behavior, access is restricted to users with appropriate permissions.



Service screen

From this screen, you can access:

1. PARAMETERS – Modify configuration parameters.
2. CONFIGURATION – Managing the data logger's configuration.
3. APPLICATION – Updating the application firmware.
4. MAINTENANCE – Maintenance service.
5. LOG – Log.
6. SYSTEM – System settings.

3.2.8 Parameters

The **PARAMETERS** page displays the list of parameters defined in the data logger configuration. Each parameter is identified by:

- Numeric ID
- Name
- Value

The values associated with the parameters are used within the configuration to manage various functions, such as calculation expressions, alarm thresholds, time intervals, and other operational logic.

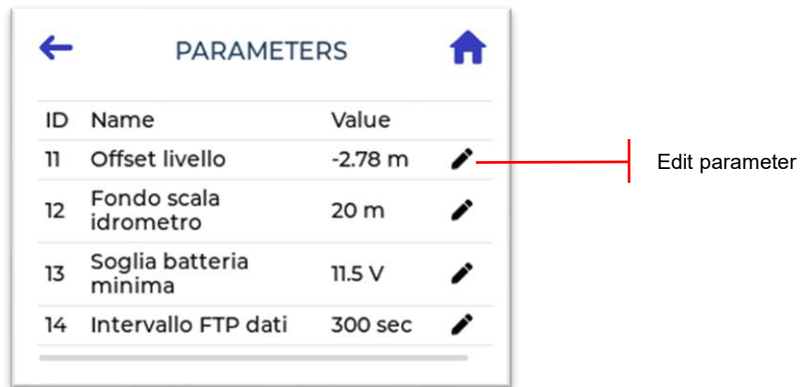

Parameters screen

To change the value of a parameter:

1. Tap the **Edit** icon next to the parameter you want to change (the edit window will open).
2. Use the numeric keypad to enter or change the value.
3. Press OK to confirm and save the change.



Edit parameter

3.2.9 Configuration

The **CONFIGURATION** page displays the status of the configuration and settings files currently in use in the data logger (*cnf.xml* and *ini.xml*). The following information fields are displayed for each file:

- Name.
- Date of last modification.
- Size (KB).

If the screen does not display any files, it indicates that the data logger has not yet been configured.

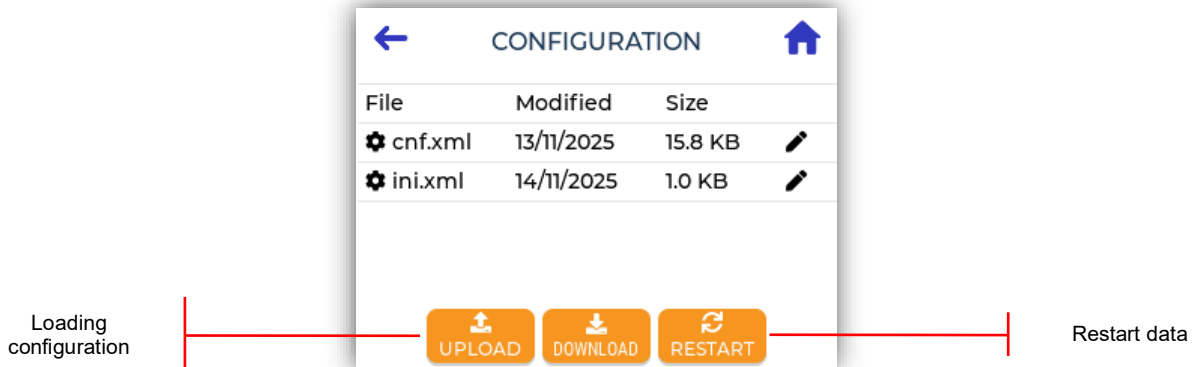

Configuration screen

Using the **UPLOAD** and **DOWNLOAD** buttons, the user can manage the uploading and downloading (copying) of files, respectively, using an external storage device.

Configuration upload procedure

To upload a new configuration (or settings) file, proceed as follows:

1. Insert the external storage device (SD card or USB drive) containing the files to be uploaded.
2. Press the **UPLOAD** button. A dialog box will open to browse the device.
3. Select the new file (.xml) to transfer and press **OK**.

When the next message appears, press **YES** to confirm your selection (or *Cancel* to cancel the operation):

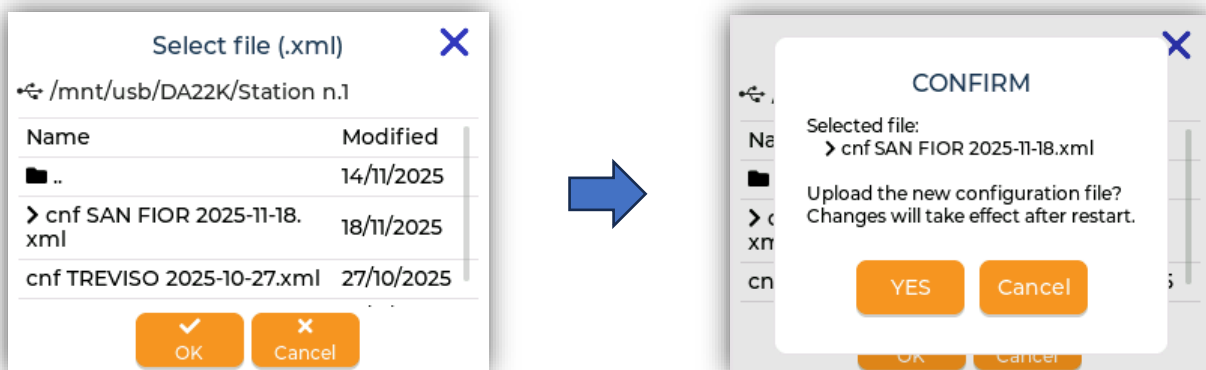

Select new configuration file

After confirmation, the new file will appear in the list as **new_cnf.xml** or **new_ini.xml**.

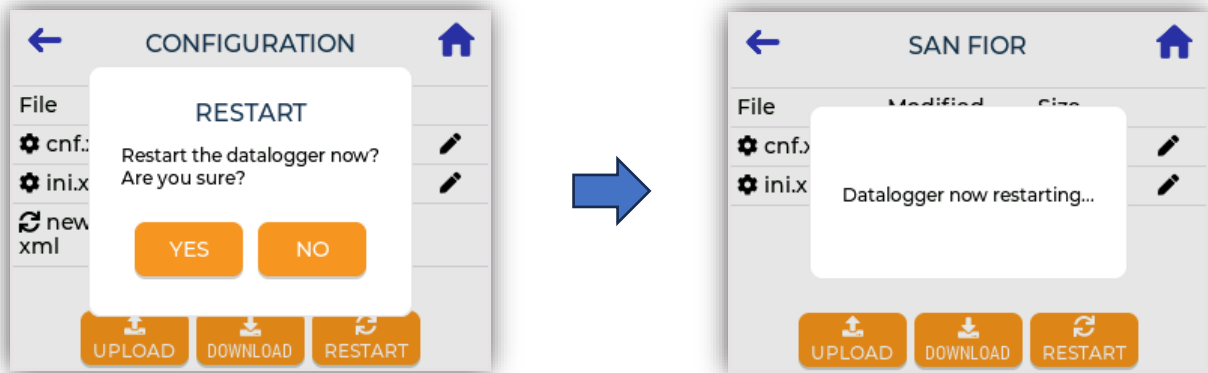

To apply the changes, you must restart the software application when finished. Press the RESTART button and confirm the  restart with YES:



Datalogger restart – Configuration upload

Configuration download procedure

To make a copy of both the configuration and settings files, proceed as follows:

1. Insert the external storage device (SD card or USB drive) where you want to save the files.
2. Press the  DOWNLOAD button. A dialog box will open to browse the device.
3. Select the destination folder path where you want to save the files and press OK 

The following message will confirm the success of the operation:

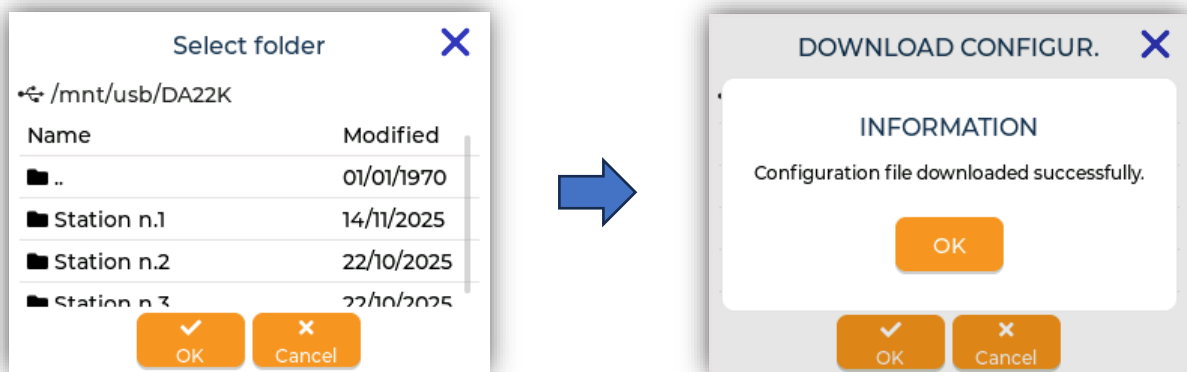

Folder Selection - Configuration Download

The files will be saved with the following naming convention:

- **cnf <station name> <year-month-day>.xml**
- **ini <station name> <year-month-day>.xml**

3.2.10 Application firmware

The **APPLICATION** page displays information regarding the application firmware currently running on the data logger. Specifically:

- File name and version (da20k).
- Date of last modification.
- File size (MB).

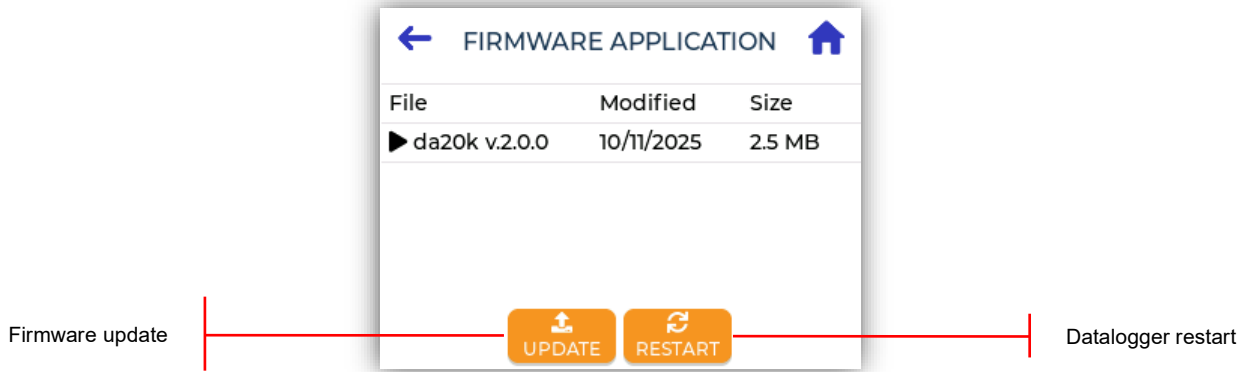



Application firmware screen

The application firmware can be easily updated by using an external storage device to transfer the new file (da20k v***.zip).

Firmware Update Procedure

To upgrade to new firmware, proceed as follows:

1. Insert the external storage device (SD card or USB drive).
2. Press the UPDATE  button. A dialog box will open to browse the device.
3. Select the new file (da20k v***.zip) and press OK 

At the next prompt, press YES to confirm your selection (or *Cancel* to cancel the operation).

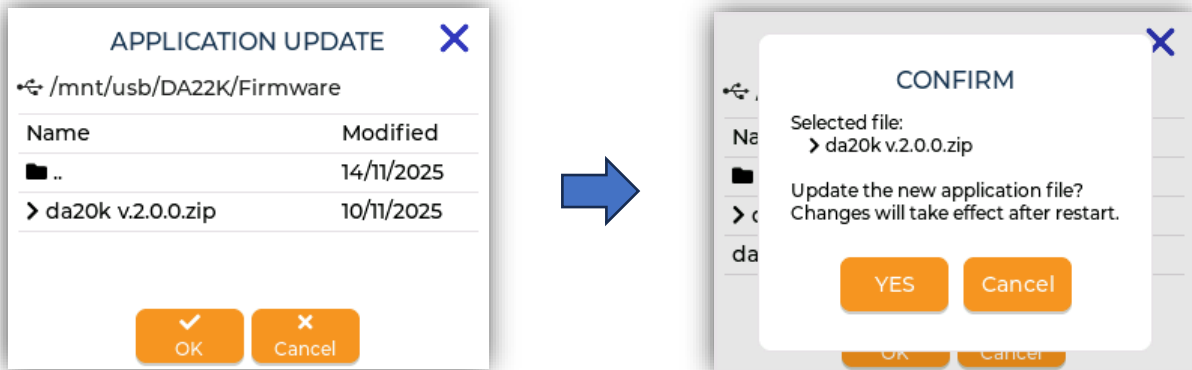

Select new application file

After selection, the screen will show that the new **da20k.zip** file has been loaded but not yet replaced. To apply the update, you must restart the software. Press the RESTART button and then confirm the restart with YES:

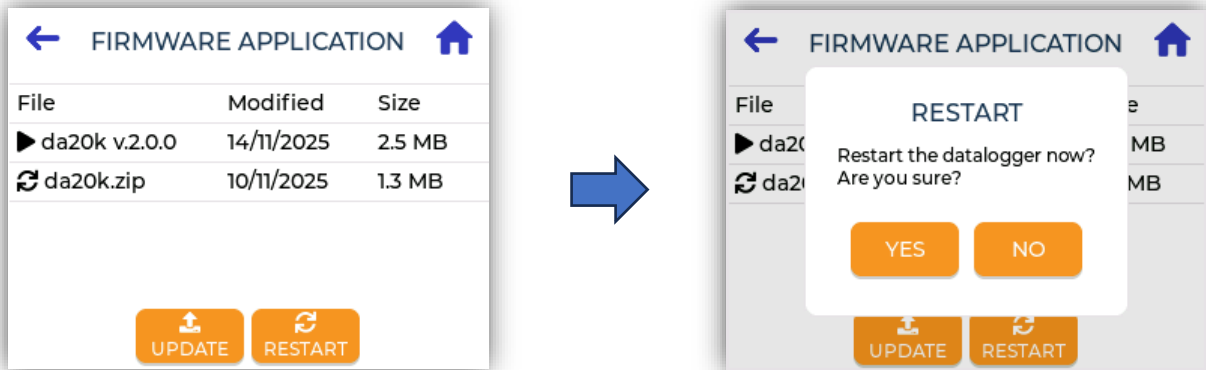

Datalogger Restart – Application Firmware Update

3.2.11 Maintenance

The **MAINTENANCE** function allows maintenance personnel to temporarily stop the data logger service to perform maintenance on the measurement sensors.

To pause the data logger service, confirm the request by pressing YES. The  display will automatically switch to the current measurements screen, which will appear in PAUSE status:

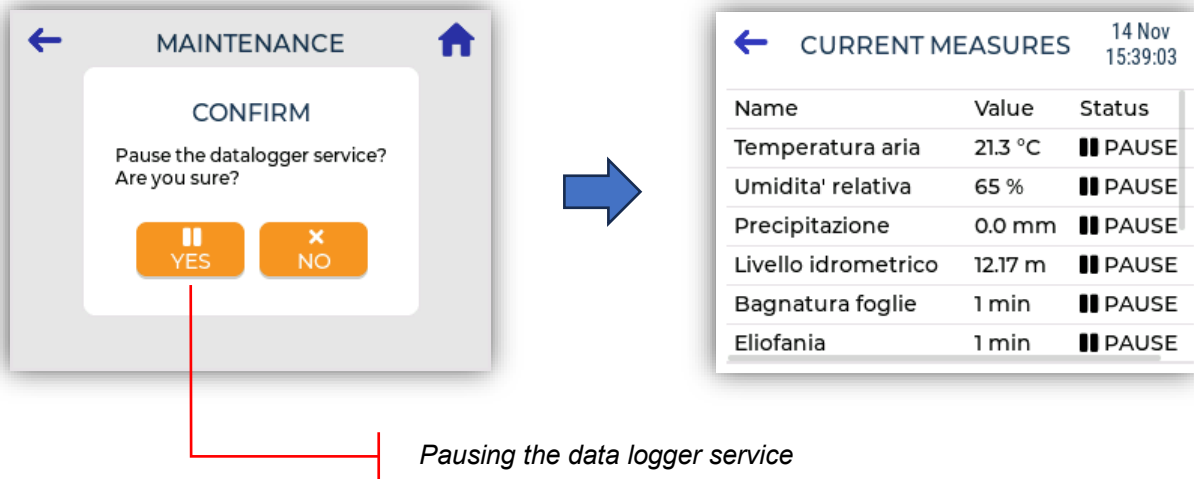

In this mode, the data logger disables data recording to prevent the acquisition of inaccurate measurements.

Once complete, the service can be reactivated by going back and confirming the restart  with YES:

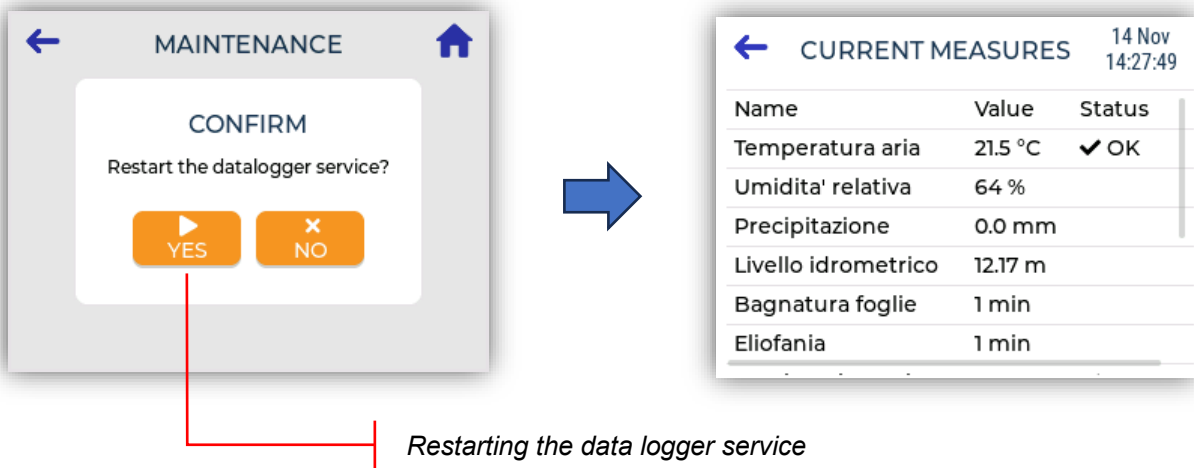

If the service is not restarted, it will automatically restart after 4 hours of inactivity.

3.2.12 Log

The **LOG** page displays application events recorded during operation in real time.

Messages are classified by type:

- **[info]** – General information such as connection status, startup logs, and operational messages;
- **[warning]** – Alerts regarding the operation of the data logger;
- **[error]** – Communication errors, anomalies, or malfunctions;

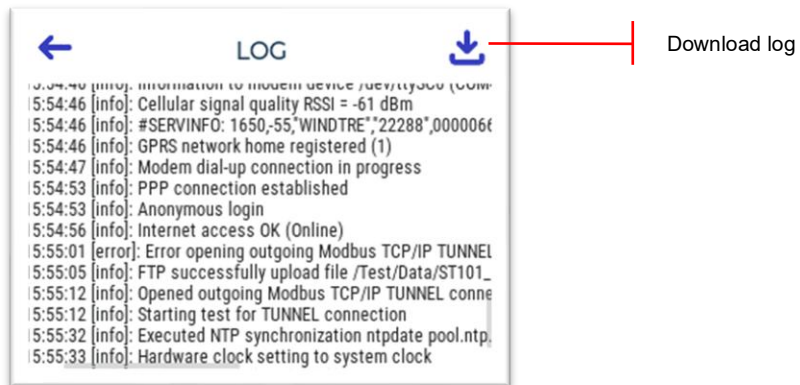

To view the messages properly, you can scroll through the list both vertically and horizontally.



Log screen

From this screen, you can download a copy of the log files to an external storage device (SD card or USB drive). The generated file will contain logs from the last 30 days and is provided in compressed tar.gz format.

Log download procedure

8. Insert the external storage device.
9. Tap the download  icon. A dialog box will open to browse the device.
10. Select the destination folder path where you want to save the files and press OK 

The following message will confirm the success of the operation:

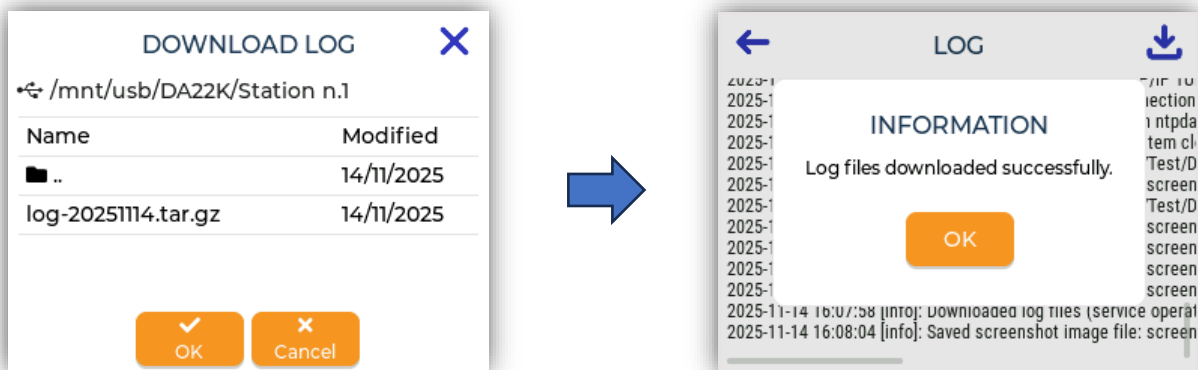

Download log file

3.2.13 System

Access to the **SYSTEM** page is restricted to users with administrator privileges and allows you to directly modify certain system settings.

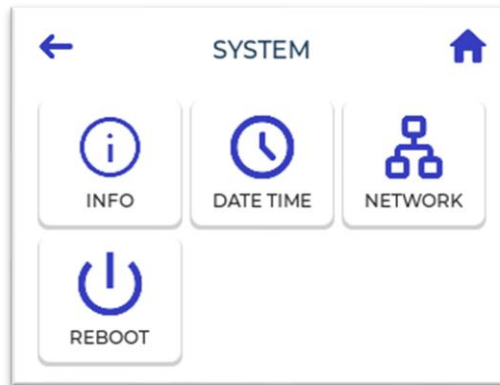

System screen

From this screen, you can access:

1. INFO – System information (Linux Embedded).
2. DATE & TIME – Clock settings.
3. NETWORK – Network interface settings.
4. REBOOT – System reboot.

3.2.14 System Information

The **SYSTEM INFO** page allows you to view information about the status of the running Linux Embedded system.

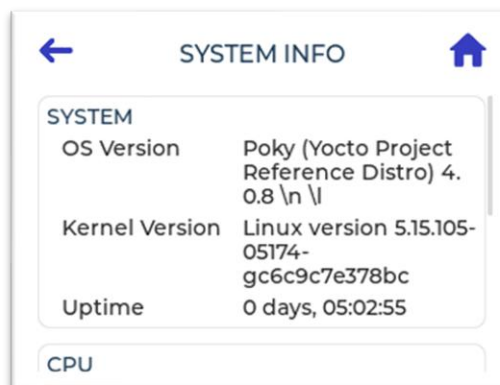

System Information Screen

Specifically:

- System Information
 - Operating System Version;

- Kernel version;
- Total uptime;

CPU

- Hardware model;
- Usage percentage;
- Internal temperature (if available);
- Average load indicators;

Memory and Storage

- Total and used RAM;
- Disk swap;
- File system space (total and used);
- SD card space (total and used);

3.2.15 Date & Time

The **SYSTEM CLOCK** page allows you to set the system clock and local time zone.

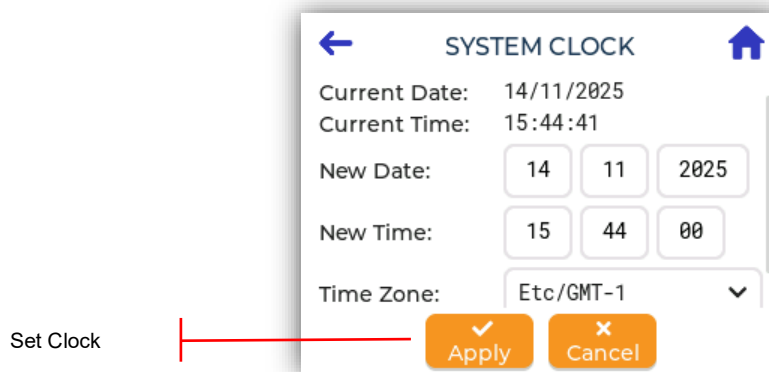

Clock screen

To change the date and time, scroll/rotate the respective fields up or down:

New date: **day, month, year**

New time: **hour, minutes, seconds**

To change the time zone, select the option from the drop-down list (*Time Zone*).

When finished, press the *Apply* button to permanently save the changes. ✓

The changes are applied to both the system clock and the internal hardware clock (RTC), which will then be synchronized with each other.

Important! The data logger settings, normally contained in the *ini.xml* file, include both automatic clock synchronization (NTP) and the local *time zone*, so changes made through this page will be overwritten upon the first system reboot or the first time update.

Note: For technical reasons, it is recommended to set only *time zones* of the **Etc/GMT±h** type, i.e., those that do not observe daylight saving time (DST). Furthermore, as in all POSIX/Linux systems, the convention regarding the sign of the time to be added or subtracted is the opposite of the one commonly used (e.g., GMT-1 corresponds to UTC+1).

3.2.16 Network

The **NETWORK** page can be used to configure the Ethernet network interface (eth0).

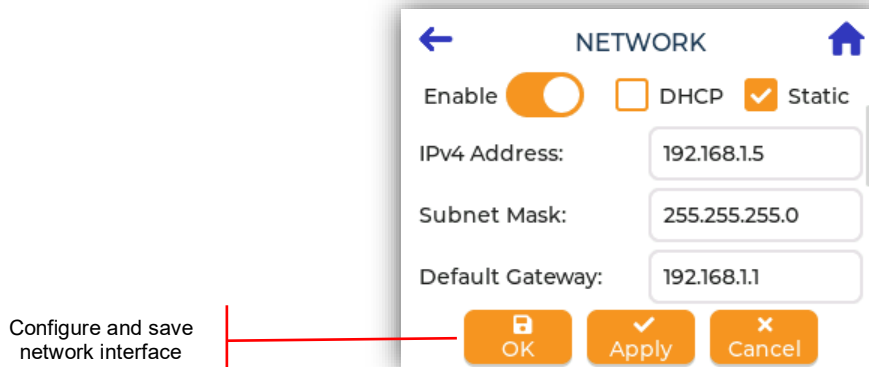

Network screen

If the network is enabled, you can modify and save the following settings:

Mode

- DHCP (automatically obtains an IP address);
- Static (uses the set IP address);

Address

- IPv4 Address;
- Subnet Mask;
- Default gateway;

DNS Server

- Primary DNS;
- Secondary DNS;

3.2.17 Reboot

The **REBOOT** button allows you to restart the operating system. Press  YES to confirm the restart.

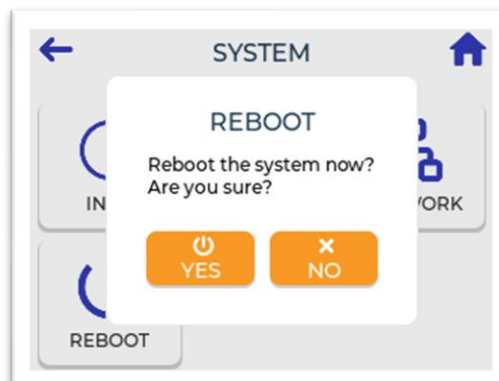

Reboot screen

3.3 Data Logger Configuration

The configuration settings required for the data logger to function are contained in the following files:

- **ini.xml** Initialization file
- **cnf.xml** Configuration file

Upon startup, the data logger application loads these settings and uses them as operating instructions for the program. Note that data loggers with factory settings do not include these files.

The content of each file is structured in XML and is generally generated and sent to the data logger via configuration management software. Alternatively, the files can also be created or edited manually using a text editor compatible with the XML format.

For configuration creation and management, please use the **DAK** application software, referring to the instructions provided in the **s012-d DAK** manual—**DA22K/DA22KE Series Data Logger Programming Manual**.

The following sections describe in detail all supported XML elements. For demonstration purposes, examples of the files are shown using the **Notepad++** editor.

3.3.1 Initialization File

The **ini.xml** initialization file is used to define the device's basic settings, specifically for station identification and for configuring the data logger's communication ports. The settings are organized within the following XML sections:

```
<SYSTEM>
  <INI>
    ...
  </INI>
</SYSTEM>
```

```

1  <?xml version="1.0" encoding="ISO-8859-1"?>
2  <!--Setting created by S+M DAK v 3.7 on 23/set/2024 10:00:00-->
3  <SYSTEM>
4  <INI device-id="1" storage-id="101" station-name="Stazione idrometrica" time-zone="Etc/GMT-1">
5  <BACKUP enable="1" path1="/mnt/sd" path2=""/>
6  <CONNECTIONS>
7  <TCP port="502" protocol="2" max="1"/>
8  <COM1 bps="9600" protocol="2" rts="3"/>
9  <TUNNEL ip="95.110.175.222" port="30101" protocol="2" echo="A" scan="10"/>
10 </CONNECTIONS>
11 <PPP isp-name="internet" persist="1" test-url="www.google.com"/>
12 <NTP sync="360" server="pool.ntp.org"/>
13 <RTC sync="60"/>
14 <WD scan="1" run-timeout="60" data-timeout="21600"/>
15 <MODEM info="AT+CSQ;AT#SERVINFO"/>
16 </INI>
17 </SYSTEM>
18
```

Example of the *ini.xml* file

The following is a detailed description of all the elements that can be included in the initialization file. Some attributes may take default values if omitted.

General and Geographic Settings

- **device-id**: device identifier (MODBUS communication ID). Range: 1–247, Default = 1.
- **storage-id**: data storage identifier (Station ID). Range: 1 to 9999, Default = *device-id*.
- **station-name**: station name.
- **org**: owner organization.
- **lat**: latitude (DD).
- **lon**: longitude (DD).
- **alt**: altitude (m.a.s.l.).
- **time-zone**: local time zone (IANA standard). Default = UTC

Notes:

The most commonly used time zone format is of the type *Continent/City* (e.g., *Europe/Rome*), but these formats automatically adopt the switch to daylight saving time (DST).

To avoid DST, you must use time zones of the form: *Etc/GMT*, *Etc/GMT-1*, *Etc/GMT+1*, etc. In this case, no automatic clock adjustments will be made throughout the year, and the time reference will remain constant.

It is important to note that the notation used by Linux/Posix for time zones of the type *Etc/GMT* is the opposite of the commonly used convention. Specifically:

Etc/GMT-1 corresponds to GMT+01 (one hour ahead of UTC)

Etc/GMT+1 corresponds to GMT-01 (one hour behind UTC)

Users with display access

<USERS/>

- **name**: username;
- **pwd**: password hash (\$1\$...);
- **level**: access level (0=Standard, 1=Owner, 2=Administrator);

This setting enables the login screen, requiring the entry of login credentials (username and password).

Incoming connection for serial communication with the data logger ⁽¹⁾

<COMx/>

- **bps**: serial speed (baud rate: 1200, 2400, 4800, 9600, 19200, 38400, 57600, 115200);
- **protocol**: communication protocol (1=S&F, 2=MODBUS, 3=SDS TETRA, 4=PSE) ⁽²⁾ ;
- **rts**: RTS () setting (0=Disable, 1=Enable, 2=Handshake, 3=Toggle). Default = 3;

This setting enables the COMx serial port to receive data (e.g., COM1).

Incoming connection for TCP/IP communication with the data logger ⁽¹⁾

<TCP/>

- **ip**: specific IP address to listen on (optional). Default = "" (all);
- **port**: TCP port to listen on (Default = 502);
- **protocol**: communication protocol (1=S&F, 2=MODBUS, 3=SDS TETRA, 4=PSE) ⁽²⁾ ;
- **max**: maximum number of accepted connections (. Default = 3;

This setting enables the opening of a *TCP/IP server* listening on the specified port (e.g., 502).

Outgoing connection to a remote tunnel server

<TUNNEL/>

- **ip**: IP address of the Tunnel server to which the data logger must connect;
- **port**: TCP port of the Tunnel server (left side for the station);
- **protocol**: communication protocol (1=S&F, 2=MODBUS, 3=SDS TETRA, 4=PSE) ⁽²⁾ ;
- **echo**: *keep-alive* " " sent periodically to keep the connection active (default = "A");
- **scan**: *keep-alive* transmission interval (Default = 10 sec.)

This mode allows the data logger to be reached via a port-to-port TCP/IP connection on a server running the *Sockets Tunnel* software.

Data backup to external storage devices (SD Memory Card and/or USB Flash Drive)

<BACKUP/>

- **enable**: Enable backup copying (0=Disable, 1=Enable).
- **path1**: mount path */mnt/sd* for backup to SD Card (primary drive);
- **path2**: mount point */mnt/usb* for backup to USB disk (secondary drive);
Default = " (not present);

3G/4G Modem

<MODEM/>

- **com**: serial port to which the modem is connected (Default: 4 = COM4);
- **baud**: modem serial speed (Default: baudrate = 38400);
- **info**: specifies one or more additional AT commands to obtain information on the RSSI signal, network registration, mobile carrier, etc. (e.g., "AT+CSQ;AT#SERVINFO");

PPP (Point-to-Point Protocol) Connection

<PPP/>

- **isp-name**: name of the PPP connection configuration file. The file must be located in the system directory: */etc/ppp/peers* (Default: internet);
- **persist**: specifies whether the PPP connection should be persistent (1 = always active) or activated on demand (0 = only when requested), for example, before initiating an FTP data transfer. Note: if a tunnel connection is present, PPP persistence must be enabled;
- **test-url**: URL or remote IP address used to test Internet access (Default = www.google.com);

DDNS (Dynamic Domain Name System) Client

<DDNS/>

- **url**: Specific URL for updating the IP address (e.g., <https://dynupdate.no-ip.com/nic/update>)
- **username**: username registered with the service;
- **password**: login password;
- **hostname**: associated domain name;

The DDNS service allows you to automatically associate a domain name with the data logger's dynamic IP address even if the address changes over time (e.g., domain: *da22k-0001-siapmicros.ddns.net*).

NTP (Network Time Protocol) Client

<NTP/>

- **sync**: synchronization interval (minutes); Default: 360 minutes;
- **server**: time server name (Default time server: pool.ntp.org)

NTP is used to update the data logger's clock with a precise time reference from a network time server. NTP synchronization updates both the system clock and the RTC hardware clock.

RTC (Real-Time Clock) Device

<RTC/>

- **sync**: synchronization interval (minutes); Default: 60 minutes;

RTC is an internal hardware component used to synchronize the system clock with a more precise time reference.

Hardware Watchdog

<WD/>

- **scan**: pulse period of the WD digital output (seconds). The pulse is intended for the datalogger's main board watchdog (RUN LED). If the pulse is not received, the board cuts power to reset the datalogger.
- **run-timeout**: maximum inactivity time for the main loop (Default: 60 seconds);
- **data-timeout**: maximum time without data transfer. Set to 0 to disable the check (Default: 86,400 seconds);

The hardware watchdog is used to ensure the device operates correctly. It resolves situations where the system is frozen or unresponsive by automatically restarting it.

If the set maximum times expire (timeout), the internal process sends a specific pulse sequence that immediately triggers the Watchdog, resulting in a restart of the data logger.

⁽¹⁾ Default connection: If no incoming connections are configured, the data logger will still be accessible via:

- Serial port COM1 at 9600 bps using the *Modbus RTU* protocol
- TCP/IP port 502 listening on the *Modbus TCP/IP* protocol

⁽²⁾ The following protocols are not currently available:

- S&F (obsolete)
- SDS TETRA (not implemented)

3.3.2 Configuration file

The **cnf.xml** configuration file contains the settings and functions programmed by the user to define the data logger's operating cycle.

The settings are organized within the following XML sections:

<CONFIG>	
<PARAMETERS>	<i>Definition of parameters used in the configuration</i>
<ACQUISITIONS>	<i>Configuration of sensor acquisition and measurement channels</i>
<PROCESSING>	<i>Implementation of data processing functions for acquired data</i>
<CONTROLS>	<i>Output control logic and operating conditions</i>
<STORAGES>	<i>Configuration of data storage type and format</i>
<TRANSMISSIONS>	<i>Configuration of data transmission channels</i>
<DISPLAY>	<i>Setting the measurements displayed on the local interface</i>
</CONFIG>	

```

1  <?xml version="1.0" encoding="ISO-8859-1"?>
2  <!--Configuration created by S+M DAK v 3.7 on 23/set/2024 10:00:00 ClassLib v. 1.3.0-->
3  <CONFIG>
4  <REMARKS>
5  <REMARK name="1.0.0" ClsId="REMARK" author="SIAP+MICROS" note="Configurazione stazione idrometeo"/>
6  </REMARKS>
7  <PARAMETERS>
8  <PARAMETER name="Offset livello" ClsId="PARAMETER" id="11" unit="m" value="-2.78"/>
9  <PARAMETER name="Fondo scala idrometro" ClsId="PARAMETER" id="12" unit="m" value="20"/>
10 <PARAMETER name="Soglia batteria minima" ClsId="PARAMETER" id="13" unit="V" value="11.5"/>
11 <PARAMETER name="Cadenza FTP dati" ClsId="PARAMETER" id="14" unit="sec" value="300"/>
12 </PARAMETERS>
13 <ACQUISITIONS>
14 <SENSOR name="Scheda BASE15K - Misure ingressi analogici/digitali" ClsId="BASE15K_AI" type="2" id="1" com="2" baud="57600" scan=
15 <CHANNEL name="TAN" ClsId="PT100_CH01" enab="1" addr="300001" type="5" expr="" low="-30" upp="60" tag="30"/>
16 <CHANNEL name="RHN" ClsId="SING_CH05" enab="1" addr="300017" type="5" expr="(M0*1e-6)+100" low="0" upp="100" tag="32"/>
17 <CHANNEL name="RLS" ClsId="SING_CH08" enab="1" addr="300023" type="5" expr="$12*(M0*1e-6-0.4)/1.6" low="0.30" upp="20" tag="
18 <CHANNEL name="PLUV" ClsId="COUNT_DIA03" enab="1" addr="300063" type="3" expr="M0*0.2" low="0" upp="+2E9" tag="40"/>
19 <CHANNEL name="VBAT" ClsId="V_BATT" enab="1" addr="300079" type="5" expr="" low="0" upp="24" tag="48"/>
20 </SENSOR>
21 <SENSOR name="Acquisizione interna" ClsId="SYSTEM" type="0" scan="10000">
22 <CHANNEL name="LIV" ClsId="GET_TAG" addr="0035" type="0" expr="($12-M0)+$11" low="-5" upp="15" tag="36"/>
23 </SENSOR>
24 </ACQUISITIONS>
25 <PROCESSINGS>
26 <PROCESSING name="Elab. PLUV" ClsId="ELAB_PLUV" type="3" scan="300" shift="0" rate="0" tag_inpl="0040" tag_outl="100" tag_out2="
27 <PROCESSING name="Elab. P24H" ClsId="ELAB_PLUV" type="3" scan="86400" shift="0" rate="0" tag_inpl="0040" tag_outl="111" tag_out2
28 <PROCESSING name="Elab. TA" ClsId="ELAB_STD" type="1" scan="1800" shift="0" rate="50" param1="0" param2="0" tag_inpl="0030" tag_
29 <PROCESSING name="Elab. RH" ClsId="ELAB_STD" type="1" scan="1800" shift="0" rate="50" param1="0" param2="0" tag_inpl="0032" tag_
30 <PROCESSING name="Elab. LIV" ClsId="ELAB_STD" type="1" scan="900" shift="0" rate="50" param1="0" param2="0" tag_inpl="0036" tag_
31 <PROCESSING name="Elab. VBAT" ClsId="ELAB_STD" type="1" scan="1800" shift="0" rate="50" param1="0" param2="0" tag_inpl="0048" ta
32 </PROCESSINGS>
33 <CONTROLS>
34 <ALARM name="Batteria scarica" ClsId="ALARM_MEASURE" type="0" scan="10" tag_inpl="0048" min="$13" prn="" prx="" max="" ret="0.5"
35 </CONTROLS>
36 <STORAGES>
37 <RECORD name="Record istantanei" ClsId="RECORD" id="" type="1" format="0" scan="10" shift="0" file="1" merge="0" backup="0" view
38 <WRITE name="TA ist" ClsId="DATA_FIELD" id="1" type="A" tag="0030" unit="°C" dec="1" hide="0" sts=""/>
39 <WRITE name="RH ist" ClsId="DATA_FIELD" id="2" type="A" tag="0032" unit="%" dec="0" hide="0" sts=""/>
40 <WRITE name="PLUV sum" ClsId="DATA_FIELD" id="3" type="A" tag="0108" unit="mm" dec="1" hide="0" sts=""/>
41 <WRITE name="LIV ist" ClsId="DATA_FIELD" id="4" type="A" tag="0036" unit="m" dec="2" hide="0" sts=""/>
42 <WRITE name="VBAT ist" ClsId="DATA_FIELD" id="8" type="A" tag="0048" unit="V" dec="1" hide="0" sts=""/>
43 </RECORD>
44 <RECORD name="Record allarmi" ClsId="RECORD" id="" type="2" format="0" scan="30" shift="0" file="4" merge="1" backup="0" view="0
45 <WRITE name="VBAT ist" ClsId="DATA_FIELD" id="8" type="A" tag="0048" unit="V" dec="1" hide="0" sts=""/>
46 </RECORD>
47 <RECORD name="Record storici 5'" ClsId="RECORD" id="" type="0" format="0" scan="300" shift="0" file="6" merge="1" backup="0" vie
48 <WRITE name="PLUV sum" ClsId="DATA_FIELD" id="3" type="B" tag="0108" unit="mm" dec="1" hide="0" sts=""/>
49 </RECORD>
50 <RECORD name="Record storici 15'" ClsId="RECORD" id="" type="0" format="0" scan="900" shift="0" file="6" merge="1" backup="0" vi
51 <WRITE name="LIV med" ClsId="DATA_FIELD" id="4" type="B" tag="0216" unit="m" dec="2" hide="0" sts=""/>
52 <WRITE name="LIV max" ClsId="DATA_FIELD" id="4" type="C" tag="0217" unit="m" dec="2" hide="0" sts=""/>
53 <WRITE name="LIV dev" ClsId="DATA_FIELD" id="4" type="D" tag="0219" unit="m" dec="2" hide="0" sts=""/>
54 <WRITE name="LIV dev" ClsId="DATA_FIELD" id="4" type="D" tag="0222" unit="m" dec="6" hide="0" sts=""/>
55 <WRITE name="LIV ist" ClsId="DATA_FIELD" id="4" type="A" tag="0225" unit="m" dec="2" hide="0" sts=""/>
56 </RECORD>
57 <RECORD name="Record storici 30'" ClsId="RECORD" id="" type="0" format="0" scan="1800" shift="0" file="6" merge="1" backup="0" v
58 <WRITE name="TA med" ClsId="DATA_FIELD" id="1" type="B" tag="0160" unit="°C" dec="1" hide="0" sts=""/>
59 <WRITE name="TA min" ClsId="DATA_FIELD" id="1" type="C" tag="0161" unit="°C" dec="1" hide="0" sts=""/>

```

Example cnf.xml file

The following sections describe the settings and configurable functions in detail.

3.3.3 Main cycle and secondary processes

All priority functions for data **acquisition, processing, and storage** are performed by the data logger application within a **main work cycle**.

The execution sequence of the main cycle consists of the following operational steps, in order:

- 1° Data Acquisition
- 2° Data processing
- 3° Checks
- 4° Data storage
- 5° Data transmission

When creating the configuration file, the functions are defined in the order described above.

The exception is the measurement acquisition process, which is further divided into *parallel threads*, one for each serial or TCP/IP communication port to which the sensors are connected.

Secondary processes

Additional functions that require longer execution times or that could block the main cycle are handled via **separate work processes** (secondary threads).

These include, in particular, data transmission functions and the management of the data logger's communication devices.

Secondary processes executed in parallel include:

- Serial communication thread: management of data reception on **COM1 ... COM4** ports
- TCP/IP communication thread: management of incoming **TCP/IP** connections
- Dial-up modem connection process: **PPP** protocol management
- **Tunnel** server connection process: management of dedicated communication channel
- **FTP** file transfer process: file upload and download
- Date/time synchronization process: synchronization via **NTP** protocol and **RTC** management
- Display process: updating data on the control panel

3.3.4 User parameters

The **parameters** section allows you to define and store a set of user-defined parameters in the configuration file. Parameter values can be modified locally via the data logger display (see section [3.2.8 – Parameters](#)).

Parameters can be used in the following contexts:

- as flags to enable/disable measurements or other functions;
- within measurement conversion expressions or any other evaluation expression;
- as measurement offsets or alarm thresholds;
- as time intervals for data processing and/or storage;
- for managing phone numbers, IP addresses, or other configuration values.

Referencing parameters in the configuration

To reference a parameter within the configuration file, use the following notation:

\$id

where ***id*** represents the numerical identifier of the parameter, preceded by the **\$** symbol

Examples: \$11, \$12, \$13

XML example of the PARAMETERS section:

```
<PARAMETERS>
  <PARAMETER name="Level Offset" id="11" unit="m" value="-2.78"/>
  <PARAMETER name="Hydrometer full scale" id="12" unit="m" value="20"/>
  <PARAMETER name="Minimum battery threshold" id="13" unit="V" value="11.5"/>
  <PARAMETER name="FTP data rate" id="14" unit="sec" value="300"/>
</PARAMETERS>
```

Parameter Configuration

The XML element `< PARAMETER ... />` includes the following attributes:

- **id** – numerical identifier of the parameter;
- **name** – parameter name;
- **unit** – unit of measurement;
- **value** - assigned value;

3.3.5 *tion of measurements*

The **measurement acquisition** section allows you to configure the **sensors and/or acquisition devices** connected to the data logger, each with its own communication settings.

Within each sensor, the **measurement channels** to be queried during the acquisition cycle are defined. The raw data obtained from the query undergoes a **pre-processing** phase, which includes:

- conversion to engineering units (if necessary);
- a validity check within the measurement range.

The resulting data is then made available in the assigned memory locations (*tags*).

Below is an example of the XML structure describing the acquisition section for multiple sensors:

```

<ACQUISITIONS>
  <SENSOR name="BASE Board ..." type="2" id="1" com="2" baud="57600" scan="3000" timeout="500">
    <CHANNEL name="TAN" enab="1" addr="300001" type="5" expr="" low="-30" upp="60" tag="30"/>
    <CHANNEL name="RLS" enab="1" addr="300023" type="5" expr="$12*(M0*1e-6-0.4)/1.6" low="0... tag="35"/>
    <CHANNEL name="PLUV" enab="1" addr="300063" type="3" expr="M0*0.2" low="0" upp="+2E9" tag="40"/>
    <CHANNEL name="VBAT" enab="1" addr="300079" type="5" expr="" low="0" upp="24" tag="48"/>
  </SENSOR>
  <SENSOR name="Internal Acquisition" CIsId="SYSTEM" type="0" scan="10000">
    <CHANNEL name="LIV" addr="0035" type="0" expr="($12-M0)+$11" low="-5" upp="15" tag="36"/>
  </SENSOR>
</ACQUISITIONS>
  
```

Sensor configuration (XML element < SENSOR ... />)

- **name** – sensor name;
- **type** – sensor type (identifies the communication protocol):
 0. **Internal system** (tag variable, date/time, RSSI signal, connection status)
 1. **Store & Forward** (ISIDL / SISLP)
 2. **MODBUS Standard**
 3. **SDI-12 Standard**
 4. **Generic Serial ASCII**
 5. <reserved for future use>
 6. <reserved for future use>
- **id** – alphanumeric identifier of the sensor's hardware address (e.g., Modbus ID: 1–247);
- **com** – communication port to which the sensor is connected:
 0. LAN (TCP/IP sensor)
 1. COM1 RS-232
 2. COM2 RS-485
 3. COM3 RS-485
 4. COM4 RS-232
 5. COM5 SDI-12 (D1)
 6. COM6 RS-485
 7. COM7 RS-485
 8. COM8 RS-232
 9. COM9 SDI-12 (D2)
- **baud** – serial communication speed: 1200, 2400, 4800, 9600, 19200, 38400, 57600, 115200 bps

- **par** – parity: N = None, E = Even, O = Odd; (default: N);
- **data** – number of data bits: 8 – 7 bits; (default: 8);
- **stop**: stop bits: 1 – 2 bits; (default: 1);
- **ip** – IP address (TCP/IP sensor);
- **port** – port (TCP/IP sensor);
- **cmd** – query command (e.g., M! for SDI-12 sensor);
- **head** – ASCII message header;
- **tail** – the end of the ASCII message;
- **delims** – delimiter characters in the ASCII message (one or more characters used to separate values);
- **scan** – interval, in milliseconds, at which the sensor is queried (in some cases, the scan interval may be defined separately for each channel);
- **timeout** – maximum response wait time (milliseconds);
- **delay** – delay/pause after acquisition (milliseconds);

Channel configuration (XML element <CHANNEL .../>)

- **name** – channel name;
- **enab** – channel enable flag (1 = Scanning, 0 = Not scanning);
- **addr** – channel address (for tag variable acquisitions, identifies the internal memory location; for MODBUS sensors, identifies the read address according to the standard data addressing convention⁽¹⁾; for SDI-12 sensors, identifies the value's position in the response).
- **type** – data type:
 - Internal system: 0 = Tag variable, 1 = Date/time, 2 = Digital input I0–I3, 3 = Modem RSSI signal, 4 = Connection status
 - Modbus data: 0 = Boolean (0/1), 1 = Signed (16-bit), 2 = Unsigned (16-bit), 3 = Swapped Long (32-bit), 4 = Long integer (32-bit), 5 = Swapped Little-endian Floating-Point (CDAB), 6 = Big-endian Floating-Point (ABCD)
- **scan** – the interval, in milliseconds, at which the channel is polled (if not already specified at the sensor level).
- **conv** – pre-conversion expression for the acquired signal (optional);
- **expr** – conversion expression or correction formula to be applied to the acquired signal to obtain the measurement value in engineering units;
- **low** – lower limit of the measurement range (*lower limit*);
- **upp** – upper limit of the measurement range (*upper limit*);
- **tag** – memory location where the acquired measurement is stored (*tag*);

⁽¹⁾ Addressing convention for MODBUS data reading:

- (0x) 000001..065536 Function 1: Read Output Coils
- (1x) 100001..165536 Function 2: Read Discrete Inputs
- (3x) 300001..365536 Function 4: Read Input Registers
- (4x) 400001..465536 Function 3: Read Holding Registers

Note: The starting address and the number of registers/coils to be requested are calculated automatically based on the channels entered.

3.3.6 Processing Functions

The **processing** section, immediately following the acquisition phase, handles the processing of the acquired measurements at configurable time intervals. **Valid samples** of the input measurements (*tag_inp*) are fed into the respective processing function for processing.

At the end of the configured interval, each function returns a set of **statistical data** (averages, minimums, maximums, etc.), which are made available at the assigned output locations (*tag_out*).

Example of an XML section dedicated to processing (PROCESSINGS):

```

<PROCESSINGS>
  <PROCESSING name="Rain Processing" type="3" scan="300" shift="0" rate="0" tag_inp1="0040" tag_out1="100"
  .../>
  <PROCESSING name="TA Processing" type="1" scan="1800" shift="0" rate="50" tag_inp1="0030" tag_out1="156"
  .../>
  <PROCESSING name="HR Processing" type="1" scan="1800" shift="0" rate="50" tag_inp1="0032" tag_out1="170"
  .../>
</PROCESSINGS>
  
```

Processing Configuration

The XML element < PROCESSING ... /> includes the following attributes:

- **name** – name of the processing;
- **type** – processing type:
 1. **Statistical processing (standard)**
 2. **Dragging processing (mobile)**
 3. **Rainfall processing (rain)**
 4. **Anemometric processing (wind)**
- **scan** – data processing interval (seconds);
- **shift** – interval offset (seconds);
- **rate** – minimum rate of valid data required;
- **param1...paramN** – set of parameters usable in processing (if provided) ^(*);
- **tag_inp1... tag_inp N** – set of input locations (tags) (measurements).
- **tag_out1...tag_outN** – set of output locations (tags) (data).

^(*) Commonly used parameters:

1. Data Acceptability Criterion: defines the maximum permissible variation range of the incoming sample relative to the previous one. If the range is exceeded, the incoming sample will not be accepted. Setting this to zero disables the criterion.
2. Standard deviation limit: defines the maximum threshold of the calculated standard deviation, above which the output statistical data will be invalidated. If set to zero, invalidation is not applied.

The following pages provide, for each type of analysis, a list of input parameters and the corresponding output locations where the data resulting from the process are made available.

Standard statistical processing

<i>Attribute</i>	<i>Description</i>
param1	→ Data acceptability criterion (maximum permissible variation: 0 = not applied)
param2	→ Standard deviation limit (maximum validation threshold: 0 = not applied)
tag_inp1	→ Instantaneous measurement (input)
tag_out1	← Cyclic counter
tag_out2	← Valid measurement counter
tag_out3	← Percentage of valid measurements [%]
tag_out4	← Sum
tag_out5	← Average
tag_out6	← Minimum
tag_out7	← Lowest minute [daily minute]
tag_out8	← Maximum
tag_out9	← Minute of the maximum [daily minute]
tag_out10	← Variance
tag_out11	← Standard deviation
tag_out12	← Measurement reference (value of the last measurement sample)
tag_out13	← Measurement deviation (deviation of the measurement from the initial sample)
tag_out14	← Last valid measurement snapshot

Drag-and-drop processing (mobile)

<i>Attribute</i>	<i>Description</i>
param1	→ Data acceptability criterion (maximum permissible variation: 0 = not applied)
tag_inp1	→ Instantaneous measurement (input)
tag_out1	← Cyclic counter
tag_out2	← Valid measurement counter
tag_out3	← Percentage of valid measurements [%]
tag_out4	← Moving average
tag_out5	← Moving average
tag_out6	← Moving average
tag_out7	← Moving minimum
tag_out8	← Moving high

Rainfall Analysis

<i>Attribute</i>	<i>Description</i>
tag_inp1	→ Acquired rainfall measurement [mm] (input)
tag_out1	← Cyclic counter
tag_out2	← Valid measurement counter
tag_out3	← Percentage of valid measurements [%]
tag_out4	← Instantaneous rainfall [mm] (current precipitation in the cycle)
tag_out5	← Instantaneous precipitation intensity [mm/h]
tag_out6	← Average precipitation intensity [mm/h]
tag_out7	← Minimum precipitation intensity [mm/h]

tag_out8	←	Maximum precipitation intensity [mm/h]
tag_out9	←	Accumulated rainfall [mm] (precipitation accumulated during the period)
tag_out10	←	Total rainfall [mm] (total accumulated precipitation)
tag_out11	←	Rain gauge test [mm] (rain gauge test precipitation)

Anemometer processing (wind)

<i>Attribute</i>	<i>Description</i>
param1	→ Wind calm threshold [m/s] (typical = 0.5 m/s)
param2	→ Number of wind sectors [0, 8, 16, 36, 360]
param3	→ Max. angle of the dominant sector [°]
param4	→ Minimum rate for dominant sector [%]
tag_inp1	→ Instantaneous speed measurement (input)
tag_inp2	→ Instantaneous direction measurement (input)
tag_out1	← Cyclic counter
tag_out2	← Valid speed measurement counter
tag_out3	← Valid direction measurement counter
tag_out4	← Speed value sum
tag_out5	← Sum of direction sines
tag_out6	← Directional cosine sum
tag_out7	← Sum of sine vector components
tag_out8	← Sum of the cosine vector component
tag_out9	← AVERAGE SPEED (scalar calculation) [m/s]
tag_out10	← AVERAGE DIRECTION (trigonometric calculation) [°N]
tag_out11	← VECTOR SPEED (magnitude of the resultant vector) [m/s]
tag_out12	← VECTOR DIRECTION (resultant vector angle) [°N]
tag_out13	← MINIMUM SPEED VALUE [m/s]
tag_out14	← MINIMUM SPEED MINUTE [Daily Minute]
tag_out15	← MAXIMUM SPEED VALUE [m/s]
tag_out16	← MINUTE OF MAXIMUM SPEED [Daily Minute]
tag_out17	← DIRECTION AT MAXIMUM SPEED [°N]
tag_out18	← SET DIRECTION AT MAXIMUM SPEED [°N]
tag_out19	← Prevailing sector: SECTOR DIRECTION ^(*) [°N]
tag_out20	← Dominant sector: AVERAGE WIND SPEED ^(*) [m/s]
tag_out21	← Dominant sector: MAXIMUM INTENSITY VALUE ^(*) [m/s]
tag_out22	← Dominant sector: MINUTE MAXIMUM INTENSITY ^(*) [Daily minute]
tag_out23	← STANDARD DEVIATION OF SPEED [m/s]
tag_out24	← STANDARD DEVIATION OF DIRECTION [°N]
tag_out25	← LAST SPEED MEASUREMENT [m/s]
tag_out26	← LAST DIRECTION MEASUREMENT [°N]
tag_out27	← Dominant sector: INITIAL EXTREME ^(*) [°N]
tag_out28	← Dominant sector: FINAL EXTREME ^(*) [°N]

(*) Values available only after processing

Calculation of reference evapotranspiration (ET_o) method

Penman-Monteith FAO-56

<i>Attribute</i>	<i>Description</i>	<i>Notes</i>
param1	→ Calculation method (*)	1 = Net solar radiation, 2 = Global solar radiation
param2	→ Elevation [m.a.s.l.]	Elevation above sea level
param3	→ Latitude N/S [°deg]	Positive (North) - Negative (South)
tag_inp1	→ Temperature [°C]	Input measurement
tag_inp2	→ Humidity [%]	Input measurement
tag_inp3	→ Wind speed at 2 meters [m/s]	Input measurement
tag_inp4	→ Solar radiation [W/m ²]	Input measurement
tag_out1	← Evapotranspiration ET _o [mm]	Output data

(*) With net radiation sensor (Net-radiometer) or global radiation sensor (Pyranometer)

3.3.7 Control Section

This section is dedicated to managing **control functions**, specifically **alarms** and **commands for digital and/or analog outputs**, both to external devices and locally on the data logger.

The control functions currently available are:

- **Measurement alarm control**
- **Data rate control**
- **MODBUS output control**
- **MODBUS data mapping**

XML example of the controls section:

```

<CONTROLS>
  <ALARM name="Low battery" type="0" scan="10" tag_inp="0048" min="$13"... max="" ret="0" wait="0" tag... />
  <ALARM name="Door open" type="0" scan="5" tag_inp="0050" min="50" ... max="" ret="0" wait="0" tag... />
  <MODBUS name="BASE Control" type="2" id="1" com="2" baud="57600" par="N" data="8" stop="1" scan="3"...>
    <OUTPUT name="Command" addr="0" type="0" expr="$20<>0" low="-2E9" upp="+2E9" mode="0"/>
  </MODBUS>
</CONTROLS>
  
```

Alarm Control Configuration

Alarm monitoring of the measurement is performed periodically based on the configured scan interval. If the measurement value exceeds, either rising or falling, the respective maximum (or minimum) threshold, and this condition persists for the set duration, a corresponding alarm event will be generated.

The alarm status code is stored in the assigned output location (*tag_out*), making the information available for subsequent storage and transmission phases.

The XML element `< ALARM ... />` includes the following attributes:

- **name** – name of the control;
- **type** – type of check: 0 = MEASUREMENT ALARM
- **scan** – interval at which the check is performed (seconds);
- **shift** – interval offset (seconds);
- **tag_inp** – location of the input tag variable (measurement or data);
- **min** – minimum alarm threshold; default: "" = none;
- **prn** – minimum pre-alarm threshold (warning); default: "" = none;
- **prx** – maximum pre-alarm threshold (warning); default: "" = none;
- **max** – maximum alarm threshold; default: "" = none;
- **ret** – return offset (hysteresis on the threshold); default = 0;
- **wait** – dwell time before alarm activation (seconds); default = 0;
- **act** – rate change activation: 0 = No, 1 = Yes
- **tag_out** – output tag variable location (alarm status);

List of output alarm status codes:

- 2. MINIMUM ALARM
- 1. MINIMUM PRE-ALARM
0. NORMAL
1. MAXIMUM PRE-ALARM
2. MAXIMUM ALARM
3. ACQUISITION ERROR
4. MEASUREMENT OUT OF RANGE
5. MEASUREMENT DISABLED OR OUT OF SERVICE

Frequency Control Configuration

The **sampling rate control** operates by dynamically modifying the time intervals configured in the data processing and storage functions.

This adjustment depends on the system's operating status, which can be **normal**, **warning**, or **alarm**. This allows the recording frequency and subsequent data transmission to be automatically adapted.

For the control to function correctly, the following conditions must be met:

- the relevant intervals are configured and expressed in seconds;
- the intervals are specified using **parameter notation**. For example:
 - \$14 = interval in **normal state**
 - \$15 = interval in **warning state**
 - \$16 = cadence in **alarm state**

The XML element <CONTROL ... /> includes the following attributes:

- **name** – name of the control;
- **type** – type of check: 3 = SCAN CHECK (frequency change)
- **scan** – interval, expressed in seconds, at which the check is performed;
- **cad0** – cadence parameter in **normal state**;
- **cad1** – cadence parameter in **warning state (pre-alarm)**;
- **cad2** – cadence parameter in **alarm state**;
- **tag_out** – output tag variable location (contains the cumulative alarm status);

MODBUS Output Control Configuration

Allows writing to outputs or registers on local or remote MODBUS devices.

The XML element < MODBUS ... /> includes the following attributes:

- **name** – control name;
- **type** – control type: 2 = MODBUS OUTPUT
- **id** – hardware address of the Modbus device (Slave ID: 1–247);
- **com** – communication port to which the device is connected:
 0. LAN (Modbus TCP/IP)
 1. COM1 RS-232
 2. COM2 RS-485
 3. COM3 RS-485
 4. COM4 RS-232
 6. COM6 RS-485
 7. COM7 RS-485
 8. COM8 RS-232
- **baud** – serial communication speed: 1200, 2400, 4800, 9600, 19200, 38400, 57600, 115200 bps
- **par** – parity: N = None, E = Even, O = Odd; (default: N);
- **data** – number of data bits: 8 – 7 bits; (default: 8);
- **stop** – stop bits: 1 – 2 bits; (default: 1);
- **ip** – IP address (Modbus TCP/IP);
- **port** – port (Modbus TCP/IP);
- **scan** – interval at which the check is performed (seconds);
- **timeout** – maximum response wait time (milliseconds)

Output/log configuration

XML element < OUTPUT ... />

- **name** – output/register name;
- **addr** – output/register address. Identifies the MODBUS address to write to according to the standard data addressing convention:
 - (0x) 000001..065536 Function 5/15: Write Single/Multiple Coils
 - (4x) 400001..465536 Function 6/16: Write Single/Multiple Registers
- **type** – data type:
 - Output Coils: 0 = Boolean (0/1)
 - Holding Registers: 1 = Signed (16-bit), 2 = Unsigned (16-bit), 3 = Swapped Long (32-bit), 4 = Long integer (32-bit), 5 = Swapped F.P. Little-endian (CDAB), 6 = Floating-Point Big-endian (ABCD)
- **expr** – value conversion expression (to be applied to the data to be written);
- **low** – lower limit of the data's valid range;
- **upp** – upper limit of the data's valid range (*upper limit*);
- **mode** – execution mode (0 = only when the value changes, 1 = always at every interval);

MODBUS Data Mapping Configuration

By configuring the **MODBUS data mapping**, the data logger operates as a **MODBUS slave** device, making its internal variables available via the **MODBUS RTU** protocol (over a serial line) and/or **MODBUS TCP/IP** (over an Ethernet or TCP/IP network).

Mapping allows you to define the correspondence between the data logger's internal locations (*tags*) and the MODBUS registers exposed to external devices. In this way, acquired or processed data can be made available to supervisory systems, PLCs, or other control devices.

The XML element <MODBUS-MAP ... /> defines the characteristics of the MODBUS map, specifying the following attributes:

- **name** – name of the map;
- **funct** – code of the MODBUS function served: 1 = Coil States (1x), 2 = Input States (2x), 3 = Holding Registers (4x), 4 = Input Registers (3x)
- **addr** – starting address of the data;
- **type** – data type: 0 = Boolean (0/1), 1 = Signed (16-bit), 2 = Unsigned (16-bit), 3 = Swapped Long (32-bit), 4 = Long integer (32-bit), 5 = Swapped F.P. Little-endian (CDAB), 6 = Floating-Point Big-endian (ABCD)
- **scan** – interval at which the map is updated (seconds);

3.3.8 Data logging

Data is recorded in an **SQLite database** within the device's **NAND Flash** memory.

Depending on the configuration, one or more separate databases (archive files) may be used. The archive files are located in the following folder:

```
/mnt/nandflash/da20k/arc
```

Each file is named according to the following format:

```
<n>.db
```

where:

- **<n>** represents the identification number assigned to the archive;
- **.db** indicates the extension of a database file.

Record Type

Each archive may contain one of the following record types:

- 0 - Historical record
- **1 - Instant data record** - Instant record (*)
- 2 - Alarm record

(*) Note: The database for an instant data archive is created in RAM (it is not stored on NAND Flash)

Record Format

The default standard format for data logging is the **Dynamic Record Format** described in section **3.3.10 – Record Format**.

Other recording formats may be implemented for specific applications.

Archive Management Mode

Data archives are managed by the data logger in a **circular mode**.

Once the maximum number of records (86,400) is reached, storage continues by progressively overwriting the oldest records.

The data retention time therefore depends on the configured recording interval. An indicative estimate of the retention time is shown in the table below.

Recording interval	Data retention
1 minute	~ 60 days
5 minutes	~ 10 months
15 minutes	~ 2 years
1 hour	~ 9 years

Example of an XML section related to data storage (STORAGES):

```

<STORAGES>
  <RECORD name="Snapshots" id="" type="1" format="0" scan="60" shift="0" file="1" >
    <WRITE name="TA ist" id="1" type="A" tag="0030" unit="°C" dec="1"/>
    <WRITE name="RH ist" id="2" type="A" tag="0032" unit="%" dec="0"/>
    <WRITE name="PLUV sum" id="3" type="A" tag="0108" unit="mm" dec="1"/>
  /RECORD>
  <RECORD name="Historical 5" id="" type="0" format="0" scan="300" shift="0" file="6" merge="1" backup="0" ...>
    <WRITE name="PLUV sum" id="3" type="B" tag="0108" unit="mm" dec="1"/>
  </RECORD>
  <RECORD name="Historical 30" id="" type="0" format="0" scan="1800" shift="0" file="6" merge="1" backup="0"
  ...>
    <WRITE name="TA avg" id="1" type="B" tag="0160" unit="°C" dec="1"/>
    <WRITE name="TA min" id="1" type="C" tag="0161" unit="°C" dec="1"/>
    <WRITE name="TA max" id="1" type="D" tag="0163" unit="°C" dec="1"/>
    <WRITE name="TA dev" id="1" type="F" tag="0166" unit="°C" dec="6"/>
    <WRITE name="RH med" id="2" type="B" tag="0174" unit="%" dec="0"/>
    <WRITE name="RH min" id="2" type="C" tag="0175" unit="%" dec="0"/>
    <WRITE name="RH max" id="2" type="D" tag="0177" unit="%" dec="0"/>
    <WRITE name="RH dev" id="2" type="F" tag="0180" unit="%" dec="6"/>
  </RECORD>
</STORAGES>
  
```

Record Storage Configuration

The XML element < RECORD ... /> includes the following attributes:

- **name** – record name;
- **id** – (optional) alternative storage identifier (if different from the general station ID);
- **type** – record type:
 0. **Historical record** (HISTORICAL data track)
 1. **Instant record** (INSTANT data record)
 2. **Alarm record** (ALARM data) ⁽¹⁾
- **format** – record format:
 0. **Standard Micros Dynamic Data** (Dynamic Record Layout)
 1. <reserved for future use>
 2. <reserved for future use>
 3. <reserved for future use>
 4. **XML MeteoContext** (specific to Kyrgyzstan control units)
- **scan** – interval in seconds at which the record is logged;
- **shift** – interval offset (to delay or advance the recording time (seconds));
- **file** – archive file number (example: specifying 1 will create the database file “1.db”);
- **merge** – option to merge records with the same time (not in use);
- **backup** – enables/disables backup copying of the record to external storage devices;
- **view** – enables/disables the display of historical data on the screen (not available);

⁽¹⁾ Alarms are logged for events not yet logged when the scan interval expires.

Data field configuration: <WRITE .../>

- **name** – data name;
- **id** – sensor identifier (measurement ID);
- **type** – data attribute⁽²⁾
- **tag** – data storage location;
- **unit** – unit of measurement for the data;
- **dec** – number of decimal places used to format the value;
- **hide** – hides the data from the display (not in use);

⁽²⁾ Letter identifying the type of statistical data:

- 'A' = Instantaneous value
- 'B' = Average value
- 'C' = Minimum value
- 'D' = Maximum value
- 'E' = Count
- 'F' = Standard deviation
- 'G' = Variance
- 'H' = Sum
- 'I' = Invalidation percentage
- 'L' = Minimum minute
- 'M' = Minute of the maximum
- 'R' = Error code
- 'J' = Diagnostic status

Hold memory configuration

This function creates a copy in RAM of the most recently stored data. This feature is useful for reducing response times to real-time data request commands (data cache).

XML example:

```
<RETAIN name="Memory retention" file="6" scan="1800" shift="0"/>
```

Configuration:

- **name** – function name;
- **file** – archive file number (to which retention applies);
- **scan** – interval in seconds corresponding to the data retention period;
- **shift** – interval offset to delay or advance storage (seconds);

3.3.9 Data backup

The data records stored in the archive files can also be configured to be **backed up** to external storage media, such as **SD memory cards** and/or **USB flash drives**.

In this case, the storage medium's memory will be managed in sequential mode, with progressive filling until the available space is exhausted.

The backup feature must be enabled in advance in the initialization file by selecting the storage device to be used.

The primary backup drive is the **SD Card**, mounted at the following default path:

```
/mnt/sd/backup/data
```

As an alternative or in addition to the SD card, you can also use a **USB flash** drive as a secondary drive, mounted at the following path:

```
/mnt/usb/backup/data
```

Backup Folder Structure

The backup folder path is automatically organized into **subfolders** that identify:

1. the data archive number
2. the year of recording

Example:

```
/mnt/sd/backup/data/6/2024
```

This path identifies the folder containing the backups of data archive no. 6 for the year 2024.

Backup file names

Data is copied into **daily files**, named according to the following format:

```
YYYYMMDD.dat
```

where:

- **YYYY** = year
- **MM** = month
- **DD** = day

Example:

```
20240101.dat  
20240102.dat  
20240103.dat
```

Replacing the storage medium

SD Memory Cards and USB Flash Drives can be **removed and replaced even while the data logger is running**.

To ensure compatibility between **Linux** and **Windows** operating systems, the devices must be formatted with **the FAT32 file system**.

3.3.10 Record trace

The data recorded in the data logger's archives is natively formatted according to the SIAP+MICROS standard known as **the Dynamic Record Format**.

The **Dynamic Record Format** contains information regarding the originating station (archive ID), the date/time of recording, and the type of data stored.

The date and time of recording constitute the record's timestamp, which always refers to the end of the processing period.

In *dynamically structured* record formats, the length of the record varies depending on the number and type of data contained. Therefore, in situations where the data to be included in the record is minimal, the length of the record itself—and consequently the space occupied by the data—will be minimal.

The dynamic record is suitable for containing current instantaneous data, statistical data obtained from processing functions, and alarm records.

The record consists of three distinct parts named respectively:

HEADER

BODY

TERMINATOR

Each of these parts is internally divided into fields separated by the character “,” (ASCII 44). All data managed by the system is recorded in the control unit's internal memory (NAND Flash) and, if a backup configuration is present, also on an external storage medium (SD Memory card).

Depending on the type of data, recording is performed in distinct memory areas. The division into areas is dictated, as described below, by specific storage requirements.

The data is stored in the corresponding memory area and is written as sequences of recognizable ASCII characters. The storage methods depend on the specific type of *data* in question. These methods are described by *the Record Layouts* that define their structure. Three different storage methods have been implemented, one for each type of *data*.

The record types are:

- **Statistical Data Record Format**
- **Instantaneous Data Record Format**
- **Alarm Data Record Layout**

For a detailed description of the SIAP+MICROS record layouts, refer to the **s011-d Dynamic Records** manual.

3.3.11 | Data Transmission

The data logger can be configured to transmit the following types of data via various communication modes and protocols:

- **Historical Data**
- **Alarms**
- **Images** (e.g., captured by a **webcam**)

The available transmission methods depend on the system configuration and the enabled communication interfaces (e.g., **cellular modem**, **radio-frequency modem**, **satellite transmitter**, etc.).

The settings related to data transmission are defined in the **<TRANSMISSIONS>** section of the configuration file, where you can specify the protocols used, the addresses of the destination servers, and the conditions for sending data.

This section describes the various supported transmission methods and their configuration parameters.

FTP Transmission

The data logger's main file transfer function is based on the following protocols:

- **FTP (File Transfer Protocol)**
- **SFTP (SSH File Transfer Protocol)**

The FTP function uses a dedicated background process that retrieves the files to be transferred from a local source folder. The files to be transmitted are prepared by extracting the data not yet sent from the archive and assigning them a name already formatted for the destination system.

To speed up and make the transfer process more reliable, each file has a predefined maximum size (*pack*).

Data files are prepared according to the configured scan interval. In the event of a communication interruption, the system automatically manages the recovery of unsent data by increasing the scan frequency (up to a maximum of 1 minute).

To transfer images from a webcam or other local files, you must specify the path of the source file to be sent. The function will then move and rename the file within the local structure before sending it.

To further reduce the size of the transmitted files, data compression can be enabled, provided that the destination system supports the corresponding decompression.

Local files are automatically deleted only after confirmation that the transfer has been completed.

Example of an XML configuration for FTP transmission:

```

<TRANSMISSIONS>
  <FTP name="Transfer" type="0" host="95.110.175.7" port="21" ssl="0" user="da22k" pass="*****" dir="" tag="...>
    <PUT name="Send Alarms" scan="60" shift="0" source="4.db" ... target="ST%iii_ALARM.. .dat." dir="/Data"/>
    <PUT name="Send historical data" scan="$14" shift="0" source="6.db" ... target="ST%iii_DATA... .dat"
dir="/..."/>
  </FTP>
</TRANSMISSIONS>
  
```

FTP Transmission Configuration

The XML element **< FTP ... />** includes the following attributes:

- **name** – transmission name;
- **type** – protocol: 0 = FTP (File Transfer Protocol), 1 = SFTP (SSH File Transfer Protocol)
- **host** – hostname or IP address of the server;
- **port** – server port (default: 21);
- **ssl** – data encryption: 0=None, 1=SSL/TLS if available, 2=Explicit SSL/TLS, 3=Implicit SSL;
- **user** – username (account);
- **pass** – login password (deprecated);
- **pwd** – encrypted login password;
- **dir** – remote directory (destination for upload or source for download);
- **tag** – variable tag location on output (transfer result);

File upload configuration:

Attributes of the XML element **<PUT .../>**

- **name** – upload name;
- **scan** – session interval used to prepare the copy of the file to be sent (seconds);
- **shift** – interval offset;
- **source** – number or name of the archive from which to retrieve data (e.g., 6.db) or path to a source file to be copied (e.g., mnt/nandflash/image/current.jpg);
- **pack** – maximum size of the data packet to be sent (default: 64 KB);
- **format** – transcoding / export of the record track:
 0. **Native** (no transcoding);
 1. **Normalized** (Dynamic Record Track with normalized date/time);
 2. **CSV Report (wide table)**;
 3. **CSV Export (long list)**;
 4. **XML (MeteoContext)**;
 8. **OTT MIS (ASCII)**;
- **header** – header rows for CSV Report (optional);
- **dfmt** – date and time format for CSV Report/Export (Default: ISO 8601 Standard);
- **delim** – delimiter for CSV Report/Export: 0=Europe, 1=EN/USA, 2=Tab;
- **sensor** – Sensor offset for CSV export (optional for SIRT encoding - CFR Tuscany);
- **period** – Export frequency: 0=None, 1=Hourly, 2=Daily, 3=Monthly;
- **cpr** – file compression (default: 0=No);
- **mode** – Write mode: 0=Overwrite (default), 1=Append;
- **target** – name of the remote destination file (*) ;
- **dir** – Remote destination directory (optional) if different from the one specified at the higher level;

File reception (download) configuration:

Attributes of the XML element **<GET .../>**

- **name** – download name;
- **scan** – session interval used to search for the file to download (seconds);
- **shift** – interval offset;
- **source** – name of the source file to download (e.g., cnf.xml);
- **target** – name of the local destination file (default: = source);

- **dir** – remote download directory (optional) if different from the one specified at the higher level;
- **action** – action to perform upon completion of the transfer: 0=None, 1=Restart software.

(*) The filename can be formatted using the following placeholder characters:

- %iii Station storage ID
- %yyyy%mm%dd Current year, month, and day
- %hh%nn%ss Current hour, minute, and second

Example:

```
ST%iii_DATE_%yyyy%mm%dd%hh%nn%ss.dat
```

GOES / METEOSAT Satellite Transmission

The data logger is capable of transmitting data via **GOES** or **METEOSAT** satellite systems, using a compatible transmitter connected to the device's serial port.

The system allows for the periodic transmission of **historical data (Timed Buffer)** or the immediate transmission of **alarm events (Random Buffer)**, according to the channels and modes assigned by the satellite operator.

For timed transmission, synchronization of the data logger's clock is essential, which is performed via the GPS receiver integrated into the transmitter.

Satellite Transmission Configuration

The XML element **< SATELLITE ... />** includes the following attributes:

- **name** – transmission name;
- **type** – satellite type:
 - 0 = GOES
 - 1 = METEOSAT
- **mode** – transmitter model used:
 - 1 = Microcom GTX-1.0
 - 2 = Microcom GTX-2.0
 - 3 = WaterLOG H-2221
- **com** – communication port to which the transmitter is connected:
 - 1 = COM1 RS-232
 - 4 = COM4 RS-232
- **baud** – serial communication speed (bps):
 - 1200, 2400, 4800, 9600, 19200, 38400, 57600, 115200 (default: 9600)
- **scan** – interval in seconds at which date/time synchronization with the GPS receiver is performed;
- **shift** – synchronization interval offset, used to advance or delay the clock update (default: -120 sec.);

Data or Alarm Transmission Configuration

The XML element **<SEND ... />** defines the parameters for transmitting data or alarms.

Available attributes:

- **name** – transmission name;
- **scan** – transmission interval (seconds);
- **shift** – transmission interval offset (seconds);
- **file** – number of the archive from which to retrieve data or alarms (example: 6.db or 4.db);
- **type** – transmission buffer type:
 - 0 = Timed Transmit Buffer (Historical Data)
 - 1 = Random Transmit Buffer (Alarms)
- **format** – data encoding format:
 - 0 = Native
 - 1 = Pseudo-binary (6-bit encoding)
- **fact** – Multiplication factor applied to values:
 - 0 = Automatic
 - 10, 100, 1000 = scaling factors
- **pack** – number of packets to retransmit to ensure historical data redundancy (0 = current packet only);

Iridium SBD Satellite Transmission

Iridium SBD (Short Burst Data) satellite transmission allows the data logger to send and receive short data messages via the **Iridium** satellite network using a compatible transceiver module.

The **SBD** system is designed for telemetry and remote monitoring applications where it is necessary to reliably transmit small amounts of data even in the absence of terrestrial network coverage. Data is sent in the form of **short binary packets**, which are routed through the Iridium satellite constellation to a data collection server.

Communication takes place via a **satellite relay session**, during which the data logger can:

- **transmit data or alarms** (to the collection center);
- **receive any incoming messages** (commands for the data logger).

Each SBD session establishes a temporary connection with the Iridium satellite network, enabling the exchange of messages between the device and the destination system.

Iridium Transceiver Session Configuration

The XML element **<IRIDIUM ... />** defines the parameters of the communication session.

The available attributes are:

- **name** – session name;
- **scan** – interval of the periodic retransmission session (seconds);
- **enab** – transmission activation condition:
 - 0 = Transmission disabled
 - 1 = Transmission enabled (default)
- **mode** – mode for receiving incoming messages:
 - 0 = Default: only if there are messages to send
 - 1 = Always: at every session
- **com** – communication port to which the transmitter is connected:

1 = COM1 RS-232

4 = COM4 RS-232

- **baud** – serial communication speed (bps):
1200, 2400, 4800, 9600, 19200, 38400, 57600, 115200 (default: 19200)

Data or alarm transmission configuration

The XML element **<SEND ... />** defines the parameters for transmitting data or alarms.

Available attributes:

- **name** – transmission name;
- **scan** – transmission interval (*) expressed in seconds;
- **shift** – transmission interval offset (seconds);
- **file** – number of the archive from which to retrieve data or alarms (example: 6.db or 4.db);
- **type** – record type:
 - 0 = Historical
 - 1 = Alarm
- **format** – data encoding format:
 - 0 = Native
 - 1 = Pseudo-binary (6-bit encoding)
- **fact** – Multiplication factor applied to values:
 - 0 = Automatic
 - 10, 100, 1000 = scaling factors
- **wait** – waiting time for retaining historical data before transmission is activated (seconds);

(*) The transmission interval for sending historical records must coincide with the data packet formation interval in accordance with the transcoding defined at the collection center. For alarms, however, it represents the scan interval used to check for the presence and transmission of a new alarm record.

3.3.12 Display

In this section, the user defines the list of measurements to be displayed (see section [3.2.4 – Current Measurements](#)). The display order corresponds to the order in which the items are entered in the configuration section.

The information displayed is updated at a scan interval, normally set to 3 seconds.

Example of XML configuration for display:

```
<DISPLAY scan="3">
  <ROW name="TA" text="Air temperature" tag="0030" unit="°C" dec="1"/>
  <ROW name="RH" text="Relative humidity" tag="0032" unit="%" dec="0"/>
  <ROW name="PLUV" text="Precipitation" tag="0108" unit="mm" dec="1"/>
  <ROW name="LIV" text="Water level" tag="0036" unit="m" dec="2"/>
  <ROW name="VBAT" text="Battery" tag="0048" unit="V" dec="1"/>
</DISPLAY>
```

Display Row Configuration

Each row displayed on the screen is defined using the XML element `<ROW ... />`, which includes the following attributes:

- **name** – element name;
- **text** – displayed text (label);
- **tag** – variable location (tag) of the data to be displayed.
- **unit** – associated unit of measurement.
- **dec** – number of decimal places (for value formatting).

3.3.13 Variables, e , and operators

The following tables list the variables and operators that can be used in configuration expressions.

Parameters and variables (tags)

\$id	Value of the parameter with ID (e.g., \$11 = value of parameter 11)
Mi	Value of the variable at memory location i (e.g., M1 = value of location 1) If the variable takes the value -9999, it indicates invalid data. Note: M0 indicates the raw data of the current measurement just acquired.
Vi	Validation status of memory variable i (e.g., V1 = validation status of variable M1). 1 = Valid data 0 = Invalid data.
Qi	Quality code of memory variable i (e.g., Q1 = quality code of variable M1). 1 = Valid data 3 = Acquisition error 4 = Value out of range 5 = Out of service or disabled

Arithmetic operators

+	Addition
-	Subtraction
/	Division
*	Multiplication
^	Exponentiation
MOD	Remainder of division

Logical operators

NOT	Logical negation (equivalent operator: !)
AND	Logical conjunction
OR	Logical disjunction

Comparison operators

=	Equal
>	Greater than
>=	Greater than or equal to
<	Less than
<=	Less than or equal to
<>	Not equal

Bitwise comparison operators

&	Bitwise AND
 	Bitwise inclusive OR

Boolean constants

FALSE	Equivalent to 0
OFF	
TRUE	Equivalent to the value 1
ON	

Mathematical functions

ABS	Absolute value of a number
ATN	Arctangent of a number
COS	Cosine of an angle
EXP	Exponent of the base of natural logarithms <i>and</i>
INT	Integer part of a number
LIM	Maximum or minimum value of a number between two limits
LN	Natural logarithm of a number
LOG	Common logarithm of a number
MAX	The maximum value between two numbers
MIN	Minimum value between two numbers
SGN	Sign of a number
SIN	Sine of an angle
SQR	Square root of a number
TAN	Tangent of an angle

3.4 Command interpretation

Via the Modbus RTU / TCP/IP input communication protocol, the data logger implements *User-Defined* Function No. 65, which allows for the transmission of a set of specific commands (*Siap+Micros* command set).

The function specification and the complete list of commands interpretable by the data logger are provided below.

3.4.1 Modbus protocol specification

User-Defined Modbus function code **65 (0x41) - SIAP+MICROS commands**

Request:

Field	Size	Value range
Slave ID	1 Byte	0x00 to 0xF7, 0xFF
Function code	1 Byte	0x41
Bytes count	2 bytes	0x0000 to 0xFFFF (<i>N</i>)
Data request	<i>N</i> Bytes	0x00 to 0xFF
CRC-16	2 Bytes	0x00 to 0xFF

Valid response:

Field	Size	Range value
Slave ID	1 Byte	0x00 to 0xF7, 0xFF
Function code	1 Byte	0x41
Bytes count	2 bytes	0x0000 to 0xFFFF (<i>N</i>)
Response data	<i>N</i> Bytes	0x00 to 0xFF
CRC-16	2 Bytes	0x00 to 0xFF

Error response:

Field	Size	Range value
Slave ID	1 Byte	0x00 to 0xF7, 0xFF
Error code	1 Byte	0xC1
Exception code	1 Byte	0x01, 0x02, 0x03, 0x04
CRC-16	2 Bytes	0x00 to 0xFF

The following paragraphs describe the command syntax.

Note:

If the commands are not sent correctly, the data logger will respond with:

- ?<*command name*> for unrecognized command
- 1 for incorrect parameters

3.4.2 General commands

Communication identifier <device-id>

Read command: **R IDSTAZ**
 Response: IDSTAZ <device-id>
 Write command^(*): **W IDSTAZ=<device-id>**
 Response: IDSTAZ <device-id>

Storage ID <storage-id>

Read command: **R ID_MEM**
 Response: ID_MEM <storage-id>
 Write command^(*): **W MEM_ID=<storage-id>**
 Response: ID_MEM <storage-id>

(*) Note: For the configuration commands to take effect, the data logger application must be restarted.

System Clock and RTC

The write command will set both the system clock and the RTC clock:

Read command: **CLK**
 Answer: <hh> <nn> <ss> <dd> <mm> <yyyy>
 Read command: **RTC**
 Response: <hh> <nn> <ss> <dd> <mm> <yyyy>
 Write command: **CLK <hh> <nn> <ss> <dd> <mm> <yy[yy]>**
 Response: <hh> <nn> <ss> <dd> <mm> <yyyy>

Firmware version (DA20K application)

Read command: **!FW**
 Response: DA20K ver. <x>.<y>.<z>

Reset data logger (software restart)

Command: **RESET MICROS**
 Response: RESET MICROS

Reboot data logger (hardware restart)

Command: **!TW**
 Response: Terminating Watchdog

3.4.3 , variable (), and parameter management

Variable locations (memory tags)

The read command requests the values of $\langle n \rangle$ locations starting from the starting address $\langle index \rangle$. The write command sets the values of $\langle n \rangle$ locations by specifying the index and value for each one.

Read command: **!IM $\langle n \rangle$ $\langle index \rangle$**
 Response: $\langle val1 \rangle$ $\langle val2 \rangle$... $\langle valn \rangle$

 Write command: **!WA $\langle n \rangle$ $\langle index1 \rangle$ $\langle val1 \rangle$ $\langle index2 \rangle$ $\langle val2 \rangle$... $\langle indexn \rangle$ $\langle valn \rangle$**
 Response: *no response*

User parameter (identifier: $\langle id \rangle$)

Read command: **!RP $\langle id \rangle$**
 Response: $\langle value \rangle$

 Write command: **!WP $\langle id \rangle$ $\langle value \rangle$**
 Response: $\langle value \rangle$

3.4.4 Archive management

Specify the archive number with: $\langle file \rangle$

Size (KB)

Command: **R_FILE $\langle file \rangle$**
 Response: **_FILE $\langle file \rangle$ $\langle size \rangle$**

Free space (KB)

Command: **!FR $\langle file \rangle$**
 Response: $\langle bytes free \rangle$

Used space (KB)

Command: **!MR $\langle file \rangle$**
 Response: $\langle bytes used \rangle$

Sequential Data Read (Read Data)

The command reads the data and temporarily moves the user's read pointer. Specify in the following order: archive number $\langle file \rangle$, user $\langle user \rangle$, number of packets to read $\langle pack \rangle$

Command: **!RD $\langle file \rangle$ $\langle user \rangle$ $\langle pack \rangle$**
 Response: $\langle data records \rangle$

Data Read Confirmation (*Read Set*)

The command aligns the read pointer with the temporary pointer. Specify: archive number *<file>*, user *<user>*

Command: **!RS *<file>* *<user>***
Response: *no response*

Data Read Restore

The command moves the read pointer immediately after the write pointer so that the entire file can be read again. Specify: archive number *<file>* and user *<user>*

Command: **!RE *<file>* *<user>***
Response: *no response*

Data Erasure (*Scratch*)

The command resets the write and read pointers so that the archive can be rewritten from the beginning:

Command: **!SC *<file>***
Response: *no response*

Point Reading (*)

Specify the year, month, day, hour, minute, and second of the record where the read pointer should be positioned. The response will contain the number of bytes to be read:

Command: **!PR *<file>* *<yyyy>* *<mm>* *<dd>* *<hh>* *<nn>* *<ss>***
Response: *<bytes to read>*

(*) Note: This command reposition the read pointer for all users.

Write data (*)

The command writes to the specified data archive (file no. 1–253):

Command: **!WR *<file>* *<data to write>***
Response: *No response*

(*) Obsolete command. Use the !WRB command instead

Writing data with a pointer

The command writes to the specified data archive (file no. 1–253) or to a system default file using a write start pointer. Normally used for writing the following system files: 0 = Configuration file (cnf.xml), 254 = Settings file (ini.xml), 255 = Application firmware (da20k):

Command: **!WRB *<file>* *<pointer>* *<data to write>***
Response: *No response*

Request latest data

The command returns the data from the most recent recording or from the most recent recordings within a preconfigured retention period (retention interval).

For example, with a retention interval preconfigured to 30 minutes, if a request is sent between 08:30 and 08:59, the response will contain records from 08:01 to 08:30 inclusive. If the same request is sent after 9:00 AM, the records received will cover the period from 8:31 AM to 9:00 AM inclusive. If the retention period is not configured, the response will contain only the most recent record.

The request message must specify the archive from which you want to read the data (*file*).

Syntax:

Command	!LTR !LBR !LKR !LXR <i>file [yyyy mm dd hh nn ss]</i>
Response	<Data Log> ⁽¹⁾

The command can also synchronize the data logger's clock if date and time settings are specified. The optional parameters are: *yyyy* (year), *mm* (month), *dd* (day), *hh* (hour), *nn* (minutes), and *ss* (seconds).

Note: Clock synchronization will only be performed if the current datalogger setting differs by between ± 3 sec. and ± 50 min.

Request historical data

This command can be used to request/retrieve data records recorded within a specific historical range. If available, all records prior to the requested time within the preconfigured retention period (including the record specified in the request) will be sent.

For example, with a retention interval set to 30 minutes, data up to 30 minutes prior will be returned. To retrieve data from 00:31 to 01:00, the request must be sent specifying 01:00:00.

If the retention period is not configured, the response will contain only the requested record.

In the request message, you must specify not only the archive from which you want to read the data (*file*), but also the date and time of the recording: *yyyy* (year), *mm* (month), *dd* (day), *hh* (hour), *nn* (minutes), and *ss* (seconds).

Syntax:

Command	!DTR !DBR !DKR !DXR <i>file yyyy mm dd hh nn ss</i>
Response	<Data trace> ⁽¹⁾

⁽¹⁾ The format of the data trace received in response depends on the type of command sent:

!LTR (<i>Last Text Records</i>)	<i>Standard dynamic format (ASCII)</i>
!DTR (<i>Data Text Records</i>)	
!LBR (<i>Last Binary Records</i>)	<i>Standard binary format</i>
!DBR (<i>Data Binary Records</i>)	
!LKR (<i>Last Compressed Binary Records</i>)	<i>Compressed binary track</i>
!DKR (<i>Data Compressed Binary Records</i>)	
!LXR (<i>Last eXtra Binary Records</i>)	<i>Compressed binary track with diagnostics</i>
!DXR (<i>Data eXtra Binary Records</i>)	

3.4.5 Output commands

Digital outputs O0–O3 (data logger)

Command: **!CO <n> <act1> <out1> <act2> <out2> ... <actn> <outn>**
Response: *no response*

Activation values <act>:

- 1: ON
- 2: OFF
- 3: PULSE (ON/OFF)
- 4: PULSE (OFF/ON)

Outputs <out>: 0 to 3

Example: **!CO 1 1 0** // Set output O0 to ON

Digital outputs DIG OUT OD1 to OD8, 12V (base board)

Command: **!OD<n> <act>**
Response: *OD<n> ON/OFF*

Activation values <act>:

- 0: OFF
- 1: ON

Outputs <n>: 0 to 8

Sample commands:

!OD1 ON // Turns on digital output OD1
!OD1 OFF // Turns off digital output OD1
!12V ON // Turns on the 12V-powered digital output ()
!12V OFF // Disables the 12V-powered digital output

Analog outputs CH10 OA1 and CH16 OA2 (base board)

Command: **!OA<n> <val>**
Response: *OA<n> <val>*

Setting values <val>: [millivolts]

Outputs <n>: 1 to 2

Example commands:

!OA1 1000 // Sets analog output OA1 to 1 V
!OA1 0 // Resets analog output OA1 to 0 V

4 Regulations

4.1 Safety Standards

A detailed examination of the design and manufacturing methods has made it possible to identify the risks the product may present throughout its entire life cycle, when used correctly, and thus define the essential requirements applicable to it. These requirements may be contained in one or more directives, and all must be met regardless of which directive they belong to. For a directive to apply to a product, two conditions must therefore be met:

- the product falls within its scope
- the product presents risks to which the essential requirements of the directive apply.

Based on the risk analysis conducted, described in the following pages, it has emerged that the European directives applicable to the product in question are the following:

European Directive	Title	Reference to the transposing law in Italy
2014/35/EU	Low Voltage Directive (LVD)	Legislative Decree No. 86 of May 19, 2016
2014/30/EU	Electromagnetic Compatibility (EMC) Directive	Legislative Decree No. 80 of May 18, 2016

The product in question falls within the scope of the Low Voltage Directive 2014/35/EU, transposed in Italy by Legislative Decree No. 86 of May 19, 2016, and the Electromagnetic Compatibility Directive 2014/30/EU, transposed in Italy by Legislative Decree No. 80 of May 18, 2016, both of which entered into force on May 26, 2016.

4.2 EMC

This equipment has been designed in accordance with the requirements of the directives indicated in the CE declaration attached to the product.

5 Environmental Conditions for Use

The equipment is designed for use in accordance with the specifications listed in the table below:

INTENDED USE AND LIMITS OF THE EQUIPMENT	AVAILABLE DATA / INFORMATION
Intended use	The intended use includes exclusively the measurement of physical and chemical parameters for meteorology, agrometeorology, hydrometry, environmental and climate monitoring, remote control and automation of water supply systems, wastewater treatment plants, sewer systems, etc., distributed logic control and automation systems, and specific applications for landslide monitoring, microbiological and chemical processes, etc.
Reasonably foreseeable improper uses and contraindications	Use in domestic, consumer, or hobbyist settings is improper; use by unqualified and/or inadequately trained persons is prohibited.
Environment of use	Use is not intended in environments where explosive, corrosive, or flammable gases or vapors are present.
Potential critical environmental factors	The environmental conditions for proper use are: <ul style="list-style-type: none"> - Reference temperature: 20 °C - Operating temperature: -40 to 80 °C - Maximum permissible relative humidity: 99% non-condensing - Storage temperature: 0 to 60 °C - Storage humidity: 80% maximum
Professional qualifications or experience required of operators	Personnel must be qualified or properly trained and aware of the risks involved.

NOTES

- Periodic updates are made to the information contained in this document. These are included in new editions of the document.
- The manufacturer may make modifications and/or changes to the product described in this document at any time and without prior notice.
- All rights reserved. Reproduction or duplication of this document, in whole or in part, is prohibited without the manufacturer's authorization.

6 Revision History

The following table lists the changes made to this document.

Version	Date	Updates
01	10/15/2024	Initial document.
02	12/02/2024	Acquisition of SDI-12 standard protocol sensors. Data backup to external storage devices.
03	03/26/2026	New graphical display interface. Local access management with users (optional). Sensor acquisition via Store & Forward protocol. Data acquisition via generic ASCII sensor. Anemometric processing with 360° prevailing wind sector. Rainfall processing with precipitation intensity. Reference evapotranspiration calculation (Penman-Monteith method). Modbus data mapping for Modbus Slave functionality. Data rate change control. Data and alarm storage in MeteoContext XML format (Kyrgyzstan). SFTP protocol integration (SSH File Transfer Protocol). FTP data export in CSV format (tabular report and/or long list). Data export to external media (SD Card or USB Flash drive). Data conversion to OTT-MIS file format (ASCII). Append write mode option for FTP(S) transfer. RC4-encrypted passwords for FTPS/SFTP access. GOES/METEOSAT satellite transmission. Iridium SBD (Short Burst Data) satellite transmission.

All information contained in this document is current as of the date of printing. Siap+Micros S.p.A. reserves the right to change the specifications without prior notice.

7 EU Declaration of Conformity

Dichiarazione di Conformità UE (DoC)

Fabbricante: SIAP+MICROS S.p.A.
Via del Lavoro, 1 – 31020 S. Fior (TV) – Italia
<https://www.siapmicros.com/>

La presente dichiarazione di conformità è rilasciata sotto la responsabilità esclusiva del fabbricante.

Oggetto della dichiarazione:

Descrizione	Codice Prodotto/Modello
Datalogger multifunzione con Linux	PEM-e022b-DA22KE

L'oggetto della dichiarazione di cui sopra è conforme alla pertinente normativa di armonizzazione dell'Unione:

- **2014/53/EU** Direttiva apparecchiature Radio (RED)
- **2011/65/EU** Restrizioni utilizzo di sostanze pericolose nelle apparecchiature elettroniche. (RoHSD)

Riferimento alle pertinenti norme armonizzate o riferimenti alle altre specifiche tecniche usate in relazione alle quali è dichiarata la conformità:

RED references:

ELECTROMAGNETIC COMPATIBILITY (Article 3.1b):

EN 61326-1 2021-06	Apparecchi elettrici per misura, controllo e uso da laboratorio – Prescrizioni EMC – Parte 1: Prescrizioni generali
EN 301 489-1 V2.2.3:2019	Compatibilità elettromagnetica e problematiche di spettro radio (ERM); Norma di compatibilità elettromagnetica (EMC) per apparecchiature e servizi radio; Parte 1: Requisiti tecnici comuni.
EN 301 489-52 V1.2.1:2021-11	Compatibilità elettromagnetica (EMC) Standard per apparecchiature radio e servizi; Parte 52: Condizioni specifiche per la comunicazione cellulare Radio e dispositivi mobili e portatili (UB); Standard armonizzato che copre i requisiti essenziali Dell'articolo 3.1, lettera b), della direttiva 2014/53 / UE

EFFECTIVE AND EFFICIENT USE OF RADIO SPECTRUM (Article 3.2):

EN 301 511 V12.5.1:2017-03	Sistemi globali per la comunicazione mobile (GSM); Apparecchiatura per stazioni mobili (MS); Norma armonizzata EN che soddisfa i requisiti essenziali in base all'articolo 3.2 della Direttiva 2014/53/EU
EN 301 908-1 V13.1.1:2019-11	Reti cellulari IMT; Norma armonizzata per l'accesso allo spettro radio; Parte 1: Introduzione e prescrizioni comuni
EN 301 908-2 V13.1.1:2020-06	Reti cellulari IMT; Standard armonizzato per l'accesso allo spettro radio; Parte 2: Apparecchiature utente (UE) CMDA Direct Spread (ULTRA FDD)
EN 301 908-13 V13.1.1:2019-11	Reti cellulari IMT; Standard armonizzato per l'accesso allo spettro radio; Parte 13: Apparecchiature utente (UE) per l'accesso radio terrestre universal evoluto (E-ULTRA)

HEALTH & SAFETY (Article 3.1a):

EN 61010-1 2010+A1:2021-11	Prescrizioni di sicurezza per apparecchi elettrici di misura, controllo e per l'utilizzo in laboratorio
EN 62311 2019	Valutazione degli apparecchi elettronici ed elettrici in relazione ai limiti di base per l'esposizione umana ai campi elettromagnetici (0 Hz to 300 GHz)

Riferimenti RoHSD:

EN 63000 2016+AMD1:2022	Documentazione tecnica per la valutazione di prodotti elettrici ed elettronici rispetto alla restrizione delle sostanze pericolose
-----------------------------------	--

Data
31-01-2023

Amministratore Delegato
Alex Stevanin

