

# e024 GigaSUM

## Linux Data Logger for Data Acquisition



User Manual  
Version 01

## Table of Contents

1	Introduction .....	5
1.1	Purpose and Target Audience of the Manual .....	5
1.2	Contact Information and Support .....	5
1.3	Symbols Used .....	5
2	Precautions and safety measures .....	7
2.1	Intended use .....	7
2.2	Warnings .....	7
2.3	Transport .....	8
2.4	Removing from Packaging .....	8
2.5	Wiring and Powering the Control Unit .....	8
2.6	During operation .....	9
2.7	Storage .....	9
2.8	Maintenance .....	9
2.9	Disposal .....	9
3	Description and Features of the Data Logger .....	10
3.1	Overview .....	10
3.2	Input power supply .....	12
3.3	Output Power .....	13
3.4	Analog and Digital I/O Acquisition Unit (Base Unit) .....	14
3.4.1	Pt100 Inputs .....	15
3.4.2	Analog Inputs .....	15
3.4.3	Digital Inputs .....	16
3.4.4	Analog Outputs .....	17
3.4.5	Digital outputs .....	17
3.4.6	Connectivity .....	17
3.5	Serial .....	17
3.6	Indicator LEDs .....	19
3.7	USB Ports .....	20
3.8	RJ45 Ethernet port .....	20
3.9	Micro-SD card connector .....	21
3.10	micro-SIM connector .....	21
3.11	Antenna connector .....	21
4	User Guide and Configuration Guide .....	22
4.1	Operating System .....	22
4.1.1	Startup .....	23
4.1.2	Remote connection .....	24
4.1.3	Network Configuration .....	25

4.1.4	Modem Configuration .....	26
4.1.5	Clock setting .....	28
4.2	Display interface .....	29
4.2.1	Home Screen .....	29
4.2.2	User Login .....	30
4.2.3	Station Information .....	31
4.2.4	Current Measurements .....	32
4.2.5	Data h .....	33
4.2.6	Data Logger Status .....	35
4.2.7	Service Functions .....	37
4.2.8	Paramet s .....	38
4.2.9	Configuration .....	39
4.2.10	Application firmware .....	41
4.2.11	Maintenance .....	43
4.2.12	Log .....	44
4.2.13	System .....	45
4.2.14	System Information .....	45
4.2.15	Date & Time .....	46
4.2.16	Network .....	47
4.2.17	Reboot .....	47
4.2.18	Device Power .....	48
4.3	Data logger configuration .....	49
4.3.1	tialization File .....	49
4.3.2	Configuration file .....	53
4.3.3	Main Cycle and Secondary Processes .....	54
4.3.4	User parameters .....	55
4.3.5	-measurement acquisition .....	56
4.3.6	Processing Functions .....	58
4.3.7	Control Section .....	62
4.3.8	Data logging .....	66
4.3.9	Data Backup .....	69
4.3.10	Record Format .....	70
4.3.11	I Data Transmission .....	71
4.3.12	Display .....	76
4.3.13	Variables, e , and operators .....	77
4.4	Command interpretation .....	79
4.4.1	Modbus Protocol Specification .....	79
4.4.2	General commands .....	80
4.4.3	, variable ( ), and parameter management .....	81

4.4.4	Archive Management .....	81
4.4.5	Output commands.....	83
5	Revision History .....	85

## 1 Introduction

---

This manual contains important information regarding the use and maintenance of the GigaSUM data logger. Always consult the manual before performing any operations on the instrument.

### 1.1 Purpose and Target Audience of the Manual

---

This manual provides:

- Safety information regarding the GigaSUM product
- Information on the device's hardware and connections
- Information on the installation, use, maintenance, and disposal of the device

This manual is primarily intended for technical personnel such as:

- Monitoring network designers
- Monitoring network operators
- Installers
- Technical operators
- Maintenance personnel

Keep this manual in a safe place and ensure a copy is always available to operators.

### 1.2 Contact Information and Support

---

For technical and sales information and support, please refer to the manufacturer's contact information.

#### **SIAP+MICROS S.p.a.**

Via del Lavoro 1,

31020 – San Fior (TV) - Italy

<https://www.siapmicros.com/>

<https://www.siapmicros.com/contatti/>

For details on technical specifications, please refer to the product page.

[https://www.siapmicros.com/acquisizione\\_dati/datalogger/](https://www.siapmicros.com/acquisizione_dati/datalogger/)

### 1.3 Symbols Used

---

Pay particular attention to the meaning of the following symbols, which may appear in this manual and in product documentation (labels, technical specifications, brochures, etc.).



General caution/danger symbol. Indicates a potential risk that may cause injury to persons or damage to property. Pay particular attention when this symbol is present.



Product disposal. This product must NOT be disposed of as municipal waste but rather in accordance with the European Directive on Waste Electrical and Electronic Equipment (WEEE) 2012/19/EU.



DC voltage and current symbol.

For the operator's safety, it is necessary to follow the procedures described in this manual and read all notes carefully.

## 2 Precautions and safety measures

---

### 2.1 Intended use

---

- Intended use: the intended use includes exclusively the acquisition, transmission, and processing of measurements of physical and chemical parameters for meteorology, agrometeorology, hydrometry, environmental and climate monitoring, remote control and automation of water supply systems, wastewater treatment plants, sewer systems, distributed logic control and automation systems, and specific applications for landslide monitoring, microbiological and chemical processes, etc. Use in domestic or hobbyist settings, as well as use by unqualified and/or inadequately trained persons, is prohibited.
- Environmental conditions for use:
  - Reference temperature 20°C.
  - Operating temperature range: -40 to +80 °C.
  -  Exercise extreme caution when operating at ambient temperatures exceeding 60°C. Use appropriate personal protective equipment when handling the device in such environments. The wiring used to power the instrument must be rated to operate at temperatures up to 92°C.
  - Maximum permissible relative humidity: 100% non-condensing.
  - Storage temperature: 0 to +60 °C.
  - Maximum storage humidity: 80%.
  - Maximum altitude 4000 m
  - Pollution degree 2
  - Overvoltage category II.
- The device is rated IPX0. The first characteristic digit indicates that the enclosure provides protection for persons against access to hazardous parts by preventing or limiting the entry into the enclosure of a part of the body or a tool held by a person, and at the same time the enclosure provides protection for the equipment against the entry of solid foreign objects. The second characteristic digit indicates the degree of protection provided by the enclosure against harmful effects on the equipment caused by the ingress of water into the enclosure. "X" indicates that there is no specific rating for protection against solid objects. "0" indicates no protection against water.

Installation: The acquisition system must be installed inside electrical enclosures made of steel or flame-retardant plastic with a flammability rating of V-0 or V-1 and accessible only to qualified personnel.

### 2.2 Warnings

---

The manufacturer declines all liability for malfunctions resulting from failure to follow instructions, tampering, uses not covered by this manual, improper use of the device, or use by untrained operators. Only authorized and trained personnel shall have access to the work area for normal operation and maintenance.

#### General Safety Rules

- Handle the instrument only with completely dry hands.
- The instrument must not be operated in the presence of flammable gases, fumes, or in any environment where there is a risk of explosion.
- Do not remove, replace, or modify any electrical or mechanical parts.

- Maintenance operations, component replacement, and work inside the device must be performed only by SIAP+MICROS specialized technical personnel or personnel trained by SIAP+MICROS.
- Pay attention to any warning labels regarding potentially hazardous procedures.

## **2.3 Transport**

---

To prevent damage to the equipment, handle with care during transport. Avoid impacts. Transport the GigaSUM in suitable protective packaging.

## **2.4 Removing from Packaging**

---

Before removing the packaging and installing the instrument, ensure that you have taken the following precautions:

- Use suitable gloves to protect against abrasions, etc.
- If any damage caused during transport by the supplier is found, return the instrument to the supplier.
- Once removed from the packaging, place the instrument and its components on a flat surface.
- Pay attention to the connectors on the side of the instrument case during this operation.

Before installing the instrument, verify that:

- The mains voltage at the installation site complies with the instrument's operating conditions.

## **2.5 Wiring and Powering the Control Unit**

---

The following procedure ensures proper power supply to the GigaSUM data logger using a lead-acid battery and a solar panel.

1. Connect the battery to the power connector at pins BATT 036 (+) and 037 (-).
2. Pay attention to the battery polarity: pin 036 must be connected to the positive terminal and pin 037 to the negative terminal.
3. Connect the solar panel to the power connector at pins PV 034 (+) and 035 (-).
4. Pay attention to the polarity of the solar panel: pin 034 must be connected to the positive terminal and pin 035 to the negative terminal.
5. As an alternative to the solar panel, you can connect an external power supply to pins VDC 038 (+) and 039 (-).
6. Turn on the device by setting the main switch to the ON position.

The power cables must have a minimum cross-section of  $1 \text{ mm}^2$  and a maximum of  $2.5 \text{ mm}^2$ . 10A fuses must be installed on the power lines connected to the BATT RECH and BATT inputs to ensure protection against fire hazards.

If external power supplies connected to the electrical power grid are used, pay particular attention to the selection of the power supply device, insulation, and mains filtering. The external power supply connected to the VDC input must be protected against short circuits. Furthermore, the output of this power supply must not exceed 60 VDC, and there must be double or reinforced insulation between the mains power supply and the output in accordance with EN 61010-1.

GigaSUM can also be powered by a non-rechargeable 12V nominal lithium battery that serves as a backup power supply. In this case, connect the lithium battery to the power connector at pins BATT 040 (+) and 041 (-), ensuring that pin 040 is positive and 041 is negative (for more details, see Chapter 3.2).

Correct power-up of the device is indicated by the status LED flashing (see Chapter3.6 ). During operation, avoid tampering with the electrical connections and completely disconnect the power supply before making any modifications.

## **2.6 During operation**

---

Avoid working on the electrical connections during operation: completely disconnect the power supply before performing any operation.

## **2.7 Storage**

---

If you do not plan to use the equipment for an extended period of time (at least one year):

- disconnect all cables from the device, place it in a clear plastic bag along with a packet of desiccant, and seal the bag with adhesive tape. Clearly label the bag with the contents and weight of the equipment, including the phrase “HANDLE WITH CARE.”
- Store the instrument in an environment with a temperature between 0°C and 60°C and humidity not exceeding 80%.
- Make sure the instrument is placed in a stable position and that it cannot be damaged or moved due to carelessness or distraction.
- Do not place other instruments or weights on top of it. Do not stack the instrument on top of other instruments, and in any case, ensure that the underlying support is solid and stable.

## **2.8 Maintenance**

---

Before cleaning the instrument, disconnect all connection cables. Use a soft, dry cloth for cleaning. Never use damp cloths, solvents, water, or other liquids. Compressed air may be used to remove any dust residue.

The product is equipped with protection against electrostatic discharge. Additionally, the power supplies are equipped with overcurrent protection fuses.

## **2.9 Disposal**

---

In accordance with European Union Directive 2012/19/EU on waste electrical and electronic equipment, this product must be disposed of by taking it to a designated collection point for the recycling of electrical and electronic equipment.

For more information on the nearest recycling center, contact your local authorities.

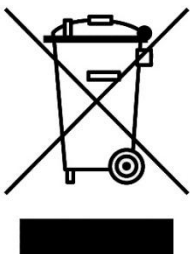

## **3 Description and Features of the Data Logger**

---

This chapter provides a general overview of the product. In particular, it explains how the data logger works, highlighting its main features, and describes the interface and individual connectors.

### **3.1 Overview**

---

The GigaSUM data logger is a data acquisition system based on the NXP i.MX6ULL Cortex™-A7 processor and the Linux operating system. The system consists of two units: the main processing unit on which the processor is mounted, and the analog and digital input/output acquisition unit (base unit).

As shown in Figure 3.1, the data logger features:

- 4 power inputs: solar panel, battery, external power supply, and auxiliary power supply.
- Analog and digital I/O acquisition unit.
- 9 serial communication ports: RS232, RS485, and SDI-12 interfaces.
- 2 USB connectors.
- RJ-45 Ethernet connector.
- MicroSD card slot.
- 4.3" resistive RGB touchscreen display with 480x272 24-bit resolution.
- Display on/off button.
- Power switch.
- Micro-SIM connector.
- Connector for the xG Modem antenna.
- Status LED.
- Integrated Sierra Wireless modem.
- 4GB eMMC internal memory.
- Internal temperature sensor.
- Internal RTC.
- Wi-Fi, Bluetooth, and BLE module.

Below is some information regarding the mechanical specifications of the box:

- Length: 182 mm
- Height: 62 mm
- Width: 236 mm
- Total weight: 875 g

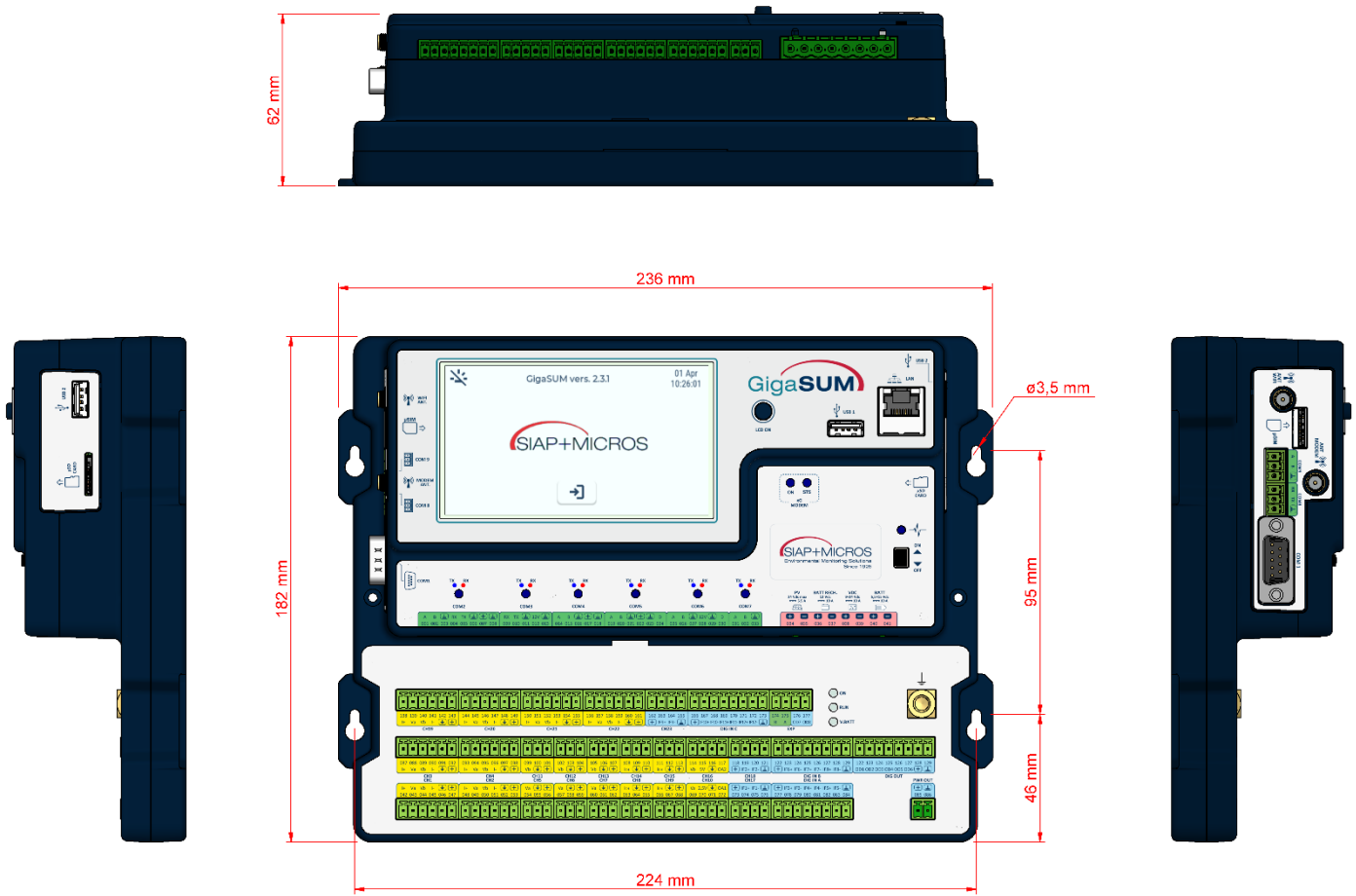

Figure3 .1 : front and side views of the data logger.

## 3.2 Input power supply

The data logger has 4 power inputs, as shown in Figure 3.2:

- 24V<sub>DC</sub> solar panel MAX  $\overline{\text{---}}$  5.5A: PV connector pins 034 (+) and 035 (-).
- 12V<sub>DC</sub> rechargeable lead-acid battery  $\overline{\text{---}}$  5A: BATT RECH. connector, pins 036 (+) and 037 (-).
- External power supply 9 – 24V<sub>DC</sub>  $\overline{\text{---}}$  5A: VDC connector, pins 038 (+) and 039 (-).
- 12V<sub>DC</sub> auxiliary power supply  $\overline{\text{---}}$  5A: BATT connector, pins 040 (+) and 041 (-).

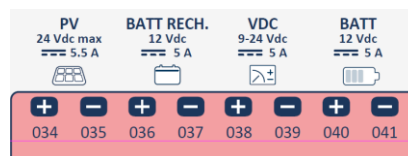

Figure 3.2 : power input terminal block.

The battery input is the datalogger's main power source and is equipped with:

- An electrostatic discharge protection circuit up to 15 kV with a peak power of 600 W (10/1000  $\mu$ s) and 4 kW (8/20  $\mu$ s).
- Fuse with a maximum current of 50A.

The solar panel input is designed to power the system and charge the lead-acid battery. Solar panels with a maximum voltage of 24 VDC and a maximum power of 100 W are supported. The data logger is equipped with an autonomous battery charger capable of recharging the lead-acid battery using the power absorbed by the solar panel. Under sunlight conditions, the battery charging circuit adjusts the solar panel's operating point to achieve maximum power and can deliver up to 5A to the battery. Dynamic tracking of the solar panel's optimal operating point to achieve maximum available power, known as MPPT (maximum power point tracking), is performed automatically by the internal circuitry.

The battery charger is also equipped with a control to protect the lead-acid battery from deep discharge. Specifically, if the battery voltage drops below 10.5V, the control completely shuts down the data logger to protect the battery from deep discharge. The battery charger remains operational; therefore, in the presence of solar radiation, it will resume charging the battery. When the battery voltage returns above 11.5V, the control will restore power to the system. The solar panel input is equipped with:

- An electrostatic discharge protection circuit up to 30 kV with a peak power of 1500 W (10/1000  $\mu$ s).
- Fuse with a maximum current of 40A.
- Filtering.

The external power supply can be used as an alternative to the solar panel as the system's primary power source, while the battery remains as a backup. The external power supply input is equipped with:

- An electrostatic discharge protection circuit up to 30 kV with a peak power of 1500 W (10/1000  $\mu$ s).
- Fuse with a maximum current of 40A.
- Filtering.

The auxiliary power supply can be provided by non-rechargeable lithium batteries and serves as the system's backup power source. The auxiliary input is equipped with:

- An electrostatic discharge protection circuit with a peak power of 600W (10/1000  $\mu$ s).
- Fuse with a maximum current of 50A.

The circuit features three diagnostic measurement points for voltage, current, and power, which are useful for verifying the system's power status:

- Solar panel input.
- Battery charger.
- Load.





**Note:**

Power from the solar panel (PV) and the external power supply (VDC) are not sufficient on their own to power on the data logger; they must always be accompanied by a rechargeable lead-acid battery (BATT RECH). The auxiliary power supply, on the other hand, is independent and is sufficient to power the data logger.

### 3.3 Output Power

---









The data logger has output power supplies on the serial terminals and on the base unit terminals. The following voltage outputs are available on the serial terminals:

- COM2, COM4, and COM5 serial terminals: controllable outputs with a voltage equal to the input supply voltage and a maximum current of 5A (pins  , and  ).
- COM3 and COM6 serial terminals: outputs driven by a regulated 12V voltage with a maximum current of 2A (pins  , and  ).

These voltage outputs are equipped with:

- An electrostatic discharge protection circuit up to 15 kV with a peak power of 600 W (10/1000  $\mu$ s) and 4 kW (8/20  $\mu$ s).
- Fuse with a maximum current of 40A (COM2, COM4, and COM5) and 100A (COM3 and COM6).

The following voltage outputs are available on the base unit terminals:

- PWR OUT terminal (pins 085 ( ) and 086 ( )): a constantly available voltage output equal to the input supply voltage, with a maximum current of 2.5A protected by a resettable fuse.
- DIG OUT terminal (pins 128 ( ) and 129 ( )): controllable output with a voltage equal to the input supply voltage and a maximum current of 2.5A (active by default), protected by a resettable fuse.
- Analog and digital input terminals of the base unit (pins marked with the symbols  -  and  -  ): voltage outputs equal to the input supply voltage and maximum current 200mA, protected by a resettable fuse.
- Terminal CH16: 5V supply voltage and maximum current of 200mA, protected by a resettable fuse.
- Terminal CH10: 2.5V reference voltage and maximum current of 10mA, protected by a resettable fuse.

All these voltage outputs are equipped with a 2-stage electrostatic discharge protection circuit compliant with IEC 61000-4-2 ESD protection: 30kV (air), 30kV (contact).

These output power supplies are useful for powering sensors connected via serial interface and external devices such as radios and transmitters.

The output voltages from the base unit, PWR OUT and DIG OUT, can deliver a total of 2.5A. The total current delivered by all voltage outputs, on the serial and base unit terminals, must not exceed 5A as indicated on the label.

### 3.4 Analog and Digital I/O Acquisition Unit (Base Unit)

The base unit is the primary source of data acquisition. This section provides a brief description of the connectors, while the following chapters cover the individual inputs and outputs in detail. The base unit features:

- **2.5V analog inputs:** 8 differential inputs  $\pm 2.5V$  that can alternatively be acquired with respect to ground as 16 single-ended inputs 0 – 2.5V. The same 8 differential inputs can be used for four-wire measurement of Pt100 thermistors.
- **10V analog inputs:** 8 ground-referenced 0–10V inputs that can alternatively be acquired as 4 differential  $\pm 10V$  inputs.
- **0–20 mA current inputs:** 4 current inputs 0–20 mA.
- **Digital inputs:** 8 opto-isolated inputs and 4 sinusoidal inputs.
- **Outputs:** 8 open-drain digital outputs, 2 analog outputs 0 – 2.5V.
- **RS485 COM port** with Modbus protocol.
- **Power supply outputs** with voltage equal to the supply voltage (described in Chapter 3.3).

Figure 3 at Figure 3.3 shows the terminal block of the base unit and Table 3.1 at Table 3.1 lists the pins with their respective descriptions.

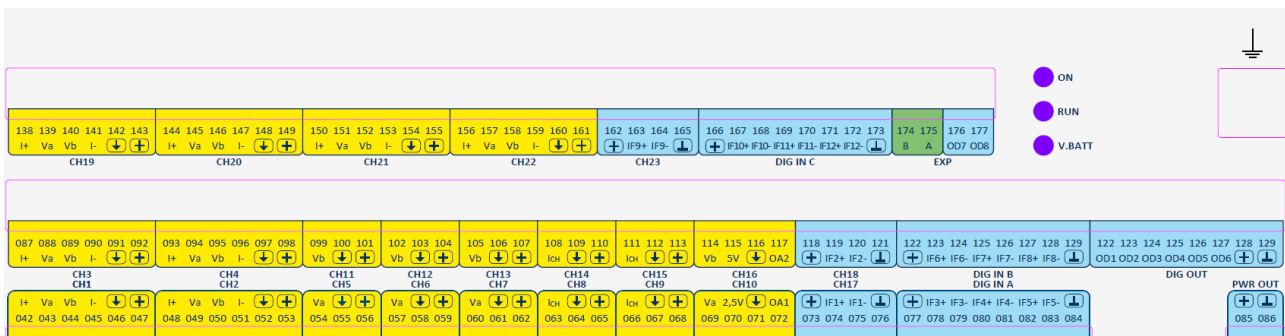

Figure 3.3 : terminal block of the analog and digital I/O acquisition unit.

PIN	DESCRIPTION
CH1, CH2, CH3, CH4, CH19, CH20, CH21, CH22: analog inputs with full scale $\pm 2.5V$	<ul style="list-style-type: none"> <li>• One differential input (<math>V_a - V_b</math>)</li> <li>• Two ground-referenced inputs (<math>V_a \downarrow</math>, <math>V_b \downarrow</math>)</li> <li>• One Pt100 input (<math>I+ - V_a - V_b - I-</math>)</li> <li>• 12V-200mA power supply output (<math>\uparrow</math> and <math>\downarrow</math>)</li> </ul>
CH5, CH6, CH7, CH11, CH12, CH13: analog inputs with full-scale range $\pm 10V$	<ul style="list-style-type: none"> <li>• One differential input on each pair of <math>V_a - V_b</math> connectors (CH5/CH11, CH6/CH12, CH7/CH13, CH10/CH16)</li> <li>• One ground-referenced input on a single connector (<math>V_a \downarrow</math>, <math>V_b \downarrow</math>)</li> <li>• 12V-200mA power supply output (<math>\uparrow</math> and <math>\downarrow</math>)</li> </ul>
CH10, CH16: analog inputs with $\pm 10V$ full scale and analog output	<ul style="list-style-type: none"> <li>• One differential input on the <math>V_a - V_b</math> connector pair (CH10/CH16)</li> <li>• One ground-referenced input on a single connector (<math>V_a \downarrow</math>, <math>V_b \downarrow</math>)</li> <li>• Reference voltage 2.5V-5mA (<math>\uparrow</math> and <math>\downarrow</math>)</li> </ul>









	<ul style="list-style-type: none"> <li>Power supply output 5V-200mA</li> <li>Analog output 0 – 2.5V (OA1 and OA2)</li> </ul>
CH8, CH9, CH14, CH15: 0 – 20mA current analog inputs and analog output	<ul style="list-style-type: none"> <li>One current input on a single connector (I<sub>CH</sub> )</li> <li>12V-200mA power output ( and )</li> </ul>
CH17, CH18, CH23, DIG IN A, DIG IN B, DIG IN C: IF1, IF2, IF3, IF4, IF5, IF6, IF9, IF10 opto-isolated digital inputs; IF7, IF8, IF11, IF12 sinusoidal digital inputs	<ul style="list-style-type: none"> <li>Frequency</li> <li>Counter</li> <li>Logic state</li> <li>12V-200mA power output (, and )</li> </ul>
DIG OUT: open-drain digital outputs and power output	<ul style="list-style-type: none"> <li>6 open-drain digital outputs</li> <li>12V-2.5A controllable power output (pin 128 () – pin 129 () )</li> </ul>
EXP: RS485 serial	<ul style="list-style-type: none"> <li>RS485 serial lines A and B</li> </ul>
EXP: open-drain digital outputs	<ul style="list-style-type: none"> <li>2 open-drain digital outputs</li> </ul>
PWR OUT: output power supplies	<ul style="list-style-type: none"> <li>12V-2.5A power output (pins 085 () and 086 () )</li> </ul>

Table3 .1 : connectors and pins of the base unit (analog inputs and outputs in yellow, digital inputs and outputs in blue, serial ports in green).

### 3.4.1 Pt100 Inputs

The base unit is equipped with eight analog inputs with Pt100 acquisition functionality on connectors CH1, CH2, CH3, and CH4, CH19, CH20, CH21, and CH22<sup>1</sup>. The resistance value is measured using the four-wire technique and involves the I+ (excitation current source), I- (excitation current return), Va, and Vb terminals (measurement of the voltage across the resistor). The resistor must be connected with one end to I+ and Va and the other end to I- and Vb. Specifically, at each acquisition cycle, a pulse current (<sup>2</sup>) is generated at the I+ terminal; as this current flows through the thermoresistor, it creates a potential drop measured between the Va and Vb inputs. The current returns to I- and generates a reference for the ratiometric measurement of the potential drop across the thermoresistor.

The Pt100 inputs have a resolution of 24 bits and are equipped with:

- An electrostatic discharge (ESD) protection circuit compliant with IEC 61000-4-2: 30 kV (air), 30 kV (contact), on both the measurement inputs and the current return path for reference generation.
- Differential low-pass filtering with a cutoff frequency of approximately 750 Hz.

### 3.4.2 Analog Inputs

The base unit is equipped with 8 24-bit differential analog inputs with a full-scale voltage of ±2.5V and an additional 8 24-bit analog inputs with a full-scale voltage of ±10V.

The voltage inputs are identified as Va and Vb and can be acquired either individually, with reference to ground, or in pairs in a differential configuration (Va as positive and Vb as negative). The voltage measurement is provided in µV.

A low-power 12V power output (200mA) is also available on the same connectors. In addition, terminal CH16 provides a 5V output (200mA), while terminal CH10 provides a 2.5V voltage reference. These output voltages

<sup>1</sup> Pt100 sensors are acquired on differential channels; therefore, each Pt100 sensor added reduces the total number of available differential channels by one.

<sup>2</sup> Enable this only for the measurement cycle to avoid altering the thermal conditions of the Pt100 due to the Joule effect.

are useful, for example, for measuring signals from potentiometer sensors, such as those used for wind direction detection.

Four analog inputs are configured for acquiring current signals in the 0–20 mA range, without the need for external precision resistors. The channels designed for this functionality are CH8, CH9, CH14, and CH15, which provide current measurements directly in  $\mu\text{A}$ .

All inputs are equipped with an electrostatic discharge (ESD) protection circuit compliant with IEC 61000-4-2: 30 kV (air), 30 kV (contact).

Inputs with a 2.5V full-scale range feature:

- Differential low-pass filtering with a cutoff frequency of approximately 750 Hz.
- Ground-referenced low-pass filtering with a cutoff frequency of approximately 15.9 kHz.

Inputs with a full-scale range of 10V feature:

- Differential and ground-referenced low-pass filtering with a cutoff frequency of approximately 188 kHz.

The current inputs feature:

- Ground-referenced low-pass filtering with a cutoff frequency of approximately 1.8 MHz.

### **3.4.3 Digital Inputs**

---

The base unit is equipped with 8 opto-isolated digital inputs. Each input consists of a pair of IF+ and IF– pins (for example, IF1+ and IF1– for digital input 1 on connector CH17). The input specifications are:

- 5 kV<sub>RMS</sub> isolation between IF+ and IF–.
- Internal termination resistance of 10 k $\Omega$ .
- Acquisition: frequency (0.5 – 5000 Hz), counter ( $0 - (2^{32} - 1)$ ), and digital state (0, 1).

This type of input allows for the acquisition of both square-wave signals and dry contacts. In the first case, IF– must be connected to ground and IF+ to the signal's positive terminal. In the case of dry contacts, it is necessary to apply a supply voltage to IF+ to bias the phototransistor and connect the contact between IF– and ground. For this purpose, a 12 V power supply is available on the connectors.

For example, to connect a dry contact to CH17, a jumper must be placed between the 12 V terminal and the IF1+ terminal, while the contact must be connected between IF1– and ground. When the contact is open, no current flows through the photodiode, and the signal is read by the data logger as a high logic state, thanks to the internal pull-ups. When the contact closes to ground, current flows through the photodiode and the signal is read as a low logic state.

There are also 4 comparator inputs available for acquiring AC sensors, such as variable reluctance sensors used in some wind speed measurements.

These inputs incorporate a differential comparator that, starting from a sinusoidal input signal, generates a square wave of the same frequency, which is used for data acquisition. This feature allows the use of passive sensors with a sinusoidal output. As with the opto-isolated inputs, these inputs can also be used for frequency measurements, counting, or logic-level detection.

The digital inputs are distributed among the connectors as follows:

- Connector CH17: IF1 opto-isolated digital input.
- Connector CH18: IF2 optically isolated digital input.
- DIG IN A connector: IF3, IF4, and IF5 optically isolated digital inputs.
- DIG IN B connector: IF6 optically isolated digital input, IF7 and IF8 differential comparator inputs.

- Connector CH23: IF9 opto-isolated digital input.
- DIG IN C connector: IF10 opto-isolated digital input, IF11 and IF12 differential comparator inputs.

The comparator inputs are equipped with an electrostatic discharge protection circuit compliant with IEC 61000-4-2 ESD protection: 30 kV (air), 30 kV (contact).

### **3.4.4 Analog Outputs**

---

The base unit features 2 12-bit 0–2.5V analog outputs on pins OA1 (CH10 connector) and OA2 (CH16 connector).

### **3.4.5 Digital outputs**

---

The base unit features 8 open-drain digital outputs, 6 on the DIG OUT connector and 2 on the EXP connector. Each digital output has the following characteristics:

- Open-drain type with a 1Ω – 2W limiting resistor
- Maximum current 500mA.
- Maximum voltage 24V.
- Electrostatic discharge (ESD) protection circuit compliant with IEC 61000-4-2: 30 kV (air), 30 kV (contact).

### **3.4.6 Connectivity**

---

An RS485 serial interface configured at 57600 bps, 8 data bits, no parity check, and 1 stop bit is available on the EXP connector. This serial interface allows direct acquisition of measurements from the analog and digital inputs and outputs.

## **3.5 Serial**

---

The data logger has 9 serial ports:

- COM1: RS232 interface with DB9 connector.
- COM2: RS232 and RS485 interface.
- COM3: RS232 interface.
- COM4: RS485 interface.
- COM5: RS485 and SDI-12 interface.
- COM6: RS485 and SDI-12 interface.
- COM7: RS485 interface.
- COM8: RS232 interface.
- COM9: RS485 interface.

In addition, 5 serial ports have a power output available on their respective connectors, specifically:

- COM2, COM4, and COM5: voltage equal to the input supply voltage and maximum current of 5A.
- COM3 and COM6: voltage regulated to 12V and maximum current 2A.

The serial ports are not all configurable in the same way; in particular, they differ in the setting of the number of data bits and the number of stop bits. The3 Table.2 summarizes the configuration differences of the various serial ports.

SERIAL	NUMBER OF DATA BITS	NUMBER OF STOP BITS	PARITY
COM1	5, 6, 7, 8	1, 1.5, 2	None, even, odd
COM2	5, 6, 7, 8	1, 1.5, 2	None, even, odd
COM3	5, 6, 7, 8	1, 1.5, 2	None, even, odd
COM4	5, 6, 7, 8	1, 1.5, 2	None, even, odd
COM5	7, 8	1, 2	None, even, odd
COM6	7, 8	1, 2	None, even, odd
COM7	7, 8	1, 2	None, even, odd
COM8	5, 6, 7, 8	1, 1.5, 2	None, even, odd
COM9	7, 8	1, 2	None, even, odd

3 Table.2 : data logger serial configuration settings.

The RS485 interfaces are equipped with a protection circuit against electrostatic discharges up to 20kV with a peak power of 500W (8/20µs), while the SDI-12 interfaces have a protection circuit against electrostatic discharges up to 30kV with a peak power of 4kW (8/20µs).

The serial connectors are described in detail at 3 Table.3 .

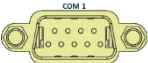
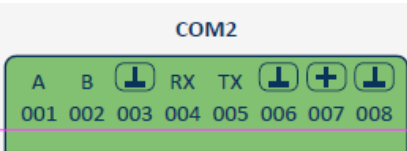
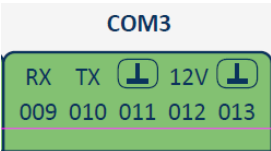
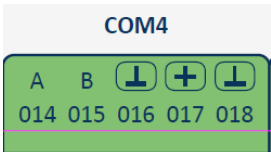
CONNECTOR	DESCRIPTION
	DB9 connector
	Pin 1: RS485 A Pin 2: RS485 B Pin 3: Ground Pin 4: RS232 Rx Pin 5: RS232 Tx Pin 6: Ground Pin 7: 12V (max 5A) Pin 8: Ground
	Pin 9: RS232 Rx Pin 10: RS232 Tx Pin 11: Ground Pin 12: 12V (max 2A) Pin 13: Ground
	Pin 14: RS485 A Pin 15: RS485 B Pin 16: Ground Pin 17: 12V (max 5A) Pin 18: Ground

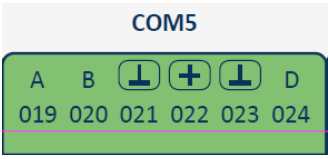
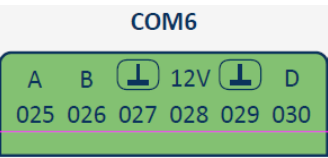
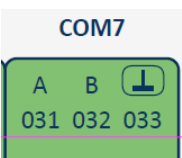
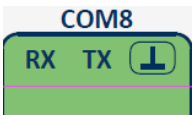
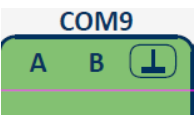
	<p>Pin 19: RS485 A                  Pin 20: RS485 B                  Pin 21: Ground                  Pin 22: 12V (max 5A)                  Pin 23: Ground                  Pin 24: SDI-12 data line</p>
	<p>Pin 25: RS485 A                  Pin 26: RS485 B                  Pin 27: Ground                  Pin 28: 12V (max 2A)                  Pin 29: Ground                  Pin 30: SDI-12 data line</p>
	<p>Pin 31: RS485 A                  Pin 32: RS485 B                  Pin 33: Ground</p>
	<p>RS232 Rx                  RS232 Tx                  Ground</p>
	<p>RS485 A                  RS485 B                  Ground</p>

3 Table.3 : description of serial connectors.

### 3.6 Indicator LEDs

The data logger is equipped with the following indicator LEDs:

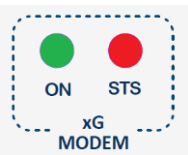
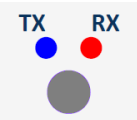
LED	DESCRIPTION
	<p>Status LED: indicates the operational status of the data logger.</p>
	<p>Modem power and operation LEDs: the ON LED indicates that power is supplied to the modem, while the STS LED indicates the modem's operational status (lit during communication).</p>
	<p>Serial port operation LEDs: The COM2, COM3, COM4, COM5, COM6, and COM7 serial ports are equipped with an LED indicating their operational status (blue when transmitting, red when receiving).</p>

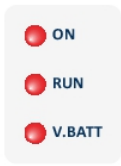
	<p>Base unit status LED:</p> <ul style="list-style-type: none"> <li>• ON flashes with each measurement cycle</li> <li>• RUN indicates the status of the internal watchdog</li> <li>• VBATT indicates the battery charge status (1 flash indicates that the battery is low, 5 flashes indicate that the battery is fully charged)</li> </ul>
---	---

3 Table.4 : description of the indicator LEDs.

### 3.7 USB Ports

Type A USB connectors are located on the front panel (USB 1) and on the side panel (USB 2).

The USB1 port can be used to insert USB flash drives for data backup or for the following service operations:

- Downloading data or logs;
- Updating configuration files;
- Application firmware updates;



Figure3 .4 : front (USB 1) and side (USB 2) USB connectors.

### 3.8 RJ45 Ethernet port

The RJ45 Ethernet connector is located on the front panel (Figure3 .5 5) and is internally connected to a 10/100 Mbps Base-T/TX Ethernet switch.

The Ethernet port allows the data logger to be connected to a network with various devices (e.g., PC, WebCam, Router, Switch, PLC, etc.).



Figure3 .5 : RJ45 Ethernet connector.

### 3.9 Micro-SD card connector

---

The push-push type connector for the microSD card is located on the right side of the data logger (Figure3 . 6). The label on the side panel of the case indicates the direction in which the SD card should be inserted.

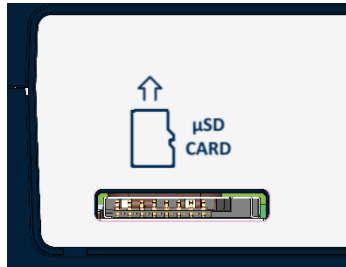

Figure3 . 6: microSD card connector.

### 3.10 micro-SIM connector

---

The push-pull connector for micro-SIM cards is located on the left side of the data logger (Figure 3.7). The SIM card must be inserted as shown on the label on the front panel of the box.

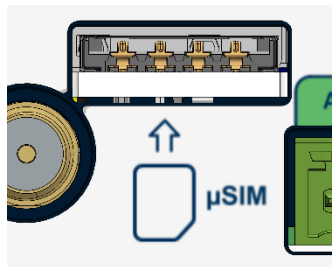

Figure3 . 7: micro-SIM connector.

### 3.11 Antenna connector

---

The RF connector for the GSM antenna is located on the left side of the data logger (Figure3 . 8).



Figure3 . 8: RF connector for GSM antenna.

## 4 User Guide and Configuration Guide

---

This chapter provides a comprehensive overview of the configuration and use of **the GigaSUM data logger**. In particular, it describes the operating system architecture and the features of the integrated management software (application firmware).

The application implements the main functions of a data logger, including data acquisition from measurement sensors, data processing and recording, as well as data transmission via available communication devices.

### 4.1 Operating System

---

**GigaSUM** is a device based on an **Embedded Linux** system, built using **Yocto Project 4.0 LTS** (Kirkstone), the NXP i.MX release 5.15 distribution, and Linux kernel version 5.15.52.



The operating system is preloaded on the following storage medium:

- **4GB eMMC (embedded MultiMediaCard)**  
Internal industrial-grade NAND Flash storage (usable capacity: ~3.7 GiB)

The management application and data archives are also stored on the eMMC at the following base path:

- **/home/da20k**

List of folders and files required for the datalogger to function properly:

- **arc** Data archive folder (.db)
- **log** Log file folder (.log)
- **ftp** Temporary folder for FTP transfer (if configured).
- **ini.xml** Data logger initialization file.
- **cnf.xml** Data logger configuration file.
- **from 20k** Data logger management application (firmware).
- **start.sh** Application startup shell script.
- **SerMux** Serial management driver (COM2–COM7).
- **appsettings.json** SerMux driver configuration file.
- **backlight.sh** Display management shell script.
- **modem.sh** Modem management shell script.

### 4.1.1 Startup

---

The data logger management application (**20k** firmware) starts automatically after the operating system has finished loading, via a link to the **start.sh** shell script.

Upon first startup, the system automatically creates the subfolders necessary for proper operation. Any additional processes required by the data logger are also started automatically during the boot phase.



*Booting Embedded Linux*

Upon power-up, wait approximately 1 minute for the operating system to finish booting and the application to load. At the end of this phase, the display will show the initial screen.



*Initial graphical screen*

For instructions on using the graphical interface, refer to section [4.2 – Display Interface](#).

## 4.1.2 Remote connection

You can connect to the system via the **LAN** network card using **SSH (Secure Shell)** access by connecting to the following host: [root@192.168.1.5](ssh://root@192.168.1.5)

Terminal command:

```
ssh root@192.168.1.5
```

For more advanced control over system settings, it is recommended to use software that allows remote connection via the **SSH** or **SFTP** protocol, providing a graphical interface for file browsing and management.

One example is **WinSCP**, a graphical SFTP client for Microsoft Windows systems, which allows you to explore the remote device's file system and securely transfer files using the SSH protocol.

To connect to the GigaSUM data logger:

1. Open WinSCP.
2. Create the remote site to connect to by entering the following information:
  - **Protocol:** SFTP
  - **Server:** 192.168.1.5
  - **Port:** 22
  - **Username:** root
  - **Password:** \*\*\*\*\*
3. Click **"Log In"** to connect and browse the device's contents.

Example of viewing the application folder with WinSCP:

/home/da20k/				
Nome	Dimensione	Modificato	Diritti	Proprietario
		17/03/2026 15:02:51	rw-r--r--	root
log		08/04/2026 00:18:38	rw-r--r--	root
arc		17/03/2026 15:05:20	rw-r--r--	root
cnf.xml	9 KB	30/03/2026 11:17:37	rw-r--r--	root
ini.xml	1 KB	27/03/2026 18:22:20	rw-r--r--	root
start.sh	3 KB	25/02/2026 17:00:00	rw-r--r--	root
da20k	2 068 KB	26/01/2026 11:00:00	rw-r--r--	root
backlight.sh	6 KB	02/12/2025 13:00:00	rw-r--r--	root
SerMux	128 KB	10/07/2025 10:25:14	rw-r--r--	root
shell_cmdline	45 KB	27/03/2025 11:34:44	rw-r--r--	root
modem.sh	8 KB	20/03/2025 11:00:00	rw-r--r--	root
appsettings.json	2 KB	27/01/2025 09:00:00	rw-r--r--	root

Note: The device's SSH server is configured to listen exclusively on the local address 192.168.x.y. Any changes to the SSH service settings can be made by editing the configuration file located at the following path: `/etc/ssh/sshd_config`

### 4.1.3 Network Configuration

---

The network interface (**eth0**) configuration is defined by the 10-eth0.network file, used by the *systemd* service in the path: /etc/systemd/network

By default, the **eth0** interface is configured with a default **static IP** address of: **192.168.1.5**

10-eth0.network

```
[Match]
Name=eth0

[Network]
Address=192.168.1.5/24
Gateway=192.168.1.1
DNS=8.8.8.8
```

Network configuration details:

- **Name=eth0**: specifies the name of the interface to be configured;
- **Address=192.168.1.5/24**: sets the interface's static IPv4 address and the CIDR prefix (equivalent to the network mask 255.255.255.0);
- **Gateway=192.168.1.1**: sets the default gateway (used to route traffic to external networks);
- **DNS=8.8.8.8**: specifies the DNS servers used for domain name resolution (in this case, Google's public DNS server is used);

If you want the IP address to be assigned dynamically via **DHCP**, use the following configuration:

10-eth0.network

```
[Match]
Name=eth0

[Network]
DHCP=yes
```

Note: You can easily configure the network card using the graphical user interface. For this, refer to section [4.2.16 – Network](#).

## 4.1.4 Modem Configuration

---

Modem configuration allows you to establish an Internet connection using a **3G/4G** mobile network module.

The GigaSUM data logger has an integrated modem connected internally to the ttyUSB2 port. The default settings for the modem serial port are as follows:

- **Baud Rate:** 115200 bps
- **Data Bits:** 8
- **Parity:** None
- **Stop Bits:** 1

To establish an Internet connection, the system uses the **PPP (Point-to-Point Protocol)** to create a virtual network interface named **ppp0**.

The PPP connection configuration files are described below.

### PPP Configuration (Internet)

PPP uses the configuration file located at: `/etc/ppp/peers/internet`

```
# /etc/ppp/peers/internet

# General settings
debug          # Enable debugging for detailed logs

# Modem parameters
/dev/ttyUSB2  # Serial device where the modem is connected
115200        # Serial port speed (baud rate)

# PPP connection parameters
noauth        # Do not require local authentication
defaultroute  # Set the default route
usepeerdns    # Use the provider's DNS
connect "/usr/sbin/chat -v -f /etc/chatscripts/dialup -T *99***1#"

```

CHAT connection script

### Connection script (CHAT)

The PPP configuration calls a **CHAT** script to initiate the connection with the modem. The phone number for anonymous connection is passed via the **-T \*99\*\*\*1#** parameter

The script file is located at: /etc/chatscripts/dialup

```
# /etc/chatscripts/dialup

ABORT      "BUSY"
ABORT      "NO CARRIER"
ABORT      "NO ANSWER"
ABORT      "ERROR"
TIMEOUT    12
""         ATV1
OK         ATE0
OK         ATH
OK         \d\dATD\T
TIMEOUT    22
CONNECT    \c
```

### PPP Connection Test

To manually activate the PPP connection, run the following command:

```
$ pon internet
```

You can verify that the PPP interface has been activated with the command:

```
$ ifconfig ppp0
```

If the connection is active, a **ppp0** network interface with an assigned IP address will be displayed:

```
ppp0: flags=4305<UP,POINTOPOINT,RUNNING,NOARP,MULTICAST> mtu 1500
    inet 10.13.129.225 netmask 255.255.255.255 destination 10.64.64.64
    ppp txqueuelen 3 (Point-to-Point Protocol)
    RX packets 13 bytes 702 (702.0 B)
    RX errors 0 dropped 0 overruns 0 frame 0
    TX packets 23 bytes 626 (626.0 B)
    TX errors 0 dropped 0 overruns 0 carrier 0 collisions 0
```

## 4.1.5 Clock setting

To ensure an accurate time reference, the data logger is equipped with a built-in hardware **RTC**. The **RTC (Real-Time Clock)** is used to periodically synchronize the operating system's internal clock.

Upon first power-up, both the system clock and the RTC clock may not be set correctly. You can set them via a connection to the system as follows:

### Setting the system clock

For example, suppose you want to set the date to April 1, 2026, at 12:30 PM. Use the 'date' command as follows:

```
$ date -s "2026-04-01 12:30:00"
```

### Synchronizing the hardware clock (RTC)

After setting the system clock, you can also synchronize the hardware clock (RTC) with the following command:

```
$ hwclock --systohc
```

Note: The above setup and synchronization procedure can be simplified by using the display interface (see section [4.2.15 – Date & Time](#)) or by using the DAK application software as described below.

### Clock setup and synchronization via the DAK application

- 1) Select: *Run – Synchronize Clock*
- 2) Set the date.
- 3) Set the time (or select: *Synchronize with PC clock*).
- 4) Press *Enter* and confirm the operation.

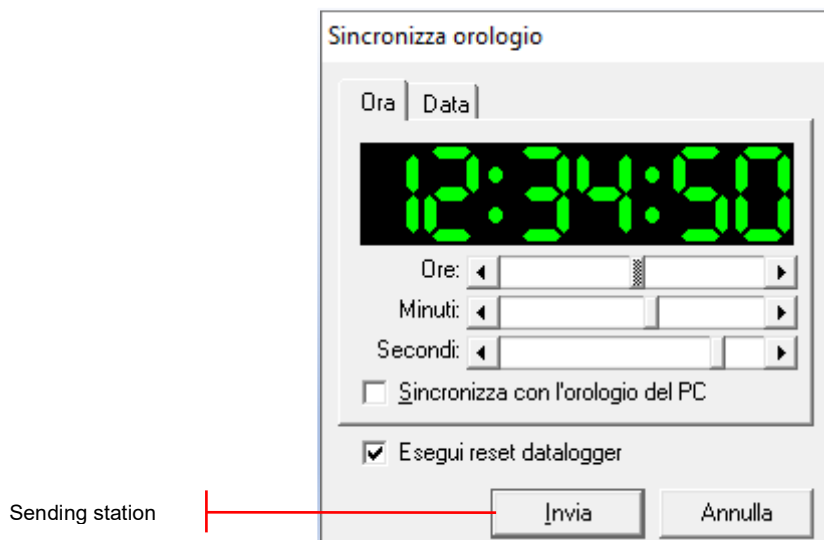

## 4.2 Display interface

---

The GigaSUM data logger is equipped with a **touchscreen** display that allows the user to view the acquired data and configure the system. Various graphical pages are available that display, depending on the loaded configuration, the acquired measurements and the status of the control unit.

Interaction is via touch on the screen:

- press the icon button to select the corresponding page;
- Swipe your finger to scroll through a list or table in the desired direction;

The display backlight is normally off to reduce power consumption; the display can be reactivated by touching the screen or pressing the front button (LCD ON).

After 10 minutes of inactivity, the display turns off automatically. Alternatively, the display can be turned off immediately by pressing the **Display Off** icon 

### 4.2.1 Home Screen

---

The home screen displays the **Login** button,  which the user can use to access the data logger:



*GigaSUM Display – Home Screen*

## 4.2.2 User Login

If the data logger has been previously configured for user management, the subsequent login screen will prompt you to enter your login credentials (username and password). Otherwise, access will be anonymous, and the display will proceed directly to the main screen.

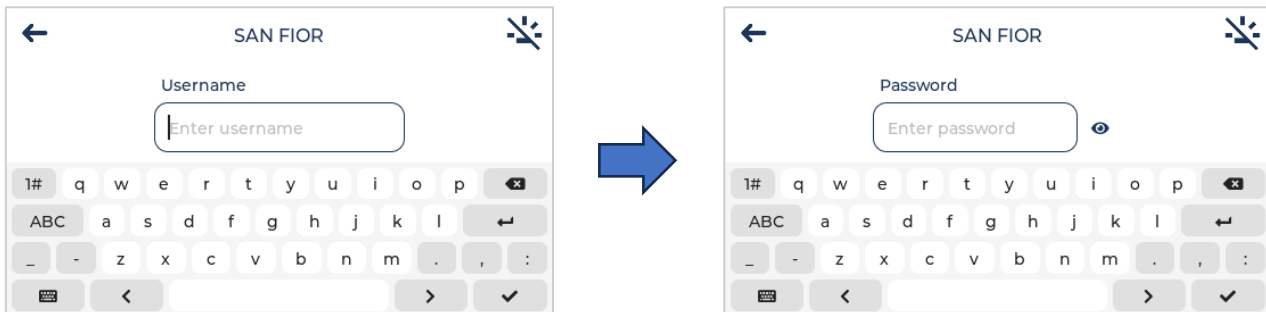

*Login Screens – Username and Password Request*

Logging in with a specific user account allows you to differentiate roles and permissions based on the following levels:

- **Level 0:** standard user authorized only to view data (measurements and station status);
- **Level 1:** Owner user authorized to configure and update the station;
- **Level 2:** administrator user with full permissions (system service and configuration)

Once logged in and the main page (**Home page**) has opened, the user can continue browsing.

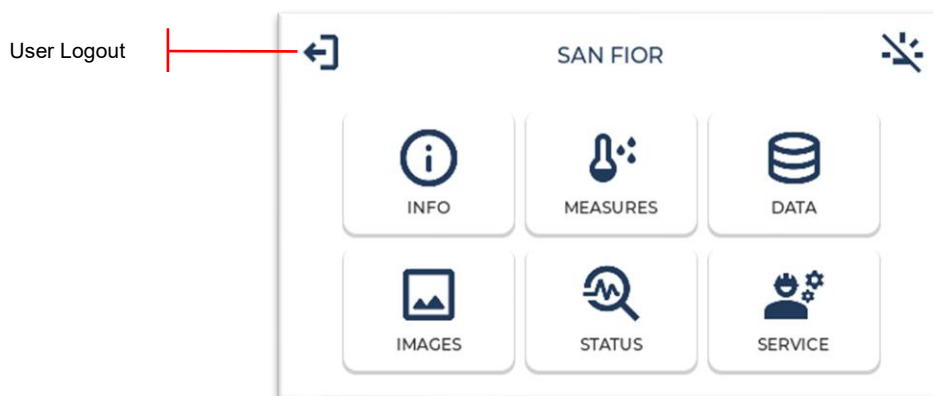



*Main screen (Home page)*

From the main screen, you can access:

1. INFO – Station information
2. MEASURES – Current measurement values
3. DATA – Recorded data values
4. IMAGES – Images recorded by the webcam (if available)
5. STATUS – Data logger status
6. SERVICE – Service operations

To return to the home page, use the following buttons/icons:

-  *Back* Return to the previous page
-  *Home* Return to the main page

If you are inactive for more than 60 minutes, your current session will be automatically closed and you will need to log in again. To manually end your session, click the **Logout** icon on the main screen



### 4.2.3 Station Information

---

The **INFO** page allows you to view the station's basic information.

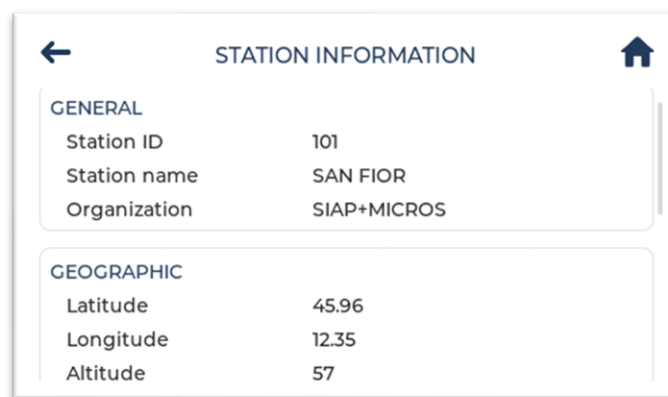

*Station Information Screen*

In detail:

#### General Information

- Station ID;
- Station name;
- Organization;

#### Geographic coordinates

- Latitude;
- Longitude;
- Altitude;

#### Date and time

- Local time zone;
- NTP (Network Time Protocol) time synchronization server;
- Internal clock (RTC) update interval;

#### Communication settings

- Device ID (Modbus);
- Listening TCP/IP port and communication protocol;
- COM1...COM9 serial ports enabled for communication and communication protocol;
- TUNNEL server address and communication protocol;

## 4.2.4 Current Measurements

The **MEASURES** page displays a real-time list of measurement sensors and their respective acquired values. Only the elements configured in the display section are included in the list.

To scroll through the measurements, drag the list in the desired direction.

The page normally refreshes every 3 seconds.

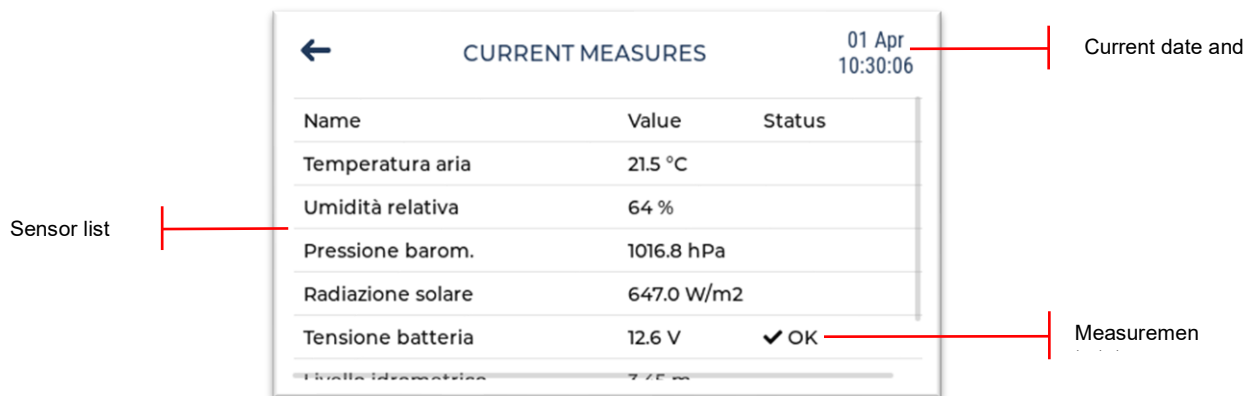

Current measurements screen

Details of displayed fields:

- Measurement name;
- Value and engineering unit;
- Measurement status;

The measurement status is displayed only if the acquired sensor has an associated alarm control; otherwise, it will not be displayed. Possible status values are:

✓ OK	Normal measurement (within threshold limits)
⚠ HIGH / LOW WARNING	Pre-alarm measurement (high or low warning threshold exceeded)
🔔 HIGH / LOW ALARM	Alarm measurement (high or low alarm threshold exceeded)
✘ ERROR / OUT OF RANGE	Acquisition error or out-of-range measurement
⏸ PAUSE	Sensor under maintenance (recording paused)

To return to the previous page, tap the *Back* icon  
 or to return to the main page, tap the *Home* icon



## 4.2.5 Data h

The **DATA** page displays a tabular report of the latest data recorded in the archive (latest historical record).

To scroll through the displayed data, drag the table in the desired direction.

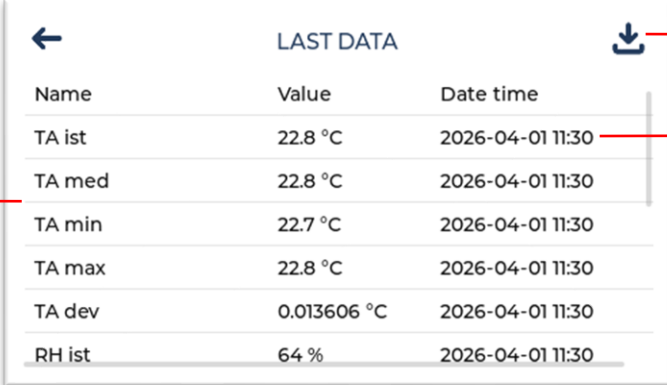

The screenshot shows a mobile interface titled "LAST DATA". It features a table with three columns: "Name", "Value", and "Date time". The table contains seven rows of data. A red arrow labeled "Data report" points to the table. Another red arrow labeled "Data export" points to a download icon in the top right corner. A third red arrow labeled "Date and time of recording" points to the "Date time" column.

Name	Value	Date time
TA ist	22.8 °C	2026-04-01 11:30
TA med	22.8 °C	2026-04-01 11:30
TA min	22.7 °C	2026-04-01 11:30
TA max	22.8 °C	2026-04-01 11:30
TA dev	0.013606 °C	2026-04-01 11:30
RH ist	64 %	2026-04-01 11:30

*Historical data screen*



The page refreshes at intervals equal to the minimum recording interval.

The fields displayed in detail:

- Data name;
- Value and engineering unit;
- Recording date and time;

From this page, the user can export and save the data to an external storage device (SD card or USB drive). The generated file can contain up to 31 days of data.

### Data export and download procedure

1. Insert the external storage device (SD card or USB drive).
2. Click the  download icon. A dialog box will open for selecting the export.
3. Select the start and end dates of the period (the maximum allowed period is 31 days).
4. Select the desired format from the available options (for example: *CSV report - wide table*).
5. Start the export by pressing OK 



*Data Export*

6. Once the export is complete, a window will open to select the location where you want to save the file.
7. Select the destination folder and confirm the data download by clicking YES. The following message will confirm the success of the operation:

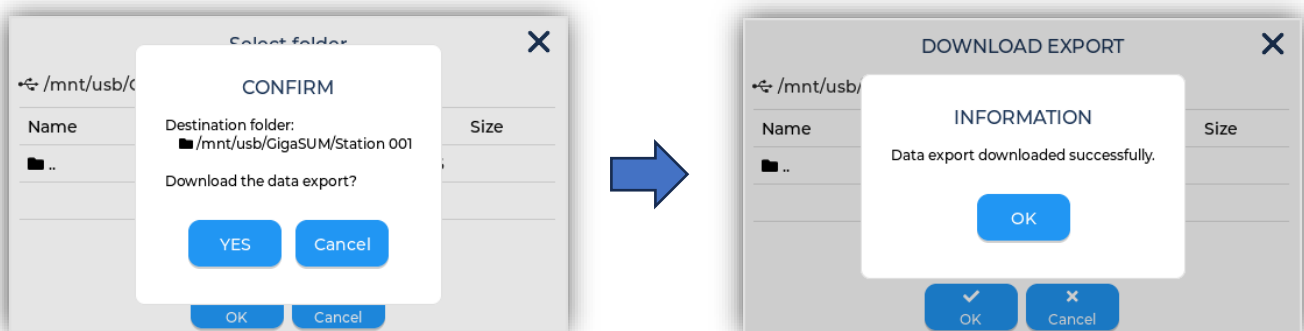

*Export download*

## 4.2.6 Data Logger Status

The **STATUS** page provides access to two information screens:

1. CONNECTIONS STATUS – Status of the data logger’s connections.
2. STORAGES STATUS – Status of the data archives.

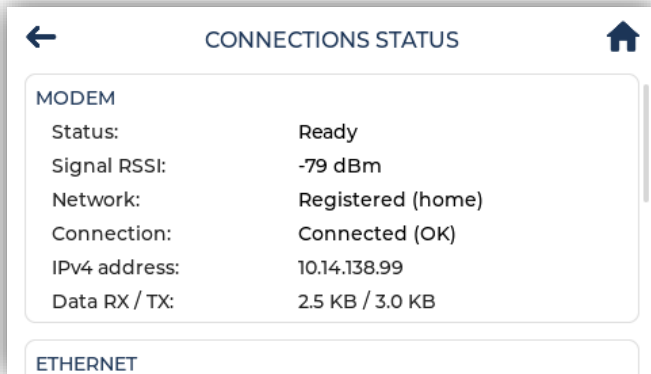

Connection status

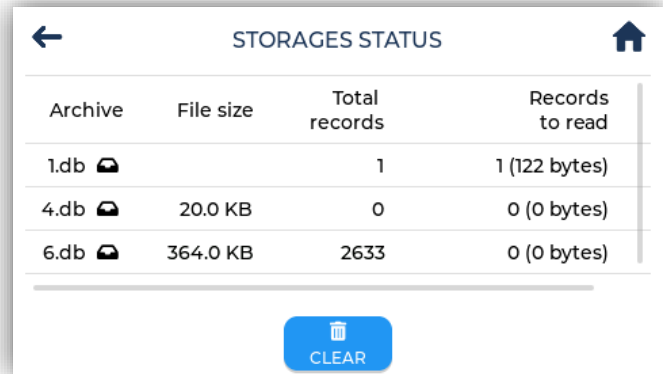

Archive Status

The CONNECTIONS STATUS screen displays the statuses of the data logger’s communication channels. Specifically:

### MODEM

- Communication status (Ready, Disabled, Error);
- Received signal strength (RSSI);
- Network and mobile operator registration status;
- PPP (Point-to-Point) connection status;
- Assigned IPv4 address;
- Data received and transmitted (KB);

### ETHERNET

- Interface name (eth0);
- Status (UP/DOWN, RUNNING/NOT RUNNING);
- IP address;
- Netmask;
- MAC address;
- Data received and transmitted (MB);

### INTERNET

- Connection status (Online, Offline);

### TUNNEL

- Communication status (Connected, Disconnected);

To view all available information, scroll vertically down the page.

The STORAGES STATUS screen displays a list of the log databases currently configured and in use in the data logger. The list allows you to check the size, number of records, and transfer progress.

The following information is displayed for each archive:

- Archive file name (.db);
- Current file size;
- Total number of stored records;
- Number of records still to be read or transferred;

Scroll through the list both vertically and horizontally to view all available fields.

### Archive cleanup procedures

#### 1. CLEAR ARCHIVE

If you need to delete data from a single archive, click the *Trash* icon at the end of the row. If you are sure about this action, confirm with YES:

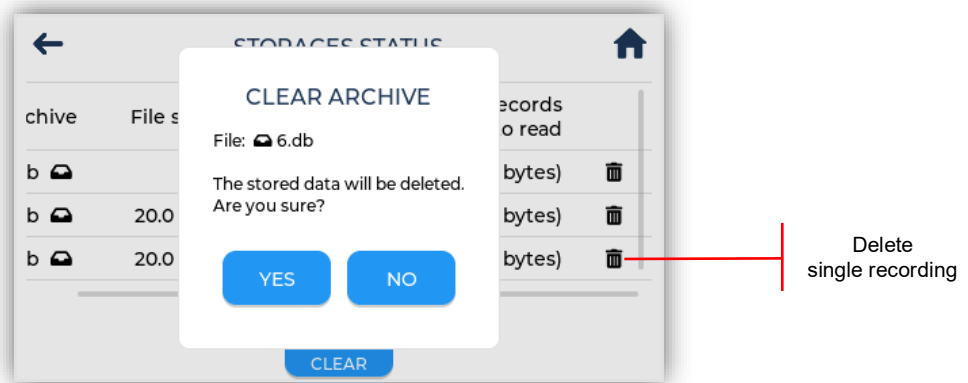

#### 2. CLEAR ALL

To delete all existing logs and start from scratch (complete reset), press the central CLEAR button and confirm with YES when the warning message appears. Warning! All recorded data will be permanently deleted:

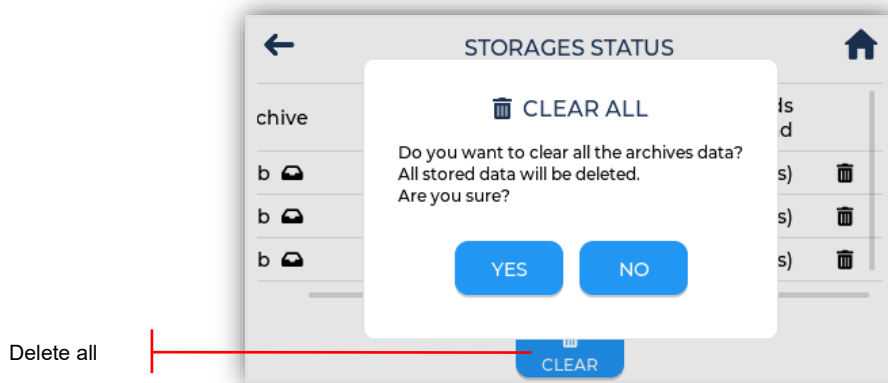

## 4.2.7 Service Functions

---

The **SERVICE** page provides access to the data logger's service functions. Since these operations can alter the system's behavior, access is restricted to users with appropriate permissions.



*Service Screen*

From this screen, you can access:

1. **PARAMETERS** – Modify configuration parameters.
2. **CONFIGURATION** – Managing the data logger's configuration.
3. **APPLICATION** – Updating the application firmware.
4. **MAINTENANCE** – Maintenance service.
5. **LOG** – Log.
6. **SYSTEM** – System settings.

## 4.2.8 Parameters

The **PARAMETERS** page displays the list of parameters defined in the data logger configuration. Each parameter is identified by:

- Numeric ID
- Name
- Value

The values associated with the parameters are used within the configuration to manage various functions, such as calculation expressions, alarm thresholds, time intervals, and other operational logic.

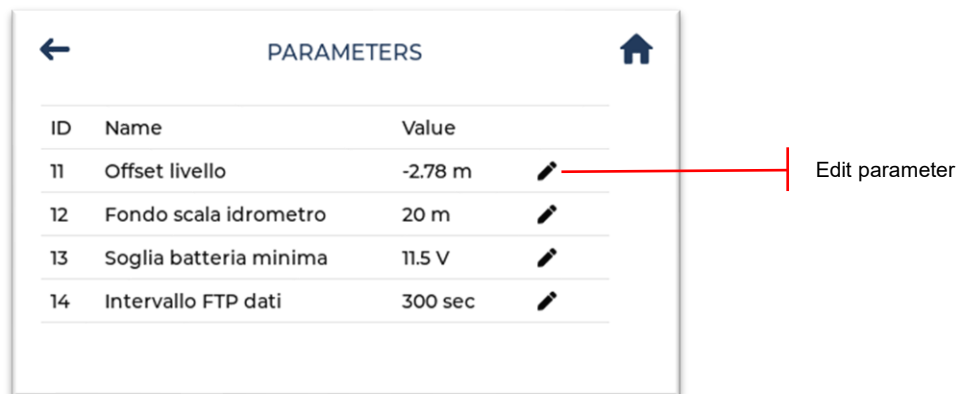

Parameters screen

To change a parameter value:

1. Press the **Edit** icon next to the parameter you want to change (the edit window will open).
2. Use the numeric keypad to enter or change the value.
3. Press OK to confirm and save the change.



Edit parameter

## 4.2.9 Configuration

The **CONFIGURATION** page displays the status of the configuration and settings files currently in use in the data logger (*cnf.xml* and *ini.xml*). The following information fields are displayed for each file:

- Name.
- Date of last modification.
- Size (KB).

If the screen does not display any files, it indicates that the data logger has not yet been configured.

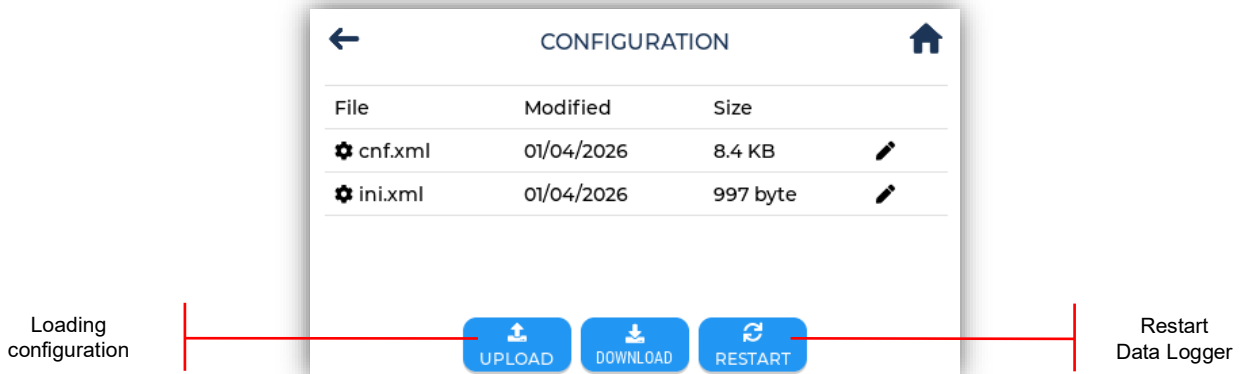

Configuration screen

Using the **UPLOAD** and **DOWNLOAD** buttons, the user can manage the uploading and downloading (copying) of files, respectively, using an external storage device.

### Configuration upload procedure

To upload a new configuration (or settings) file, follow these steps:

1. Insert the external storage device (SD card or USB drive) containing the files to be uploaded.
2. Press the **UPLOAD** button. A dialog box will open to browse the device.
3. Select the new file (.xml) to transfer and press **OK**.

At the next prompt, press **YES** to confirm your selection (or *Cancel* to cancel the operation):

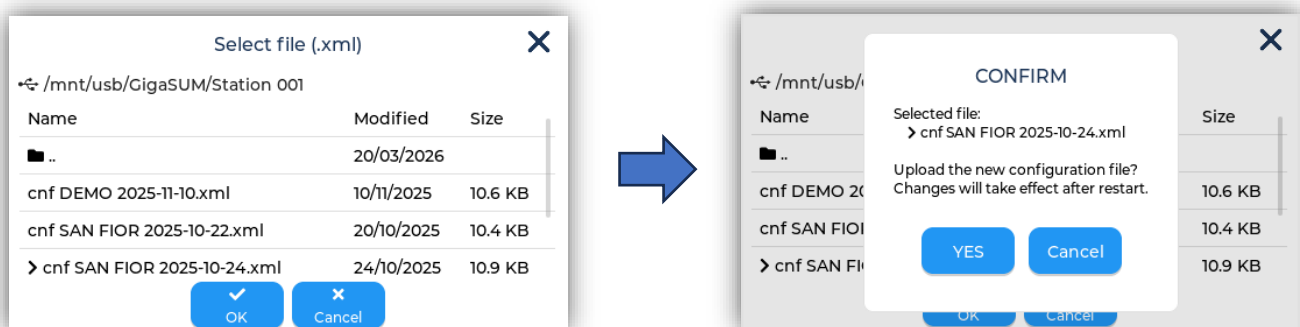

Select new configuration file

After confirmation, the new file will appear in the list as *new\_cnf.xml* or *new\_ini.xml*.



To apply the changes, you must restart the software application when finished. Press the **RESTART** button and confirm the  restart with **YES**:



*Datalogger Restart – Configuration Upload*

### Configuration download procedure

To make a copy of both the configuration and settings files, proceed as follows:

1. Insert the external storage device (SD card or USB drive) where you want to save the files.
2. Press the  **DOWNLOAD** button. A dialog box will open to browse the device.
3. Select the destination folder path where you want to save the files and press **OK** 

The following message will confirm the success of the operation:

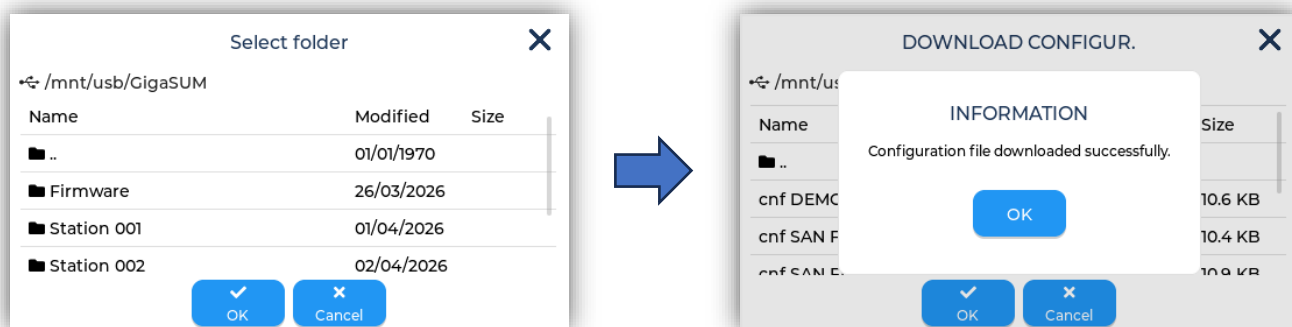

*Folder Selection - Configuration Download*

The files will be saved with the following naming convention:

- cnf <station name> <year-month-day>.xml
- ini <station name> <year-month-day>.xml

### 4.2.10 Application firmware

The **APPLICATION** page displays information regarding the application firmware currently running on the data logger. Specifically:

- File name and version (da20k).
- Date of last modification.
- File size (MB).

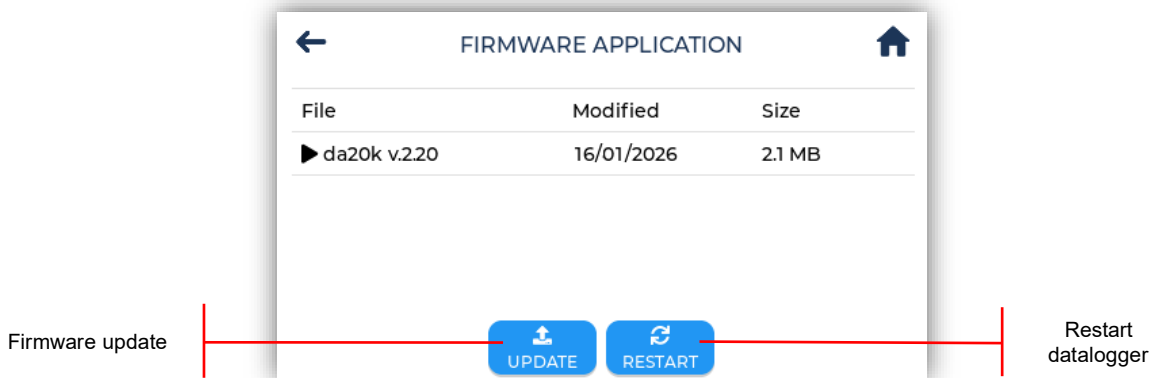



Application firmware screen

The application firmware can be easily updated by using an external storage device to transfer the new file (da20k v\*\*\*.zip).

#### Firmware Update Procedure

To upgrade to new firmware, proceed as follows:

1. Insert the external storage device (SD card or USB drive).
2. Press the UPDATE  button. A dialog box will open to browse the device.
3. Select the new file (da20k v\*\*\*.zip) and press OK .

When the next message appears, press YES to confirm your selection (or *Cancel* to cancel the operation).

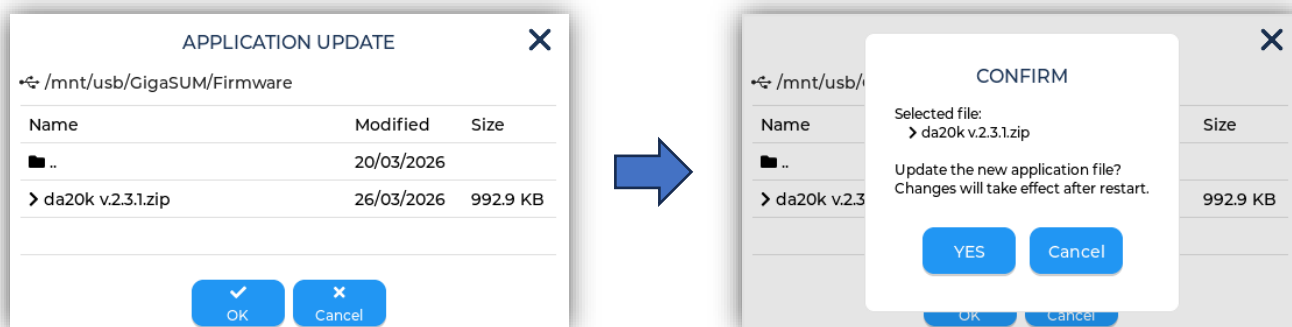

Select new application file

After selection, the screen will show that the new **da20k.zip** file has been loaded but not yet replaced. To apply the update, you must restart the software. Press the RESTART button and then confirm the restart with YES: 

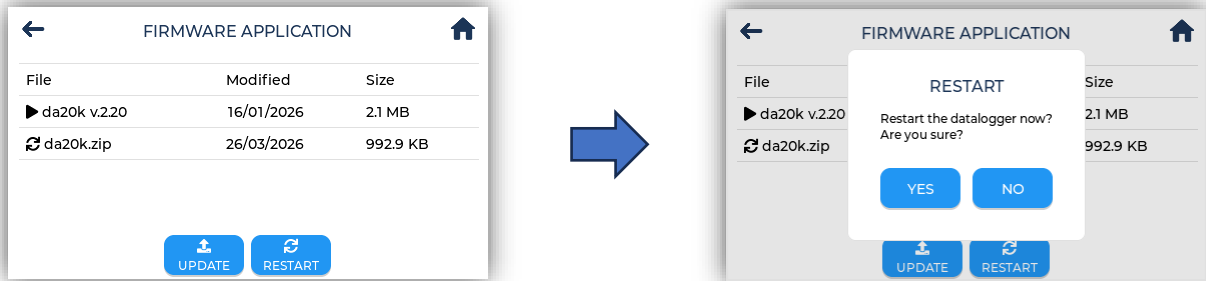

*Restart data logger – Update application firmware*

## 4.2.11 Maintenance

The **MAINTENANCE** function allows maintenance personnel to temporarily pause the data logger service to perform maintenance on the measurement sensors.

To pause the data logger service, confirm the request by pressing YES. The **||** display will automatically switch to the screen showing current measurements, which will appear in PAUSE status:

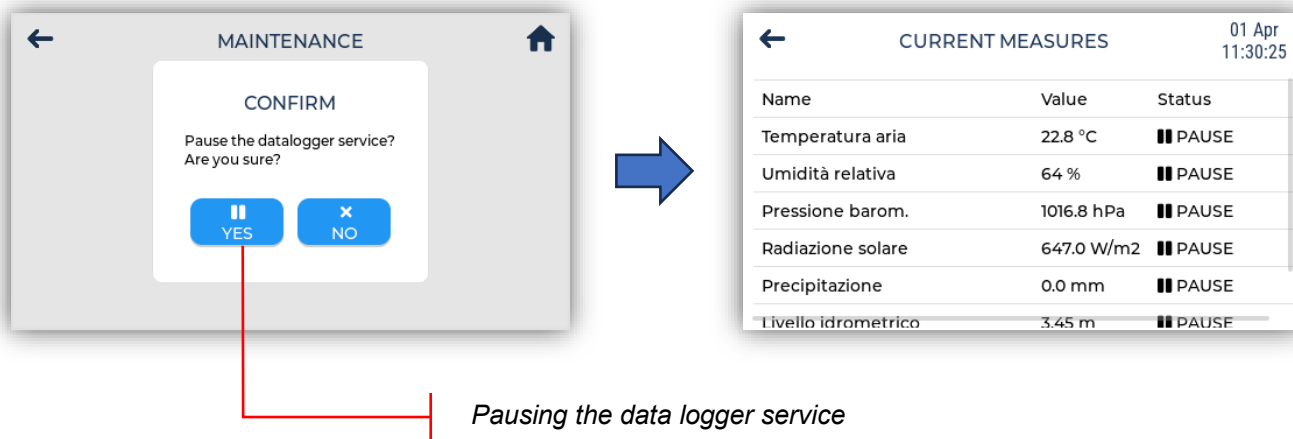

In this mode, the data logger disables data recording to prevent the acquisition of inaccurate measurements.

Once complete, the service can be reactivated by going back and confirming the restart **▶** with YES:

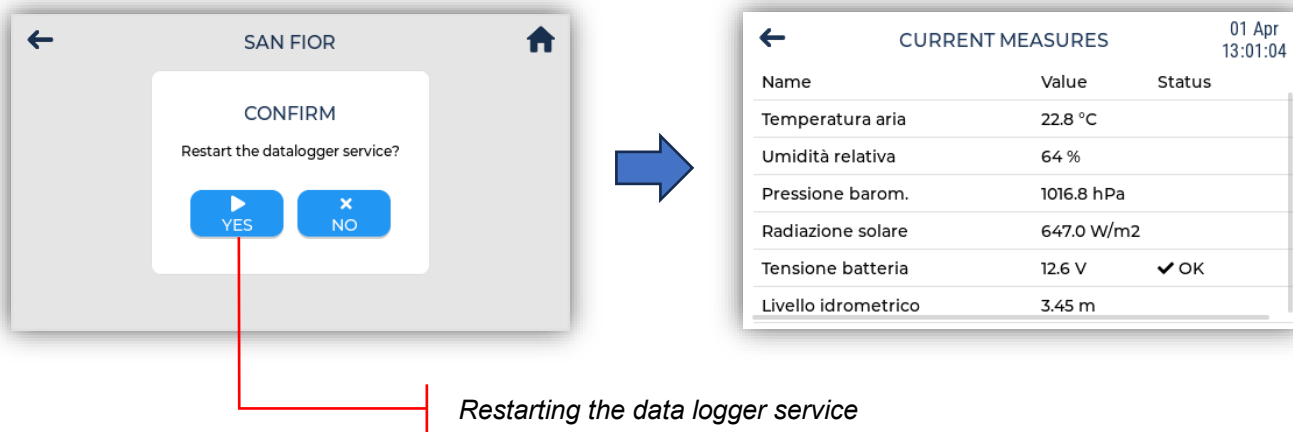

If the service is not restarted, it will automatically restart after 4 hours of inactivity.

## 4.2.12 Log

The **LOG** page displays application events recorded during operation in real time.

Messages are categorized by type:

- **[info]** – General information such as connection status, startup logs, and operational messages;
- **[warning]** – Alerts related to the data logger's operation;
- **[error]** – Communication errors, anomalies, or malfunctions;

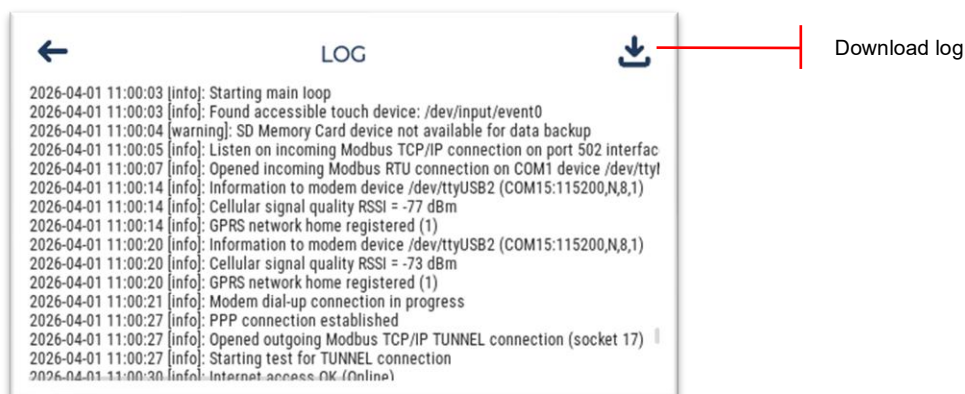

To view the messages properly, you can scroll through the list both vertically and horizontally.



Log screen

From this screen, you can download a copy of the log files to an external storage device (SD card or USB drive). The generated file will contain logs from the last 30 days and is provided in compressed tar.gz format.

### Log download procedure

8. Insert the external storage device.
9. Tap the download  icon. A dialog box will open to browse the device.
10. Select the destination folder path where you want to save the files and press OK 

The following message will confirm the success of the operation:

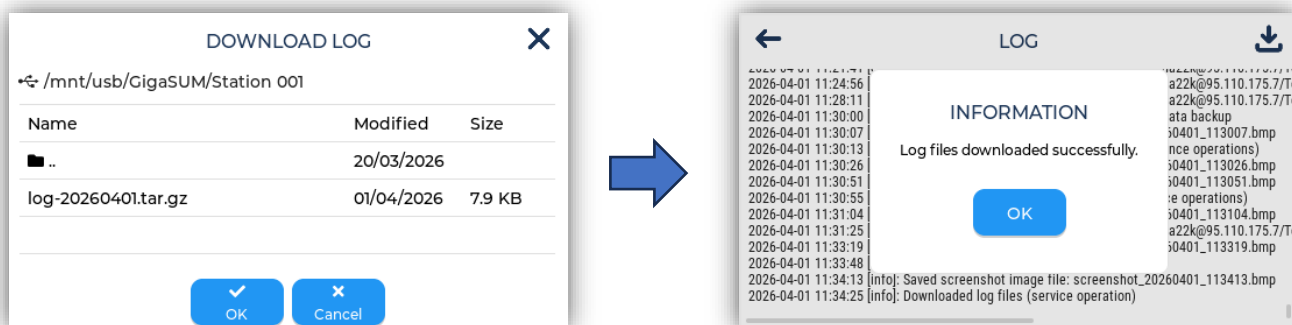

Download log file

### 4.2.13 System

Access to the **SYSTEM** page is restricted to users with administrator privileges and allows you to directly modify certain system settings.

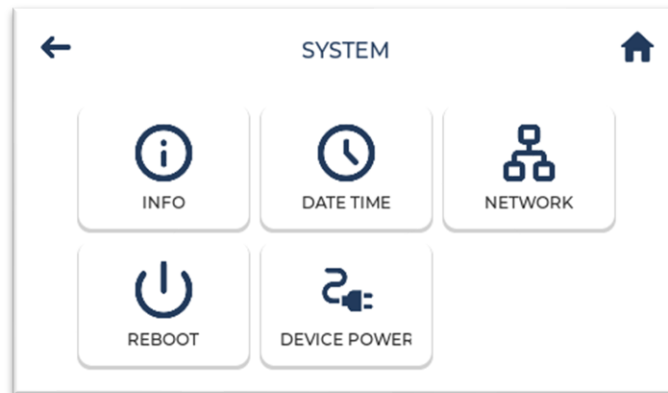

System screen

From this screen, you can access:

1. INFO – System information (Linux Embedded).
2. DATE & TIME – Clock settings.
3. NETWORK – Network interface settings.
4. REBOOT – System reboot.

### 4.2.14 System Information

The **SYSTEM INFO** page allows you to view information about the status of the running Linux Embedded system.



System Information Screen

Specifically:

- System Information
  - Operating System Version;

- Kernel version;
- Total uptime;

#### CPU

- Hardware model;
- Usage percentage;
- Internal temperature (if available);
- Average load indicators;

#### Memory and storage

- Total and used RAM;
- Disk swap;
- File system space (total and used);
- SD card space (total and used);

### 4.2.15 Date & Time

The **SYSTEM CLOCK** page allows you to set the system clock and local time zone.

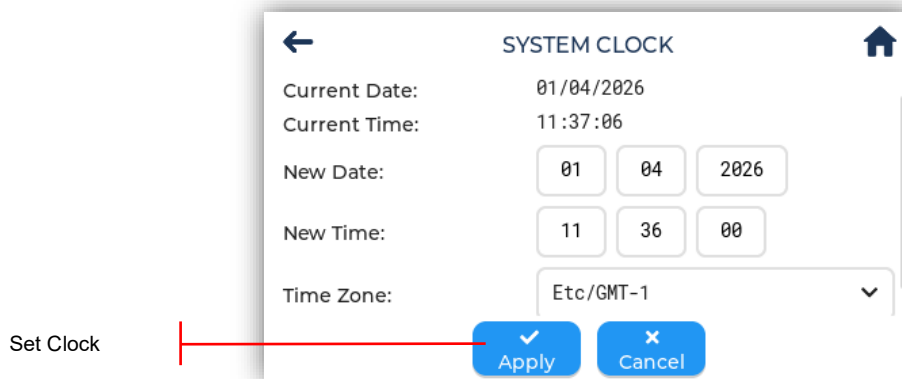

*Clock screen*

To change the date and time, scroll/rotate the respective fields up or down:

*New date: **day, month, year***

*New time: **hour, minutes, seconds***

To change the time zone, select the option from the drop-down list (*Time Zone*).

When finished, press the *Apply* button to permanently save the changes. ✓

The changes are applied to both the system clock and the internal hardware clock (RTC), which will then be synchronized with each other.

Important! The data logger settings, normally contained in the *ini.xml* file, include both automatic clock synchronization (NTP) and the local *time zone*, so changes made through this page will be overwritten upon the first system reboot or the first time update.

Note: For technical reasons, it is recommended to set only *time zones* of the **Etc/GMT±h** type, i.e., those that do not observe daylight saving time (DST). Furthermore, as in all POSIX/Linux systems, the convention regarding the sign of the time to be added or subtracted is the opposite of the one commonly used (e.g., GMT-1 corresponds to UTC+1).

## 4.2.16 Network

The **NETWORK** page can be used to configure the Ethernet network interface (eth0).

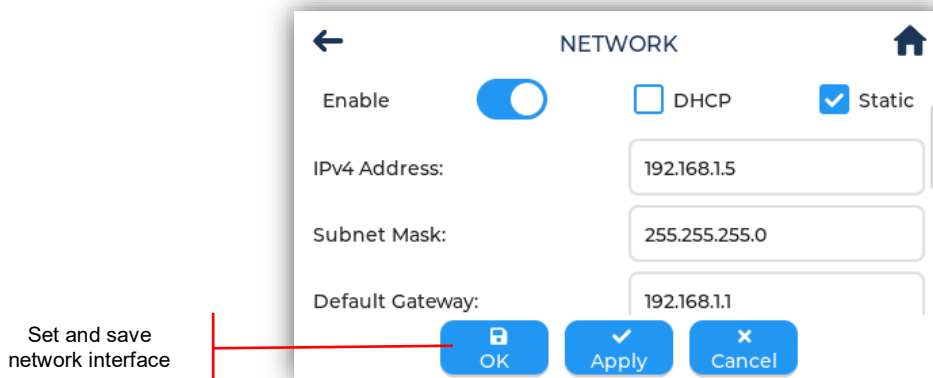

*Network screen*

If the network is enabled, you can modify and save the following settings:

### Mode

- DHCP (automatically obtains an IP address);
- Static (uses the set IP address);

### IP

- IPv4 Address;
- Subnet Mask;
- Default gateway;

### DNS Server

- Primary DNS;
- Secondary DNS;

## 4.2.17 Reboot

The **REBOOT** button allows you to restart the operating system. Press  YES to confirm the restart.

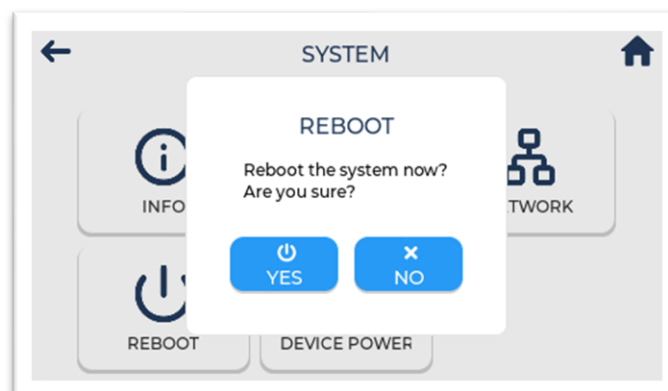

*Reboot screen*

### 4.2.18 Device Power

The **DEVICE POWER** page allows you to set the power (ON/OFF) for the following datalogger devices:

- Power to the Ethernet switch (physical);
- Internal xG modem power;
- 12V auxiliary power supplies (serial COM2, COM3, COM4, COM5, and COM6);

To instantly enable or disable a single power supply, use the switch associated with it:

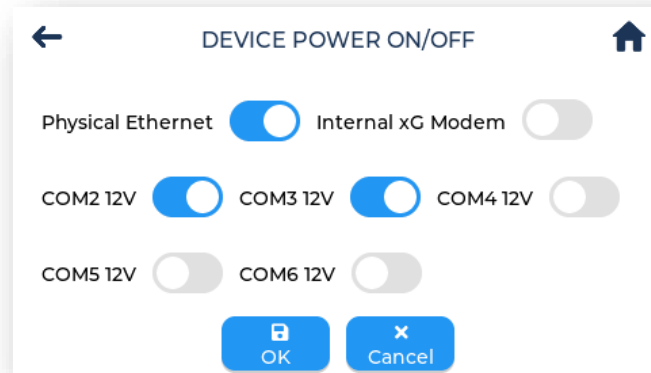

Device Power Screen

By pressing OK and confirming with YES, the settings made will be permanently saved in the initialization file (*ini.xml* file).

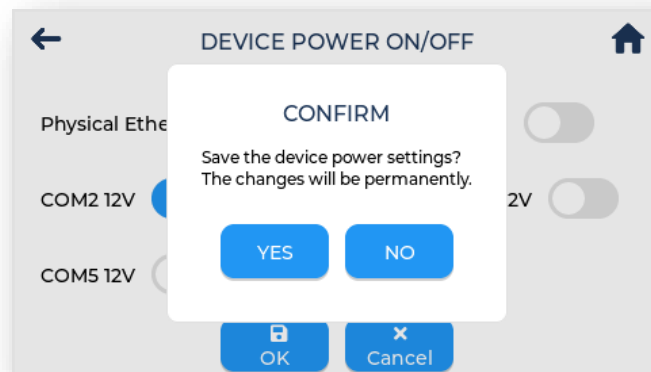

## 4.3 Data logger configuration

The configuration settings required for the data logger to function are contained in the following files:

- **ini.xml** Initialization file
- **cnf.xml** Configuration file

Upon startup, the data logger application loads these settings and uses them as operating instructions for the program. Note that data loggers with factory settings do not include these files.

The content of each file is structured in XML and is generally generated and sent to the data logger via configuration management software. Alternatively, the files can also be created or edited manually using a text editor compatible with the XML format.

For configuration creation and management, please refer to the **DAK** application software, following the instructions provided in the **s012-d DAK manual—SIAP+MICROS Data Logger Programming Manual**.

The following sections describe in detail all supported XML elements. For demonstration purposes, examples of the files are shown using the **Notepad++** editor.

### 4.3.1 Initialization File

The **ini.xml** initialization file is used to define the device's basic settings, specifically for station identification and for configuring the data logger's communication ports. The settings are organized within the following XML sections:

```
<SYSTEM>
  <INI>
    ...
  </INI>
</SYSTEM>
```



```
1 <?xml version="1.0" encoding="ISO-8859-1"?>
2 <!--Setting created by S+M DAK v 3.7 on 23/set/2024 10:00:00-->
3 <SYSTEM>
4   <INI device-id="1" storage-id="101" station-name="Stazione idrometrica" time-zone="Etc/GMT-1">
5     <BACKUP enable="1" path1="/mnt/sd" path2=""/>
6     <CONNECTIONS>
7       <TCP port="502" protocol="2" max="1"/>
8       <COM1 bps="9600" protocol="2" rts="3"/>
9       <TUNNEL ip="95.110.175.222" port="30101" protocol="2" echo="A" scan="10"/>
10    </CONNECTIONS>
11    <PPP isp-name="internet" persist="1" test-url="www.google.com"/>
12    <NTP sync="360" server="pool.ntp.org"/>
13    <RTC sync="60"/>
14    <WD scan="1" run-timeout="60" data-timeout="21600"/>
15    <MODEM info="AT+CSQ:AT#SERVINFO"/>
16  </INI>
17 </SYSTEM>
18
```

Example of the *ini.xml* file

The following is a detailed description of all the elements that can be included in the initialization file. Some attributes may take default values if omitted.

#### General and Geographical Settings

- **device-id**: device identifier (MODBUS communication ID). Range: 1–247, Default = 1.
- **storage-id**: data storage identifier (Station ID). Range: 1–9999, Default = *device-id*.
- **station-name**: station name.
- **org**: owner organization.
- **lat**: latitude (DD).
- **lon**: longitude (DD).
- **alt**: altitude (m.a.s.l.).
- **time-zone**: local time zone (IANA standard). Default = UTC

Notes:

The most commonly used time zone format is of the type *Continent/City* (e.g., *Europe/Rome*), but these formats automatically adopt the switch to daylight saving time (DST).

To avoid DST, you must use time zones of the form: *Etc/GMT*, *Etc/GMT-1*, *Etc/GMT+1*, etc. In this case, no automatic clock adjustments will be made throughout the year, and the time reference will remain constant.

It is important to note that the notation used by Linux/Posix for time zones of the type *Etc/GMT* is the opposite of the commonly used convention. Specifically:

*Etc/GMT-1* corresponds to GMT+01 (one hour ahead of UTC)

*Etc/GMT+1* corresponds to GMT-01 (one hour behind UTC)

### Users for display access

**<USERS/>**

- **name**: username;
- **pwd**: password hash (\$1\$...);
- **level**: access level (0=Standard, 1=Owner, 2=Administrator);

This setting enables the login screen, requiring the entry of login credentials (username and password).

### Incoming connection for serial communication with the data logger <sup>(1)</sup>

**<COMx/>**

- **bps**: serial speed (baud rate: 1200, 2400, 4800, 9600, 19200, 38400, 57600, 115200);
- **protocol**: communication protocol (1=S&F, 2=MODBUS, 3=SDS TETRA, 4=PSE) <sup>(2)</sup> ;
- **rts**: RTS handshake setting (0=Disable, 1=Enable, 2= , 3=Toggle). Default = 3;

This setting enables the COMx serial port to receive data (e.g., COM1).

### Incoming connection for TCP/IP communication with the data logger <sup>(1)</sup>

**<TCP/>**

- **ip**: specific IP address on which to enable listening (optional). Default = "" (all);
- **port**: TCP port to listen on (Default = 502);
- **protocol**: communication protocol (1=S&F, 2=MODBUS, 3=SDS TETRA, 4=PSE) <sup>(2)</sup> ;
- **max**: maximum number of accepted connections ( ). Default = 3;

This setting enables the opening of a *TCP/IP server* listening on the specified port (e.g., 502).

### Outgoing connection to a remote tunnel server

**<TUNNEL/>**

- **ip**: IP address of the tunnel server to which the data logger must connect;
- **port**: TCP port of the tunnel server (left side for the station);
- **protocol**: communication protocol (1=S&F, 2=MODBUS, 3=SDS TETRA, 4=PSE) <sup>(2)</sup> ;
- **echo**: *keep-alive* " " sent periodically to keep the connection active (default = "A");
- **scan**: *keep-alive* transmission interval (Default = 10 sec.)

This mode allows the data logger to be reached via a port-to-port TCP/IP connection on a server running the *Sockets Tunnel* software.

### Data backup to external storage devices (SD Memory Card and/or USB Flash Drive)

#### <BACKUP/>

- **enable**: Enable backup copying (0=Disable, 1=Enable).
- **path1**: mount point */mnt/sd* for backup to SD card (primary drive);
- **path2**: mount point */mnt/usb* for backup to USB disk (secondary drive);  
Default = " (not present);

### 3G/4G Modem

#### <MODEM/>

- **com**: serial port to which the modem is connected (Default: 15 = USB2);
- **baud**: modem serial speed (Default: baudrate = 115200);
- **info**: specifies one or more additional AT commands to obtain information on the RSSI signal, network registration, mobile carrier, etc. (e.g., "AT+CSQ");

### PPP (Point-to-Point Protocol) Connection

#### <PPP/>

- **isp-name**: name of the PPP connection configuration provider file. The file must be located in the system directory: */etc/ppp/peers* (Default: internet);
- **persist**: specifies whether the PPP connection should be persistent (1 = always active) or activated on demand (0 = only when requested), for example before initiating an FTP data transfer. Note: if a tunnel connection is present, PPP persistence must be enabled;
- **test-url**: URL or remote IP address used to test Internet access (Default = *www.google.com*);

### DDNS (Dynamic Domain Name System) Client

#### <DDNS/>

- **url**: Specific URL for updating the IP address (e.g., <https://dynupdate.no-ip.com/nic/update>)
- **username**: username registered with the service;
- **password**: login password;
- **hostname**: associated domain name;

The DDNS service allows you to automatically associate a domain name with the data logger's dynamic IP address, even if the address changes over time (e.g., domain: *gigasum-0001-siapmicros.ddns.net*).

## NTP (Network Time Protocol) Client

<NTP/>

- **sync**: synchronization interval (minutes); Default: 360 minutes;
- **server**: time server name (Default time server: [pool.ntp.org](http://pool.ntp.org))

NTP is used to update the data logger's clock with a precise time reference from a network time server. NTP synchronization updates both the system clock and the RTC hardware clock.

## RTC (Real-Time Clock) device

<RTC/>

- **sync**: synchronization interval (minutes); Default: 60 minutes;

RTC is an internal hardware component used to synchronize the system clock with a more precise time reference.

## Hardware Watchdog

<WD/>

- **scan**: pulse period of the WD digital output (seconds). The pulse is intended for the MCU board's watchdog (activity LED). If the pulse is not received, the board cuts power to reset the data logger.
- **run-timeout**: maximum inactivity time for the main loop (Default: 60 seconds);
- **data-timeout**: maximum time without data transfer. Set to 0 to disable this check (Default: 86,400 seconds);

The hardware watchdog is used to ensure the device operates correctly. It resolves situations where the system is frozen or unresponsive by automatically restarting it.

If the set time limits expire (timeout), the internal process sends a specific command to the MCU board, which immediately triggers a reboot of the data logger.

## Device Power (ON/OFF)

<DEVICE-POWER />

- **modem, ethernet, wifi, com2\_12v, com3\_12v, com4\_12v, com5\_12v, com6\_12v**: device power management flag (1=ON, 0=OFF); Default: 1;

<sup>(1)</sup> Default connection: if no input connections are configured, the data logger will still be accessible via:

- Serial port COM1 at 9600 bps using the *Modbus RTU* protocol
- TCP/IP port 502 listening in *Modbus TCP/IP* protocol

<sup>(2)</sup> The following protocols are currently unavailable:

- S&F (obsolete)
- SDS TETRA (not implemented)

## 4.3.2 Configuration file

The **cnf.xml** configuration file contains the settings and functions programmed by the user to define the data logger's operating cycle.

The settings are organized within the following XML sections:

<CONFIG>	
<PARAMETERS>	<i>Definition of parameters used in the configuration</i>
<ACQUISITIONS>	<i>Configuration of sensor acquisition and measurement channels</i>
<PROCESSING>	<i>Implementation of functions for processing acquired data</i>
<CONTROLS>	<i>Output control logic and operating conditions</i>
<STORAGES>	<i>Configuration of data storage type and format</i>
<TRANSMISSIONS>	<i>Configuration of data transmission channels</i>
<DISPLAY>	<i>Setting the measurements displayed on the local interface</i>
</CONFIG>	

```

1  <?xml version="1.0" encoding="ISO-8859-1"?>
2  <!--Configuration created by S+M DAK v 3.7 on 23/set/2024 10:00:00 ClassLib v. 1.3.0-->
3  <CONFIG>
4  <REMARKS>
5  <REMARK name="1.0.0" CIsId="REMARK" author="SIAP+MICROS" note="Configurazione stazione idrometeo"/>
6  </REMARKS>
7  <PARAMETERS>
8  <PARAMETER name="Offset livello" CIsId="PARAMETER" id="11" unit="m" value="-2.78"/>
9  <PARAMETER name="Fondo scala idrometro" CIsId="PARAMETER" id="12" unit="m" value="20"/>
10 <PARAMETER name="Soglia batteria minima" CIsId="PARAMETER" id="13" unit="V" value="11.5"/>
11 <PARAMETER name="Cadenza FTP dati" CIsId="PARAMETER" id="14" unit="sec" value="300"/>
12 </PARAMETERS>
13 <ACQUISITIONS>
14 <SENSOR name="Scheda BASE15K - Misure ingressi analogici/digitali" CIsId="BASE15K AI" type="2" id="1" com="2" baud="57600" scan=
15 <CHANNEL name="TAN" CIsId="PT100_CH01" enab="1" addr="300001" type="5" expr="" low="-30" upp="60" tag="30"/>
16 <CHANNEL name="RHN" CIsId="SING_CH05" enab="1" addr="300017" type="5" expr="(M0+1e-6)+100" low="0" upp="100" tag="32"/>
17 <CHANNEL name="RLS" CIsId="SING_CH08" enab="1" addr="300023" type="5" expr="$12*(M0+1e-6-0.4)/1.6" low="0.30" upp="20" tag="
18 <CHANNEL name="PLUV" CIsId="COUNT_DIAD03" enab="1" addr="300063" type="3" expr="M0+0.2" low="0" upp="+2E9" tag="40"/>
19 <CHANNEL name="VBAT" CIsId="V_BATT" enab="1" addr="300079" type="5" expr="" low="0" upp="24" tag="48"/>
20 </SENSOR>
21 <SENSOR name="Acquisizione interna" CIsId="SYSTEM" type="0" scan="10000">
22 <CHANNEL name="LIV" CIsId="GET_TAG" addr="0035" type="0" expr="($12-M0)+$11" low="-5" upp="15" tag="36"/>
23 </SENSOR>
24 </ACQUISITIONS>
25 <PROCESSINGS>
26 <PROCESSING name="Elab. PLUV" CIsId="ELAB_PLUV" type="3" scan="300" shift="0" rate="0" tag_inpl="0040" tag_outl="100" tag_out2=
27 <PROCESSING name="Elab. P24H" CIsId="ELAB_PLUV" type="3" scan="86400" shift="0" rate="0" tag_inpl="0040" tag_outl="111" tag_out2
28 <PROCESSING name="Elab. TA" CIsId="ELAB_STD" type="1" scan="1800" shift="0" rate="50" param1="0" param2="0" tag_inpl="0030" tag_
29 <PROCESSING name="Elab. RH" CIsId="ELAB_STD" type="1" scan="1800" shift="0" rate="50" param1="0" param2="0" tag_inpl="0032" tag_
30 <PROCESSING name="Elab. LIV" CIsId="ELAB_STD" type="1" scan="900" shift="0" rate="50" param1="0" param2="0" tag_inpl="0036" tag_
31 <PROCESSING name="Elab. VBAT" CIsId="ELAB_STD" type="1" scan="1800" shift="0" rate="50" param1="0" param2="0" tag_inpl="0048" ta
32 </PROCESSINGS>
33 <CONTROLS>
34 <ALARM name="Batteria scarica" CIsId="ALARM_MEASURE" type="0" scan="10" tag_inpl="0048" min="$13" prn="" prx="" max="" ret="0.5"
35 </CONTROLS>
36 <STORAGES>
37 <RECORD name="Record istantanei" CIsId="RECORD" id="" type="1" format="0" scan="10" shift="0" file="1" merge="0" backup="0" view
38 <WRITE name="TA ist" CIsId="DATA_FIELD" id="1" type="A" tag="0030" unit="°C" dec="1" hide="0" sts=""/>
39 <WRITE name="RH ist" CIsId="DATA_FIELD" id="2" type="A" tag="0032" unit="%" dec="0" hide="0" sts=""/>
40 <WRITE name="PLUV sum" CIsId="DATA_FIELD" id="3" type="A" tag="0108" unit="mm" dec="1" hide="0" sts=""/>
41 <WRITE name="LIV ist" CIsId="DATA_FIELD" id="4" type="A" tag="0036" unit="m" dec="2" hide="0" sts=""/>
42 <WRITE name="VBAT ist" CIsId="DATA_FIELD" id="8" type="A" tag="0048" unit="V" dec="1" hide="0" sts=""/>
43 </RECORD>
44 <RECORD name="Record allarmi" CIsId="RECORD" id="" type="2" format="0" scan="30" shift="0" file="4" merge="1" backup="0" view="0
45 <WRITE name="VBAT ist" CIsId="DATA_FIELD" id="8" type="A" tag="0048" unit="V" dec="1" hide="0" sts=""/>
46 </RECORD>
47 <RECORD name="Record storici 5'" CIsId="RECORD" id="" type="0" format="0" scan="300" shift="0" file="6" merge="1" backup="0" vie
48 <WRITE name="PLUV sum" CIsId="DATA_FIELD" id="3" type="B" tag="0108" unit="mm" dec="1" hide="0" sts=""/>
49 </RECORD>
50 <RECORD name="Record storici 15'" CIsId="RECORD" id="" type="0" format="0" scan="900" shift="0" file="6" merge="1" backup="0" vi
51 <WRITE name="LIV med" CIsId="DATA_FIELD" id="4" type="B" tag="0216" unit="m" dec="2" hide="0" sts=""/>
52 <WRITE name="LIV min" CIsId="DATA_FIELD" id="4" type="C" tag="0217" unit="m" dec="2" hide="0" sts=""/>
53 <WRITE name="LIV max" CIsId="DATA_FIELD" id="4" type="D" tag="0219" unit="m" dec="2" hide="0" sts=""/>
54 <WRITE name="LIV dev" CIsId="DATA_FIELD" id="4" type="E" tag="0222" unit="m" dec="6" hide="0" sts=""/>
55 <WRITE name="LIV ist" CIsId="DATA_FIELD" id="4" type="A" tag="0225" unit="m" dec="2" hide="0" sts=""/>
56 </RECORD>
57 <RECORD name="Record storici 30'" CIsId="RECORD" id="" type="0" format="0" scan="1800" shift="0" file="6" merge="1" backup="0" v
58 <WRITE name="TA med" CIsId="DATA_FIELD" id="1" type="B" tag="0160" unit="°C" dec="1" hide="0" sts=""/>
59 <WRITE name="TA min" CIsId="DATA_FIELD" id="1" type="C" tag="0161" unit="°C" dec="1" hide="0" sts=""/>

```

Example cnf.xml file

The following sections describe the settings and configurable functions in detail.

### 4.3.3 Main Cycle and Secondary Processes

---

All priority functions for data **acquisition, processing, and storage** are performed by the data logger application within a **main work cycle**.

The execution sequence of the main cycle consists of the following operational steps, in order:

- 1° Acquisition of measurements
- 2° Data processing
- 3° Checks
- 4° Data storage
- 5° Data transmission

When creating the configuration file, the functions are defined in the order described above.

The exception is the measurement acquisition process, which is further divided into *parallel threads*, one for each serial or TCP/IP communication port to which the sensors are connected.

#### Secondary processes

Additional functions that require longer execution times or that could block the main cycle are handled via **separate work processes** (secondary threads).

These include, in particular, data transmission functions and the management of the data logger's communication devices.

Secondary processes executed in parallel include:

- Serial communication thread: management of data reception on **COM1 ... COM9** ports
- TCP/IP communication thread: management of incoming **TCP/IP** connections
- Dial-up modem connection process: **PPP** protocol management
- **Tunnel** server connection process: management of the dedicated communication channel
- **FTP** file transfer process: file upload and download
- Date/time synchronization process: synchronization via **NTP** protocol and **RTC** management
- Display process: updating data on the control panel

### 4.3.4 User parameters

---

The **parameters** section allows you to define and store a set of user-defined parameters in the configuration file. Parameter values can be modified locally via the data logger's display (see Section [3.2.8 – Parameters](#)).

The parameters can be used in the following contexts:

- as flags to enable or disable measurements or other functions;
- within measurement conversion expressions or any other evaluation expression;
- as measurement offsets or alarm thresholds;
- as time intervals for data processing and/or storage;
- for managing phone numbers, IP addresses, or other configuration values.

#### Referencing parameters in the configuration

To reference a parameter within the configuration file, use the following notation:

***\$id***

where ***id*** represents the numerical identifier of the parameter, preceded by the **\$** symbol

Examples: \$11, \$12, \$13

XML example of the PARAMETERS section:

```
<PARAMETERS>
  <PARAMETER name="Level Offset" id="11" unit="m" value="-2.78"/>
  <PARAMETER name="Hydrometer full scale" id="12" unit="m" value="20"/>
  <PARAMETER name="Minimum battery threshold" id="13" unit="V" value="11.5"/>
  <PARAMETER name="FTP data rate" id="14" unit="sec" value="300"/>
</PARAMETERS>
```

#### Parameter configuration

The XML element `<PARAMETER ... />` includes the following attributes:

- **id** – numerical identifier of the parameter;
- **name** – parameter name;
- **unit** – unit of measurement;
- **value** – assigned value;

### 4.3.5 -measurement acquisition

The **measurement acquisition** section allows you to configure the **sensors and/or acquisition devices** connected to the data logger, each with its own communication settings.

Within each sensor, the **measurement channels** to be queried during the acquisition cycle are defined. The raw data obtained from the query undergoes a **pre-processing** phase, which includes:

- conversion to engineering units (if necessary);
- a validity check within the measurement range.

The resulting data is then made available in the assigned memory locations (*tags*).

Below is an example of the XML structure describing the acquisition section for multiple sensors:

```

<ACQUISITIONS>
  <SENSOR name="BASE Board ..." type="2" id="1" com="7" baud="57600" scan="3000" timeout="500">
    <CHANNEL name="TAN" enab="1" addr="300001" type="5" expr="" low="-30" upp="60" tag="30"/>
    <CHANNEL name="RLS" enab="1" addr="300023" type="5" expr="$12*(M0*1e-6-0.4)/1.6" low="0... tag="35"/>
    <CHANNEL name="PLUV" enab="1" addr="300063" type="3" expr="M0*0.2" low="0" upp="+2E9" tag="40"/>
    <CHANNEL name="VBAT" enab="1" addr="300079" type="5" expr="" low="0" upp="24" tag="48"/>
  </SENSOR>
  <SENSOR name="Internal Acquisition" ClsId="SYSTEM" type="0" scan="10000">
    <CHANNEL name="LIV" addr="0035" type="0" expr="($12-M0)+$11" low="-5" upp="15" tag="36"/>
  </SENSOR>
</ACQUISITIONS>

```

#### Sensor configuration (XML element <SENSOR .../>)

- **name** – sensor name;
- **type** – sensor type (identifies the communication protocol):
  0. **Internal system** (variable tags, date/time, RSSI signal, connection statuses)
  1. **Store & Forward** (ISIDL / SISLP)
  2. **MODBUS Standard**
  3. **SDI-12 Standard**
  4. **Generic Serial ASCII**
- **id** – alphanumeric identifier of the sensor's hardware address (e.g., Modbus ID: 1–247);
- **com** – communication port to which the sensor is connected:
  0. LAN (TCP/IP sensor)
  1. COM1 DB9 (RS-232)
  2. COM2 RX/TX (RS-232)
  3. COM3 RX/TX (RS-232)
  4. COM4 A/B (RS-485)
  5. COM5 A/B (RS-485)
  6. COM6 A/B (RS-485)
  7. COM7 A/B (RS-485)
  8. COM8 RX/TX (RS-232)
  9. COM9 A/B (RS-485)
  10. COM2 A/B (RS-485)
  11. COM5 D (SDI-12)
  12. COM6 D (SDI-12)

- **baud** – serial communication speed: 1200, 2400, 4800, 9600, 19200, 38400, 57600, 115200 bps
- **par** – parity: N = None, E = Even, O = Odd; (default: N);
- **data** – number of data bits: 8 – 7 bits; (default: 8);
- **stop**: stop bits: 1 – 2 bits; (default: 1);
- **ip** – IP address (TCP/IP sensor);
- **port** – port (TCP/IP sensor);
- **cmd** – query command (e.g., M! for SDI-12 sensor);
- **head** – ASCII message header;
- **tail** – ASCII message tail;
- **delims** – delimiter characters in the ASCII message (one or more value separator characters);
- **scan** – interval, in milliseconds, at which the sensor is queried (in some cases, the scan interval may be defined separately for each channel);
- **timeout** – maximum response wait time (milliseconds);
- **delay** – delay/pause after acquisition (milliseconds);

#### Channel configuration (XML element <CHANNEL .../>)

- **name** – channel name;
- **enab** – channel enable flag (1 = Scanning, 0 = Not scanning);
- **addr** – channel address (example: for tag variable acquisitions, identifies the internal memory location; for MODBUS sensors, identifies the read address according to the standard data addressing convention<sup>(1)</sup>; for SDI-12 sensors, identifies the value's position in the response).
- **type** – data type:
  - Internal system: 0 = Tag variable, 1 = Date/time, 2 = *n.c.*, 3 = Modem RSSI signal, 4 = Connection status, 5 = Diagnostic measurement
  - Modbus data: 0 = Boolean (0/1), 1 = Signed (16-bit), 2 = Unsigned (16-bit), 3 = Swapped Long (32-bit), 4 = Long integer (32-bit), 5 = Swapped F.P. Little-endian (CDAB), 6 = Floating-Point Big-endian (ABCD)
- **scan** – interval, in milliseconds, at which the channel is polled (if not already specified at the sensor level).
- **conv** – pre-conversion expression for the acquired signal (optional);
- **expr** – conversion expression or correction formula to be applied to the acquired signal to obtain the measured value in engineering units;
- **low** – lower limit of the measurement range (*lower limit*);
- **upp** – upper limit of the measurement range (*upper limit*);
- **tag** – memory location where the acquired measurement is stored (*tag*);

<sup>(1)</sup> Addressing convention for MODBUS data reading:

- (0x) 000001..065536 Function 1: Read Output Coils
- (1x) 100001..165536 Function 2: Read Discrete Inputs
- (3x) 300001..365536 Function 4: Read Input Registers
- (4x) 400001..465536 Function 3: Read Holding Registers

Note: The starting address and the number of registers/coils to be requested are calculated automatically based on the channels entered.

### 4.3.6 Processing Functions

The **processing** section, immediately following the acquisition phase, handles the processing of the acquired measurements at configurable time intervals. **Valid samples** of the input measurements (*tag\_inp*) are fed into the respective processing function for processing.

At the end of the configured interval, each function returns a set of **statistical data** (averages, minimums, maximums, etc.), which are made available at the assigned output locations (*tag\_out*).

Example of an XML section dedicated to processing (PROCESSINGS):

```

<PROCESSINGS>
  <PROCESSING name="Rainfall Processing" type="3" scan="300" shift="0" rate="0" tag_inp1="0040"
tag_out1="100" .../>
  <PROCESSING name="TA Processing" type="1" scan="1800" shift="0" rate="50" tag_inp1="0030" tag_out1="156"
.../>
  <PROCESSING name="RH Processing" type="1" scan="1800" shift="0" rate="50" tag_inp1="0032" tag_out1="170"
.../>
</PROCESSINGS>

```

#### Processing Configuration

The XML element < PROCESSING ... /> includes the following attributes:

- **name** – name of the process;
- **type** – type of analysis:
  1. **Statistical analysis (standard)**
  2. **Moving average**
  3. **Rainfall analysis (rain)**
  4. **Anemometric processing (wind)**
- **scan** – data processing interval (seconds);
- **shift** – interval offset (seconds);
- **rate** – minimum rate of valid data required;
- **param1...paramN** – set of parameters usable in processing (if provided) <sup>(\*)</sup>;
- **tag\_inp1... tag\_inp N** – set of input locations (tags) (measurements).
- **tag\_out1...tag\_outN** – set of output locations (tags) (data).

<sup>(\*)</sup> Commonly used parameters:

1. Data Acceptability Criterion: defines the maximum permissible variation range of the incoming sample relative to the previous one. If the range is exceeded, the incoming sample will not be accepted. Setting this to zero disables the criterion.
2. Standard deviation limit: defines the maximum threshold of the calculated standard deviation, above which the output statistical data will be invalidated: Setting this to zero means the invalidation is not applied.

The following pages list, for each type of processing, the input parameters and corresponding output locations where the data resulting from the process are made available.

### Standard statistical processing

<i>Attribute</i>	<i>Description</i>
<b>param1</b>	→ Data acceptability criterion (maximum permissible variation: 0 = not applied)
<b>param2</b>	→ Standard deviation limit (maximum validation threshold: 0 = not applied)
<b>tag_inp1</b>	→ Instantaneous measurement (input)
<b>tag_out1</b>	← Cyclic counter
<b>tag_out2</b>	← Valid measurement counter
<b>tag_out3</b>	← Percentage of valid measurements [%]
<b>tag_out4</b>	← Sum
<b>tag_out5</b>	← Average
<b>tag_out6</b>	← Minimum
<b>tag_out7</b>	← Lowest minute [daily minute]
<b>tag_out8</b>	← Maximum
<b>tag_out9</b>	← Minute of the maximum [daily minute]
<b>tag_out10</b>	← Variance
<b>tag_out11</b>	← Standard deviation
<b>tag_out12</b>	← Measurement reference (value of the last measurement sample)
<b>tag_out13</b>	← Measurement deviation (deviation of the measurement from the initial sample)
<b>tag_out14</b>	← Last valid measurement snapshot

### Dragging (moving) processing

<i>Attribute</i>	<i>Description</i>
<b>param1</b>	→ Data acceptability criterion (maximum permissible variation: 0 = not applied)
<b>tag_inp1</b>	→ Instantaneous measurement (input)
<b>tag_out1</b>	← Cyclic counter
<b>tag_out2</b>	← Valid measurement counter
<b>tag_out3</b>	← Percentage of valid measurements [%]
<b>tag_out4</b>	← Moving average
<b>tag_out5</b>	← Moving average
<b>tag_out6</b>	← Moving average
<b>tag_out7</b>	← Moving minimum
<b>tag_out8</b>	← Moving maximum

### Rainfall processing

<i>Attribute</i>	<i>Description</i>
<b>tag_inp1</b>	→ Acquired rainfall measurement [mm] (input)
<b>tag_out1</b>	← Cyclic counter
<b>tag_out2</b>	← Valid measurement counter
<b>tag_out3</b>	← Percentage of valid measurements [%]
<b>tag_out4</b>	← Instantaneous rainfall [mm] (current precipitation in the cycle)
<b>tag_out5</b>	← Instantaneous precipitation intensity [mm/h]

<b>tag_out6</b>	← Average precipitation intensity [mm/h]
<b>tag_out7</b>	← Minimum precipitation intensity [mm/h]
<b>tag_out8</b>	← Maximum precipitation intensity [mm/h]
<b>tag_out9</b>	← Accumulated rainfall [mm] (precipitation accumulated during the period)
<b>tag_out10</b>	← Total rainfall [mm] (total accumulated precipitation)
<b>tag_out11</b>	← Rain gauge test [mm] (rain gauge test precipitation)

### Anemometer processing (wind)

<i>Attribute</i>	<i>Description</i>
<b>param1</b>	→ Wind calm threshold [m/s] (typical = 0.5 m/s)
<b>param2</b>	→ Number of wind sectors [0, 8, 16, 36, 360]
<b>param3</b>	→ Max. angle of the dominant sector [°]
<b>param4</b>	→ Minimum rate for dominant sector [%]
<b>tag_inp1</b>	→ Instantaneous speed measurement (input)
<b>tag_inp2</b>	→ Instantaneous direction measurement (input)
<b>tag_out1</b>	← Cyclic counter
<b>tag_out2</b>	← Valid speed measurement counter
<b>tag_out3</b>	← Valid direction measurement counter
<b>tag_out4</b>	← Sum of speed values
<b>tag_out5</b>	← Sum of direction sines
<b>tag_out6</b>	← Sum of cosines in direction
<b>tag_out7</b>	← Sine vector component sum
<b>tag_out8</b>	← Sum of the cosine vector component
<b>tag_out9</b>	← AVERAGE SPEED (scalar calculation) [m/s]
<b>tag_out10</b>	← AVERAGE DIRECTION (trigonometric calculation) [°N]
<b>tag_out11</b>	← VECTOR SPEED (magnitude of resultant vector) [m/s]
<b>tag_out12</b>	← VECTOR DIRECTION (resultant vector angle) [°N]
<b>tag_out13</b>	← MINIMUM SPEED VALUE [m/s]
<b>tag_out14</b>	← MINIMUM SPEED MINUTE [Daily Minute]
<b>tag_out15</b>	← MAXIMUM SPEED VALUE [m/s]
<b>tag_out16</b>	← MINUTE OF MAXIMUM SPEED [Daily Minute]
<b>tag_out17</b>	← DIRECTION AT MAXIMUM SPEED [°N]
<b>tag_out18</b>	← SET DIRECTION AT MAXIMUM SPEED [°N]
<b>tag_out19</b>	← Prevailing sector: SECTOR DIRECTION <sup>(*)</sup> [°N]
<b>tag_out20</b>	← Dominant sector: AVERAGE INTENSITY <sup>(*)</sup> [m/s]
<b>tag_out21</b>	← Dominant sector: MAXIMUM INTENSITY VALUE <sup>(*)</sup> [m/s]
<b>tag_out22</b>	← Dominant sector: MINUTE MAXIMUM INTENSITY <sup>(*)</sup> [Daily minute]
<b>tag_out23</b>	← STANDARD DEVIATION OF SPEED [m/s]
<b>tag_out24</b>	← STANDARD DEVIATION OF DIRECTION [°N]
<b>tag_out25</b>	← LAST SPEED MEASUREMENT [m/s]
<b>tag_out26</b>	← LAST DIRECTION MEASUREMENT [°N]
<b>tag_out27</b>	← Dominant sector: INITIAL EXTREME <sup>(*)</sup> [°N]
<b>tag_out28</b>	← Dominant sector: FINAL EXTREME <sup>(*)</sup> [°N]

<sup>(\*)</sup> Values available only after processing

### Reference evapotranspiration (ET<sub>o</sub>) calculation

### Penman-Monteith FAO-56 method

<i>Attribute</i>	<i>Description</i>	<i>Notes</i>
<b>param1</b>	→ Calculation method (*)	1 = Net solar radiation, 2 = Global solar radiation
<b>param2</b>	→ Altitude [m.a.s.l.]	Elevation above sea level
<b>param3</b>	→ Latitude N/S [°deg]	Positive (North) - Negative (South)
<b>tag_inp1</b>	→ Temperature [°C]	Input measurement
<b>tag_inp2</b>	→ Humidity [%]	Input measurement
<b>tag_inp3</b>	→ Wind speed at 2 meters [m/s]	Input measurement
<b>tag_inp4</b>	→ Solar radiation [W/m <sup>2</sup> ]	Input measurement
<b>tag_out1</b>	← Evapotranspiration ET <sub>o</sub> [mm]	Output data

(\*) With net radiation sensor (Net-radiometer) or global radiation sensor (Pyranometer)

### 4.3.7 Control Section

This section is dedicated to managing **control functions**, specifically **alarms** and **commands for digital and/or analog outputs**, both to external devices and locally on the data logger.

The control functions currently available are:

- **Measurement alarm control**
- **Data rate control**
- **MODBUS output control**
- **MODBUS Data Mapping**

XML example of the controls section:

```

<CONTROLS>
  <ALARM name="Low battery" type="0" scan="10" tag_inp="0048" min="$13"... max="" ret="0" wait="0" tag... />
  <ALARM name="Door open" type="0" scan="5" tag_inp="0050" min="50" ... max="" ret="0" wait="0" tag... />
  <MODBUS name="BASE Control" type="2" id="1" com="7" baud="57600" par="N" data="8" stop="1" scan="3"...>
    <OUTPUT name="Command" addr="0" type="0" expr="$20<>0" low="-2E9" upp="+2E9" mode="0"/>
  </MODBUS>
</CONTROLS>

```

#### Alarm Control Configuration

**Alarm monitoring** of the measurement is performed periodically based on the configured scan interval. If the measurement value exceeds the respective maximum (or minimum) threshold—either rising or falling—and this condition persists for the set duration, a corresponding alarm event will be generated.

The alarm status code is stored in the assigned output location (*tag\_out*), making the information available for subsequent storage and transmission phases.

The XML element `< ALARM ... />` includes the following attributes:

- **name** – name of the control;
- **type** – type of check: 0 = MEASUREMENT ALARM
- **scan** – interval at which the check is performed (seconds);
- **shift** – interval offset (seconds);
- **tag\_inp** – location of the input tag variable (measurement or data);
- **min** – minimum alarm threshold; default: "" = none;
- **prn** – minimum pre-alarm threshold (warning); default: "" = none;
- **prx** – maximum pre-alarm threshold (warning); default: "" = none;
- **max** – maximum alarm threshold; default: "" = none;
- **ret** – return offset (hysteresis on the threshold); default = 0;
- **wait** – dwell time before alarm activation (seconds); default = 0;
- **act** – rate change activation: 0 = No, 1 = Yes
- **tag\_out** – output tag variable location (alarm status);

List of output alarm status codes:

- 2. MINIMUM ALARM
- 1. MINIMUM PRE-ALARM
0. NORMAL
1. MAXIMUM PRE-ALARM
2. MAXIMUM ALARM
3. ACQUISITION ERROR
4. MEASUREMENT OUT OF RANGE
5. MEASUREMENT DISABLED or OUT OF SERVICE

## Frequency Control Configuration

The **sampling rate control** operates by dynamically modifying the time intervals configured in the data processing and storage functions.

This adjustment is based on the system's operational status, which can be **normal**, **warning**, or **alarm**. This allows the recording frequency and subsequent data transmission to be automatically adapted.

For the control to function correctly, the following conditions must be met:

- the relevant intervals are configured and expressed in seconds;
- the intervals are specified using **parameter notation**. For example:
  - \$14 = interval in **normal state**
  - \$15 = interval in **warning state**
  - \$16 = cadence in **alarm state**

The XML element <CONTROL ... /> includes the following attributes:

- **name** – name of the control;
- **type** – type of check: 3 = SCAN CHECK (frequency change)
- **scan** – interval, expressed in seconds, at which the check is performed;
- **cad0** – frequency parameter in **normal state**;
- **cad1** – rate parameter in **warning state (pre-alarm)**;
- **cad2** – cadence parameter in **alarm state**;
- **tag\_out** – variable location of output tag (contains the cumulative alarm status);

## MODBUS Output Control Configuration

Allows writing to outputs or registers on local or remote MODBUS devices.

The XML element < MODBUS ... /> includes the following attributes:

- **name** – control name;
- **type** – control type: 2 = MODBUS OUTPUT
- **id** – hardware address of the Modbus device (Slave ID: 1–247);
- **com** – communication port to which the device is connected:
  0. LAN (TCP/IP sensor)
  1. COM1 DB9 (RS-232)
  2. COM2 RX/TX (RS-232)
  3. COM3 RX/TX (RS-232)
  4. COM4 A/B (RS-485)
  5. COM5 A/B (RS-485)
  6. COM6 A/B (RS-485)
  7. COM7 A/B (RS-485)
  8. COM8 RX/TX (RS-232)
  9. COM9 A/B (RS-485)
  10. COM2 A/B (RS-485)
- **baud** – serial communication speed: 1200, 2400, 4800, 9600, 19200, 38400, 57600, 115200 bps
- **par** – parity: N = None, E = Even, O = Odd; (default: N);
- **data** – number of data bits: 8 – 7 bits; (default: 8);
- **stop** – stop bits: 1 – 2 bits; (default: 1);
- **ip** – IP address (Modbus TCP/IP);
- **port** – port (Modbus TCP/IP);
- **scan** – scan interval (seconds);
- **timeout** – maximum response wait time (milliseconds)

## Output/Register Configuration

XML element < OUTPUT ... />

- **name** – output/register name;
- **addr** – output/register address. Identifies the MODBUS address to write to according to the standard data addressing convention:
  - (0x) 000001..065536 Function 5/15: Write Single/Multiple Coils
  - (4x) 400001..465536 Function 6/16: Write Single/Multiple Registers
- **type** – data type:
  - Output Coils: 0 = Boolean (0/1)
  - Holding Registers: 1 = Signed (16-bit), 2 = Unsigned (16-bit), 3 = Swapped Long (32-bit), 4 = Long integer (32-bit), 5 = Swapped F.P. Little-endian (CDAB), 6 = Floating-Point Big-endian (ABCD)
- **expr** – value conversion expression (to be applied to the data to be written);
- **low** – lower limit of the data's valid range;
- **upp** – upper limit of the data's valid range (*upper limit*);
- **mode** – execution mode (0 = only when the value changes, 1 = always at every interval);

## MODBUS Data Mapping Configuration

By configuring **MODBUS data mapping**, the data logger operates as a **MODBUS Slave** device, making its internal variables available via the **MODBUS RTU** protocol (over a serial line) and/or **MODBUS TCP/IP** (over an Ethernet or TCP/IP network).

Mapping allows you to define the correspondence between the data logger's internal locations (*tags*) and the MODBUS registers exposed to external devices. In this way, acquired or processed data can be made available to supervisory systems, PLCs, or other control devices.

The XML element <MODBUS-MAP ... /> defines the characteristics of the MODBUS map, specifying the following attributes:

- **name** – name of the map;
- **funct** – code of the MODBUS function being served: 1 = Coil States (1x), 2 = Input States (2x), 3 = Holding Registers (4x), 4 = Input Registers (3x)
- **addr** – starting address of the data;
- **type** – data type: 0 = Boolean (0/1), 1 = Signed (16-bit), 2 = Unsigned (16-bit), 3 = Swapped Long (32-bit), 4 = Long integer (32-bit), 5 = Swapped F.P. Little-endian (CDAB), 6 = Floating-Point Big-endian (ABCD)
- **scan** – interval at which the map is updated (seconds);

### 4.3.8 Data logging

Data is recorded in an **SQLite database** within the device's **eMMC** memory.

Depending on the configuration, one or more separate databases (archive files) may be provided.

The archive files are located in the folder:

```
/home/da20k/arc
```

Each file is named according to the following format:

```
<n>.db
```

where:

- **<n>** represents the identification number assigned to the archive;
- **.db** indicates the extension of a database file.

#### Record Type

Each archive may contain one of the following record types:

- 0 - Historical record
- **1 - Instant data record** - Instant record (\*)
- 2 - Alarm record

(\*) Note: The database for a snapshot data store is created in RAM (it is not permanently stored on the eMMC)

#### Record Format

The default standard format for data logging is the **Dynamic Record Layout** described in Section [4.3.10 – Record Layout](#).

Other recording formats may be implemented for specific applications.

#### Archive Management Mode

Data archives are managed by the data logger in **circular mode**.

Once the maximum number of records (default: 86,400) or the maximum allowed size (default: 8 MB) is reached, storage continues by progressively overwriting the oldest records.

The data retention time therefore depends on the configured recording interval. An indicative estimate of the retention time is shown in the table below.

Recording interval	Data retention
1 minute	~ 60 days
5 minutes	~ 10 months
15 minutes	~ 2 years
1 hour	~ 9 years

Example of an XML section related to data storage (STORAGES):

```

<STORAGES>
  <ARCHIVE name="Measurement Archive 1.db" file="1" type="1" format="0" maxrec="1" maxsize="1" id="" ...>
    <RECORD name="Instantaneous Records" scan="10" shift="0">
      <WRITE name="TA ist" id="1" type="A" tag="0030" unit="°C" dec="1"/>
      <WRITE name="RH ist" id="2" type="A" tag="0032" unit="%" dec="0"/>
      <WRITE name="PLUV sum" id="3" type="A" tag="0108" unit="mm" dec="1"/>
    /RECORD>
  </ARCHIVE>
  <ARCHIVE name="Data Archive 6.db" file="6" type="0" format="0" maxrec="86400" maxsize="16" id="" ...>
    <RECORD name="Historical records 5" scan="300" shift="0">
      <WRITE name="PLUV sum" id="3" type="B" tag="0108" unit="mm" dec="1"/>
    </RECORD>
    <RECORD name="Historical Records 30" scan="1800" shift="0">
      <WRITE name="TA avg" id="1" type="B" tag="0160" unit="°C" dec="1"/>
      <WRITE name="TA min" id="1" type="C" tag="0161" unit="°C" dec="1"/>
      <WRITE name="TA max" id="1" type="D" tag="0163" unit="°C" dec="1"/>
      <WRITE name="TA dev" id="1" type="F" tag="0166" unit="°C" dec="6"/>
      <WRITE name="RH avg" id="2" type="B" tag="0174" unit="%" dec="0"/>
      <WRITE name="RH min" id="2" type="C" tag="0175" unit="%" dec="0"/>
      <WRITE name="RH max" id="2" type="D" tag="0177" unit="%" dec="0"/>
      <WRITE name="RH dev" id="2" type="F" tag="0180" unit="%" dec="6"/>
    </RECORD>
  </ARCHIVE>
</STORAGES>

```

## Archive configuration

The XML element < ARCHIVE ... /> includes the following attributes:

- **name** – archive name;
- **file** – archive file number (example: specifying 6 will create the database file “6.db”);
- **type** – record type:
  0. **Historical record** (HISTORICAL data record)
  1. **Instant record** (INSTANT data log)
  2. **Alarm record** (ALARM data)
- **format** – record format:
  0. **Standard Micros Dynamic Data** (Dynamic Record Format)
    1. <reserved for future use>
    2. <reserved for future use>
    3. <reserved for future use>
    4. **XML MeteoContext** (specific to Kyrgyzstan control units)
- **maxrec** – maximum number of records (default: 86,400);
- **maxsize** – maximum database file size (default: 8 MB);
- **id** – (optional) alternative storage identifier (if different from the general station ID);
- **merge** – option to merge records with the same time (not in use);
- **backup** – enables/disables data backup to external storage devices;

## Record configuration

The XML element < RECORD ... /> contains the following attributes:

- **name** – record name;
- **scan** – interval in seconds at which recording is performed <sup>(1)</sup> ;
- **shift** – interval offset (to delay or advance the recording time (seconds));

<sup>(1)</sup> Alarms are recorded only for events that have not yet been recorded when the configured interval expires.

### Data field configuration: <WRITE .../>

- **name** – data name;
- **id** – sensor identifier (measurement ID);
- **type** – data attribute;
- **tag** – memory location;
- **unit** – unit of measurement;
- **dec** – number of decimal places used to format the value;

<sup>(2)</sup> Letter identifying the type of statistical data (Dynamic Record Trace):

- 'A' = Instantaneous value
- 'B' = Average value
- 'C' = Minimum value
- 'D' = Maximum value
- 'E' = Count
- 'F' = Standard deviation
- 'G' = Variance
- 'H' = Sum
- 'I' = Invalidation percentage
- 'L' = Minimum
- 'M' = Minute of the maximum
- 'R' = Error code
- 'J' = Diagnostic status

## Hold memory configuration

This function creates a copy in RAM of the most recently stored data. This feature is useful for reducing response times to real-time data request commands (data cache).

XML example:

```
<RETAIN name="Memory retention" file="6" scan="1800" shift="0"/>
```

Configuration:

- **name** – function name;
- **file** – archive file number (to which retention applies);
- **scan** – interval in seconds corresponding to the data retention period;
- **shift** – interval offset to delay or advance storage (seconds);

### 4.3.9 Data Backup

---

Data records stored in archive files can also be enabled for **backup copying** to external storage media, such as **SD Memory Cards** and/or **USB Flash Drives**.

In this case, the storage medium will be managed in sequential mode, with data written progressively until all available space is used up.

The backup feature must be enabled in advance in the initialization file by selecting the storage device to be used.

The primary backup drive is the **SD card**, mounted at the following default path:

```
/mnt/sd/backup/data
```

As an alternative or in addition to the SD card, you can also use a **USB flash** drive as a secondary drive, mounted at the following path:

```
/mnt/usb/backup/data
```

#### Backup Folder Structure

The backup folder path is automatically organized into **subfolders** that identify:

1. the data archive number
2. the year of recording

Example:

```
/mnt/sd/backup/data/6/2024
```

This path identifies the folder containing the backups of data archive no. 6 for the year 2024.

#### Backup file names

Data is copied into **daily files**, named according to the following format:

```
YYYYMMDD.dat
```

where:

- **YYYY** = year
- **MM** = month
- **DD** = day

Example:

```
20240101.dat  
20240102.dat  
20240103.dat
```

---

## Replacing the storage medium

SD Memory Cards and USB Flash Drives can be **removed and replaced even while the data logger is running**.

To ensure compatibility between **Linux** and **Windows** operating systems, the devices must be formatted with **the FAT32 file system**.

---

### 4.3.10 Record Format

---

The data recorded in the data logger's archives is natively formatted according to the SIAP+MICROS standard defined **as Dynamic Record Format**.

The **Dynamic Record Header** contains information regarding the originating station (archive ID), the date and time of the recording, and the type of data stored.

The recording date and time constitute the record's timestamp, which always refers to the end of the processing period.

In *dynamically structured* record traces, the length of the trace varies depending on the number and type of data contained. Therefore, in situations where the data to be included in the trace is minimal, the length of the trace itself—and consequently the space occupied by the data—will be limited.

The dynamic record is suitable for containing current instantaneous data, statistical data obtained from processing functions, and alarm records.

The record consists of three distinct parts named respectively:

**HEADER**

**BODY**

**TERMINATOR**

Each of these parts is internally divided into fields separated by the character “,” (ASCII 44). All data managed by the system is recorded in the control unit's internal memory (NAND Flash) and, if a backup configuration is present, also on an external storage medium (SD Memory card).

Depending on the type of data, recording is performed in distinct memory areas. The division into areas is dictated, as described below, by specific storage requirements.

The data is stored in the corresponding memory area and is written as sequences of recognizable ASCII characters. The storage methods depend on the specific type of *data* in question. These methods are described by *the Record Layouts* that define their structure. Three different storage methods have been implemented, one for each type of *data*.

The record types are:

- **Statistical Data Record Format**
- **Instantaneous Data Record Format**
- **Alarm Data Record Format**

For a detailed description of the SIAP+MICROS record layouts, refer to the **s011-d Dynamic Records** manual.

### 4.3.11 | Data Transmission

The data logger can be configured to transmit the following types of data via various communication modes and protocols:

- **Historical Data**
- **Alarms**
- **Images** (e.g., captured by a **webcam**)

The available transmission methods depend on the system configuration and the enabled communication interfaces (e.g., **cellular modem**, **radio-frequency modem**, **satellite transmitter**, etc.).

The settings related to data transmission are defined in the **<TRANSMISSIONS>** section of the configuration file, where you can specify the protocols used, the addresses of the destination servers, and the conditions for sending data.

This section describes the various supported transmission methods and their configuration parameters.

#### FTP Transmission

The data logger's main file transmission function is based on the following protocols:

- **FTP (File Transfer Protocol)**
- **SFTP (SSH File Transfer Protocol)**

The FTP function uses a dedicated background process that retrieves the files to be transferred from a local source folder. The files to be transmitted are prepared by extracting the data not yet sent from the archive and assigning them a name already formatted for the destination system.

To speed up and make the transfer process more reliable, each file has a predefined maximum size (*pack*).

Data files are prepared according to the configured scan interval. In the event of a communication interruption, the system automatically manages the recovery of unsent data by increasing the scan frequency (up to a maximum of 1 minute).

To transfer images from a webcam or other local files, you must specify the path of the source file to be sent. The function will then move and rename the file within the local directory structure before sending.

To further reduce the size of the transmitted files, data compression can be enabled, provided that the destination system supports the corresponding decompression.

Local files are automatically deleted only after confirmation that the transfer has been completed.

Example of an XML configuration for FTP transmission:

```

<TRANSMISSIONS>
  <FTP name="Transfer" type="0" host="95.110.175.7" port="21" ssl="0" user="gigasum" pass="*****" dir="" tag="...>
    <PUT name="Send Alarms" scan="60" shift="0" source="4.db" ... target="ST%iii_ALARM.. .dat." dir="/Data"/>
    <PUT name="Send historical data" scan="$14" shift="0" source="6.db" ... target="ST%iii_DATA... .dat"
dir="/..."/>
  </FTP>
</TRANSMISSIONS>

```

#### FTP Transmission Configuration

The XML element **< FTP ... />** includes the following attributes:

- **name** – transmission name;
- **type** – protocol: 0 = FTP (File Transfer Protocol), 1 = SFTP (SSH File Transfer Protocol)
- **host** – hostname or IP address of the server;
- **port** – server port (default: 21);
- **ssl** – data encryption: 0=None, 1=SSL/TLS if available, 2=Explicit SSL/TLS, 3=Implicit SSL;
- **user** – username (account);
- **pwd** – encrypted login password;
- **dir** – remote directory (destination for upload or source for download);
- **tag** – variable location of output tag (transfer result);

#### File upload configuration:

Attributes of the XML element **<PUT .../>**

- **name** – upload name;
- **scan** – session interval used to prepare the copy of the file to be sent (seconds);
- **shift** – interval offset;
- **source** – number or name of the archive from which to retrieve data (e.g., 6.db) or path to a source file to be copied (e.g., /home/da20k/image/current.jpg);
- **pack** – maximum size of the data packet to be sent (default: 64 KB);
- **format** – transcoding / export of the record track:
  0. **Native** (no transcoding);
  1. **Normalized** (Dynamic Record Trace with normalized date/time);
  2. **CSV Report (wide table)**;
  3. **CSV Export (long list)**;
  4. **XML (MeteoContext)**;
  8. **OTT MIS (ASCII)**;
- **header** – header rows for CSV Report (optional);
- **dtfmt** – date and time format for CSV Report/Export (Default: ISO 8601 Standard);
- **delim** – delimiter for CSV reports/exports: 0=Europe, 1=EN/USA, 2=Tab;
- **sensor** – Sensor offset for CSV export (optional for SIRT encoding - CFR Tuscany);
- **period** – Export frequency: 0=None, 1=Hourly, 2=Daily, 3=Monthly;
- **cpr** – file compression (default: 0=No);
- **mode** – Write mode: 0=Overwrite (default), 1=Append;
- **target** – name of the remote destination file <sup>(\*)</sup> ;
- **dir** – Remote destination directory (optional) if different from the one specified at the higher level;

#### File reception (download) configuration:

Attributes of the XML element **<GET .../>**

- **name** – download name;
- **scan** – session interval used to search for the file to download (seconds);
- **shift** – interval offset;
- **source** – name of the source file to download (e.g., cnf.xml);

- **target** – name of the local destination file (default: = source);
- **dir** – remote download directory (optional) if different from the one specified at the higher level;
- **action** – action to perform upon completion of the transfer: 0=None, 1=Restart software.

(\*) The filename can be formatted using the following placeholder characters:

- %iii                                    Station storage ID
- %yyyy%mm%dd                    Current year, month, and day
- %hh%nn%ss                        Current hour, minute, and second

Example:

```
ST%iii_DATE_%yyyy%mm%dd%hh%nn%ss.dat
```

## GOES / METEOSAT Satellite Transmission

The data logger is capable of transmitting data via **GOES** or **METEOSAT** satellite systems, using a compatible transmitter connected to the device's serial port.

The system allows for the periodic transmission of **historical data (Timed Buffer)** or the immediate transmission of **alarm events (Random Buffer)**, according to the channels and modes assigned by the satellite operator.

For timed transmission, synchronization of the data logger's clock is essential, which is performed via the GPS receiver integrated into the transmitter.

### Satellite Transmission Configuration

The XML element **< SATELLITE ... />** includes the following attributes:

- **name** – transmission name;
- **type** – satellite type:
  - 0 = GOES
  - 1 = METEOSAT
- **mode** – transmitter model used:
  - 1 = Microcom GTX-1.0
  - 2 = Microcom GTX-2.0
  - 3 = WaterLOG H-2221
- **com** – communication port to which the transmitter is connected:
  - 1 = COM1 RS-232
  - 4 = COM4 RS-232
- **baud** – serial communication speed (bps):
  - 1200, 2400, 4800, 9600, 19200, 38400, 57600, 115200 (default: 9600)
- **scan** – interval in seconds at which date/time synchronization with the GPS receiver is performed;
- **shift** – synchronization interval offset, used to advance or delay the clock update (default: -120 sec.);

## Data or Alarm Transmission Configuration

The XML element **<SEND ... />** defines the parameters for transmitting data or alarms.

Available attributes:

- **name** – transmission name;
- **scan** – transmission interval (seconds);
- **shift** – transmission interval offset (seconds);
- **file** – the number of the archive from which to retrieve data or alarms (e.g., 6.db or 4.db);
- **type** – transmission buffer type:
  - 0 = Timed Transmit Buffer (Historical Data)
  - 1 = Random Transmit Buffer (Alarms)
- **format** – data encoding format:
  - 0 = Native
  - 1 = Pseudo-binary (6-bit encoding)
- **fact** – Multiplication factor applied to values:
  - 0 = Automatic
  - 10, 100, 1000 = scaling factors
- **pack** – number of packets to retransmit to ensure historical data redundancy (0 = current packet only);

## Iridium SBD Satellite Transmission

**Iridium SBD (Short Burst Data)** satellite transmission allows the data logger to send and receive short data messages via the **Iridium** satellite network using a compatible transceiver module.

The **SBD** system is designed for telemetry and remote monitoring applications where it is necessary to reliably transmit small amounts of data even in the absence of terrestrial network coverage. Data is sent in the form of **short binary packets**, which are routed through the Iridium satellite constellation to a data collection server.

Communication takes place via a **satellite uplink session**, during which the data logger can:

- **transmit data or alarms** (to the collection center);
- **receive any incoming messages** (commands for the data logger).

Each SBD session establishes a temporary connection with the Iridium satellite network, enabling the exchange of messages between the device and the destination system.

## Iridium Transceiver Session Configuration

The XML element **<IRIDIUM ... />** defines the parameters of the communication session.

The available attributes are:

- **name** – session name;
- **scan** – interval of the periodic retransmission session (seconds);
- **enab** – transmission activation condition:
  - 0 = Send disabled
  - 1 = Sending enabled (default)

- **mode** – mode for receiving incoming messages:
  - 0 = Default: only if there are messages to send
  - 1 = Always: at every session
- **com** – communication port to which the transmitter is connected:
  - 1 = COM1 RS-232
  - 4 = COM4 RS-232
- **baud** – serial communication speed (bps):
  - 1200, 2400, 4800, 9600, 19200, 38400, 57600, 115200 (default: 19200)

### Data or alarm transmission configuration

The XML element **<SEND ... />** defines the parameters for transmitting data or alarms.

Available attributes:

- **name** – transmission name;
- **scan** – transmission interval (\*) expressed in seconds;
- **shift** – transmission interval offset (seconds);
- **file** – number of the archive from which to retrieve data or alarms (example: 6.db or 4.db);
- **type** – record type:
  - 0 = Historical
  - 1 = Alarm
- **format** – data encoding format:
  - 0 = Native
  - 1 = Pseudo-binary (6-bit encoding)
- **fact** – Multiplication factor applied to values:
  - 0 = Automatic
  - 10, 100, 1000 = scaling factors
- **wait** – waiting time for retaining historical data before transmission is activated (seconds);

(\*) The transmission interval for sending historical records must coincide with the data packet formation interval in accordance with the transcoding defined at the collection center. For alarms, however, it represents the scan interval used to check for the presence and transmission of a new alarm record.

### 4.3.12 Display

---

In this section, the user defines the list of measurements to be displayed (see section [4.2.4 – Current Measurements](#)). The display order corresponds to the order in which the items are entered in the configuration section.

The information displayed is updated at a scan interval, normally set to 3 seconds.

Example of XML configuration for display:

```
<DISPLAY scan="3">
  <ROW name="TA" text="Air temperature" tag="0030" unit="°C" dec="1"/>
  <ROW name="RH" text="Relative Humidity" tag="0032" unit="%" dec="0"/>
  <ROW name="PLUV" text="Precipitation" tag="0108" unit="mm" dec="1"/>
  <ROW name="LIV" text="Water level" tag="0036" unit="m" dec="2"/>
  <ROW name="VBAT" text="Battery" tag="0048" unit="V" dec="1"/>
</DISPLAY>
```

#### Display row configuration

Each row displayed on the screen is defined using the XML element `<ROW ... />`, which includes the following attributes:

- **name** – element name;
- **text** – displayed text (label);
- **tag** – variable location (tag) of the data to be displayed;
- **unit** – associated unit of measurement.
- **dec** – number of decimal places (for value formatting).

### 4.3.13 Variables, e , and operators

The following tables list the variables and operators that can be used in configuration expressions.

#### Parameters and variables (tags)

<b>\$id</b>	Value of the parameter with <b>ID</b> (e.g., \$11 = value of parameter 11)
<b>Mi</b>	Value of the variable at memory location <b>i</b> (e.g., M1 = value of location 1) If the variable takes the value -9999, it indicates invalid data. Note: M0 indicates the raw data of the current measurement just acquired.
<b>Vi</b>	Validation status of memory variable <b>i</b> (e.g., V1 = validation status of variable M1). 1 = Valid data 0 = Invalid data.
<b>Qi</b>	Quality code of memory variable <b>i</b> (e.g., Q1 = quality code of variable M1). 1 = Valid data 3 = Acquisition error 4 = Value out of range 5 = Out of service or disabled

#### Arithmetic operators

<b>+</b>	Addition
<b>-</b>	Subtraction
<b>/</b>	Division
<b>*</b>	Multiplication
<b>^</b>	Exponentiation
<b>MOD</b>	Remainder of division

#### Logical operators

<b>NOT</b>	Logical negation (equivalent operator: !)
<b>AND</b>	Logical conjunction
<b>OR</b>	Logical disjunction

#### Comparison operators

<b>=</b>	Equal
<b>&gt;</b>	Greater than
<b>&gt;=</b>	Greater than or equal to
<b>&lt;</b>	Less than
<b>&lt;=</b>	Less than or equal to
<b>&lt;&gt;</b>	Not equal

#### Bitwise comparison operators

<b>&amp;</b>	Bitwise AND
<b> </b>	Bitwise inclusive OR

### Boolean constants

<b>FALSE</b>	Equivalent to the value <b>0</b>
<b>OFF</b>	
<b>TRUE</b>	Equivalent to the value <b>1</b>
<b>ON</b>	

### Mathematical functions

<b>ABS</b>	Absolute value of a number
<b>ATN</b>	Arctangent of a number
<b>COS</b>	Cosine of an angle
<b>EXP</b>	Exponent of the base of the natural logarithm <i>and</i>
<b>INT</b>	Integer part of a number
<b>LIM</b>	Maximum or minimum value of a number between two limits
<b>LN</b>	Natural logarithm of a number
<b>LOG</b>	Common logarithm of a number
<b>MAX</b>	The greater of two numbers
<b>MIN</b>	Minimum value between two numbers
<b>SGN</b>	Sign of a number
<b>SIN</b>	Sine of an angle
<b>SQR</b>	Square root of a number
<b>TAN</b>	Tangent of an angle

## 4.4 Command interpretation

Via the Modbus RTU / TCP/IP input communication protocol, the data logger implements *User-Defined* Function No. 65, which allows for the transmission of a set of specific commands (*Siap+Micros* command set).

The following section provides a description of the function and a complete list of commands supported by the data logger.

### 4.4.1 Modbus Protocol Specification

User-Defined Modbus function code **65 (0x41) - SIAP+MICROS commands**

#### Request:

Field	Size	Value range
Slave ID	1 Byte	0x00 to 0xF7, 0xFF
Function code	1 Byte	0x41
Bytes count	2 Bytes	0x0000 to 0xFFFF ( <i>N</i> )
Data request	<i>N</i> Bytes	0x00 to 0xFF
CRC-16	2 Bytes	0x00 to 0xFF

#### Valid response:

Field	Size	Range value
Slave ID	1 Byte	0x00 to 0xF7, 0xFF
Function code	1 Byte	0x41
Bytes count	2 Bytes	0x0000 to 0xFFFF ( <i>N</i> )
Response data	<i>N</i> Bytes	0x00 to 0xFF
CRC-16	2 Bytes	0x00 to 0xFF

#### Error response:

Field	Size	Range value
Slave ID	1 Byte	0x00 to 0xF7, 0xFF
Error code	1 Byte	0xC1
Exception code	1 Byte	0x01, 0x02, 0x03, 0x04
CRC-16	2 Bytes	0x00 to 0xFF

The following paragraphs describe the command syntax.

Note:

If commands are not sent correctly, the data logger will respond with:

- ?<*command name*>           for an unrecognized command
- 1                               for incorrect parameters

## 4.4.2 General commands

---

### Communication identifier <device-id>

Read command:       **R IDSTAZ**  
 Response:            IDSTAZ <device-id>  
  
 Write command<sup>(\*)</sup>:   **W IDSTAZ=<device-id>**  
 Response:            IDSTAZ <device-id>

### Storage ID <storage-id>

Read command:       **R ID\_MEM**  
 Response:            ID\_MEM <storage-id>  
  
 Write command<sup>(\*)</sup>:   **W ID\_MEM=<storage-id>**  
 Response:            ID\_MEM <storage-id>

<sup>(\*)</sup> Note: For the configuration commands to take effect, the data logger application must be restarted.

### System Clock and RTC

The write command will set both the system clock and the RTC clock:

Read command:       **CLK**  
 Response:            <hh> <nn> <ss> <dd> <mm> <yyyy>  
  
 Read command:       **RTC**  
 Response:            <hh> <nn> <ss> <dd> <mm> <yyyy>  
  
 Write command:       **CLK <hh> <nn> <ss> <dd> <mm> <yy[yy]>**  
 Response:            <hh> <nn> <ss> <dd> <mm> <yyyy>

### Firmware version (DA20K application)

Read command:       **!FW**  
 Response:            DA20K ver. <x>.<y>.<z>

### Reset data logger (software restart)

Command:            **RESET MICROS**  
 Response:            RESET MICROS

### Reboot data logger (hardware restart)

Command:            **!TW**  
 Response:            Terminating Watchdog

### 4.4.3 , variable ( ), and parameter management

---

#### Variable locations (memory tags)

The read command requests the values of  $\langle n \rangle$  locations starting from the starting address  $\langle index \rangle$ . The write command sets the values of  $\langle n \rangle$  locations by specifying the index and value for each one.

Read command:        **!IM  $\langle n \rangle$   $\langle index \rangle$**   
 Response:              $\langle val1 \rangle$   $\langle val2 \rangle$  ...  $\langle valn \rangle$   
  
 Write command:       **!WA  $\langle n \rangle$   $\langle index1 \rangle$   $\langle val1 \rangle$   $\langle index2 \rangle$   $\langle val2 \rangle$ ...  $\langle indexn \rangle$   $\langle valn \rangle$**   
 Response:             no response

#### User parameter (identifier: $\langle id \rangle$ )

Read command:        **!RP  $\langle id \rangle$**   
 Response:              $\langle value \rangle$   
  
 Write command:       **!WP  $\langle id \rangle$   $\langle value \rangle$**   
 Response:              $\langle value \rangle$

### 4.4.4 Archive Management

---

Specify the archive number with:  $\langle file \rangle$

#### Size (KB)

Command:        **R\_FILE $\langle file \rangle$**   
 Response:        \_**FILE $\langle file \rangle$   $\langle size \rangle$**

#### Free space (KB)

Command:        **!FR  $\langle file \rangle$**   
 Response:         $\langle bytes free \rangle$

#### Used space (KB)

Command:        **!MR  $\langle file \rangle$**   
 Response:         $\langle bytes used \rangle$

#### Sequential Data Read (Read Data)

The command reads the data and temporarily moves the user's read pointer. Specify in the following order: archive number  $\langle file \rangle$ , user  $\langle user \rangle$ , number of packets to read  $\langle pack \rangle$

Command:        **!RD  $\langle file \rangle$   $\langle user \rangle$   $\langle pack \rangle$**   
 Response:         $\langle data records \rangle$

### Confirm data read (*Read Set*)

The command aligns the read pointer with the temporary pointer. Specify: archive number *<file>*, user *<user>*

Command: **!RS *<file>* *<user>***  
Response: *no response*

### Data Read Restore

The command moves the read pointer immediately after the write pointer so that the entire file can be read again. Specify: archive number *<file>* and user *<user>*

Command: **!RE *<file>* *<user>***  
Response: *no response*

### Data Erasure (*Scratch*)

The command resets the read and write pointers so that the archive can be rewritten from the beginning:

Command: **!SC *<file>***  
Response: *no response*

### Point Reading (\*)

Specify the year, month, day, hour, minute, and second of the record where you want to position the read pointer. The response will contain the number of bytes to read:

Command: **!PR *<file>* *<yyyy>* *<mm>* *<dd>* *<hh>* *<nn>* *<ss>***  
Response: *<bytes to read>*

(\*) Note: This command repositions the read pointer for all users.

### Write data (\*)

The command writes to the specified data archive (file no. 1–253):

Command: **!WR *<file>* *<data to write>***  
Response: *no response*

(\*) Obsolete command. Use the !WRB command instead

### Writing data with a pointer

The command writes to the specified data archive (file no. 1–253) or to a system default file using a write start pointer. Normally used for writing the following system files: 0 = Configuration file (cnf.xml), 254 = Settings file (ini.xml), 255 = Application firmware (da20k):

Command: **!WRB *<file>* *<pointer>* *<data to write>***  
Response: *no response*

### Request latest data

The command returns the data from the most recent recording or from the most recent recordings within a preconfigured retention period (retention interval).

For example, with a retention interval preconfigured to 30 minutes, if a request is sent between 08:30 and 08:59, the response will contain records from 08:01 to 08:30 inclusive. If the same request is sent after 9:00 AM, the records received will cover the period from 8:31 AM to 9:00 AM inclusive. If the retention period is not configured, the response will contain only the most recent record.

**The** request message must specify the archive from which you want to read the data (*file*).

Syntax:

Command	<b>!LTR   !LBR   !LKR   !LXR</b> <i>file [yyyy mm dd hh nn ss]</i>
Response	<Data trace> <sup>(1)</sup>

The command can also synchronize the data logger's clock if date and time settings are specified. The optional parameters are: *yyyy* (year), *mm* (month), *dd* (day), *hh* (hour), *nn* (minutes), and *ss* (seconds).

Note: Clock synchronization will only be performed if the current datalogger setting differs by between  $\pm 3$  sec. and  $\pm 50$  min.

### Request historical data

This command can be used to request/retrieve data records recorded within a specific historical range. If available, all records prior to the requested time within the preconfigured retention period (including the record specified in the request) will be sent.

For example, with a retention interval set to 30 minutes, data up to 30 minutes prior will be returned. To retrieve data from 00:31 to 01:00, the request must be sent specifying 01:00:00.

If the retention period is not configured, the response will contain only the requested record.

In the request message, you must specify not only the archive from which you want to read the data (*file*), but also the date and time of the recording: *yyyy* (year), *mm* (month), *dd* (day), *hh* (hour), *nn* (minutes), and *ss* (seconds).

Syntax:

Command	<b>!DTR   !DBR   !DKR   !DXR</b> <i>file yyyy mm dd hh nn ss</i>
Response	<Data format> <sup>(1)</sup>

<sup>(1)</sup> The format of the data record received in response depends on the type of command sent:

<b>!LTR</b> ( <i>Last Text Records</i> )	Standard dynamic record (ASCII)
<b>!DTR</b> ( <i>Data Text Records</i> )	
<b>!LBR</b> ( <i>Last Binary Records</i> )	Standard binary record
<b>!DBR</b> ( <i>Data Binary Records</i> )	
<b>!LKR</b> ( <i>Last Compressed Binary Records</i> )	Compressed binary track
<b>!DKR</b> ( <i>Data Compressed Binary Records</i> )	
<b>!LXR</b> ( <i>Last eXtra Binary Records</i> )	Compressed binary track with diagnostics
<b>!DXR</b> ( <i>Data eXtra Binary Records</i> )	

## 4.4.5 Output commands

Digital outputs DIG OUT OD1 to OD8, 12V (base board)

Command: **!OD<n> <act>**  
Response: **OD<n> ON/OFF**

Activation values <act>:

0: OFF

1: ON

Outputs <n>: 0 to 8

Example commands:

**!OD1 ON** // Activates digital output OD1

**!OD1 OFF** // Turns off digital output OD1

**!12V ON** // Turn on the 12V-

**!12V OFF** // Disables the 12V-powered output

#### **Analog outputs CH10 OA1 and CH16 OA2 (base board)**

Command: **!OA<n> <val>**  
Response: **OA<n> <val>**

Setting values <val>: [millivolts]

Outputs <n>: 1 to 2

Example commands:

**!OA1 1000** // Sets analog output OA1 to 1 V

**!OA1 0** // Resets analog output OA1 to 0 V

## 5 Revision History

---

The following table lists the changes made to this document.

<b>Version</b>	<b>Date</b>	<b>Updates</b>
01	04/08/2026	<i>First version of the document</i>

All information contained in this document is current as of the time of printing. Siap+Micros S.p.A. reserves the right to change the specifications without prior notice.