

Particolari ingranditi della piastra saldata /  
magnified details of welded plate

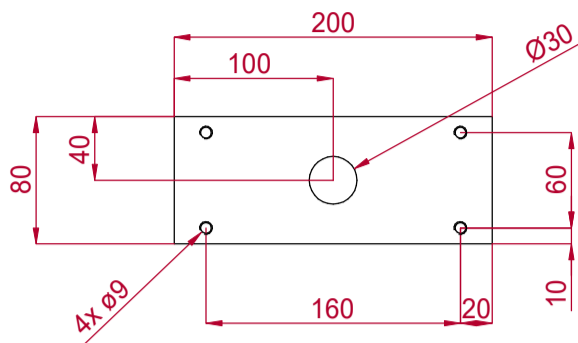

Particolari ingranditi di p099-05 /  
magnified details of p099-05

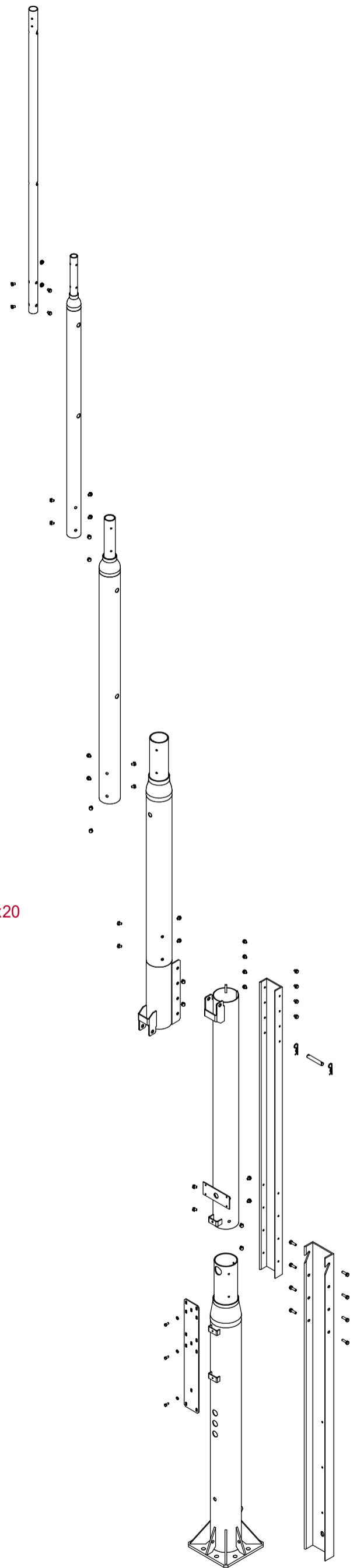
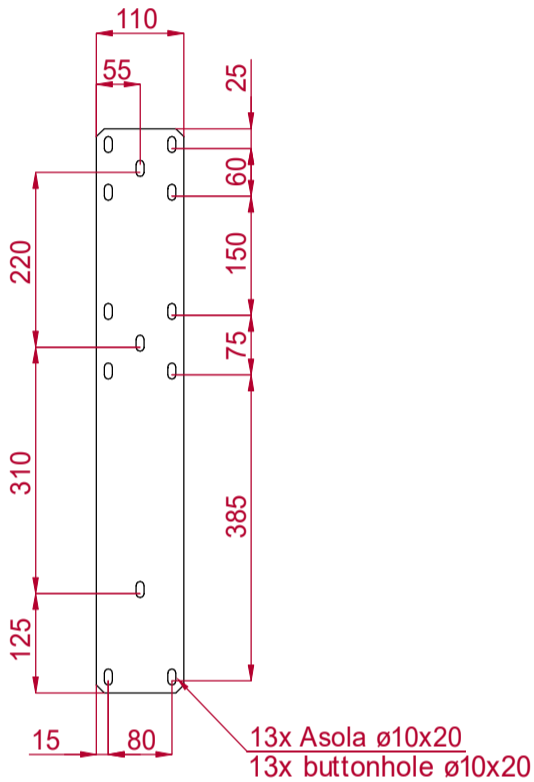

Esploso particolari palo /  
Exploded view mast's items

Codice / Code	<b>p114</b>	Nome / Name	<b>PALB10</b>	Foglio / Sheet	A3
Descrizione / Description	Palo da 10 metri 10 meters pole			Scala / Scale	1:16
Materiale / Material	Acciaio zincato / Galvanized steel			U.M.	mm
Peso / Weight	~ 175 Kg			Foglio / Sheet	1 / 1
				COOIDE / DISEGNO	Nome File
					p114-dwc

