

t011d TBAR

Digital Barometer



SIAP+MICROS

User Manual and maintenance

Summary

1	Introduction	3
2	Technical specifications	4
3	Installation and maintenance	5
3.1	Installation.....	5
3.2	Maintenance	5
4	Electric connection.....	6
4.1	Connector output	6
4.2	Connection cable.....	6
4.3	Data reading in serial (RS485 Modbus)	6
4.3.1	RS485 Modbus mode	6
5	Generic information	7
5.1	Safety.....	7
5.2	Appropriate use of the equipment	8
5.3	Storage	8
5.4	Moving	8
5.5	Disposal information	8
6	Revision history	9
7	Declaration of Conformity	10

1 Introduction

TBAR-IVS is a sensor for the measurement of atmospheric pressure which can be used for the most common meteorological applications, thanks to its good performance in terms of accuracy and sensitivity. TBAR-IVS is equipped with a piezoresistive electronic transducer with linear output. An internal electronic system compensates automatically the variation in temperature, ensuring a high precision over the whole measurement range. The transducer is based on a micro-processor chip that executes many functions. Mainly it performs assuring for instance the correct control functioning, or data pre-processing and electrical signal A/D conversion. TBAR-IVS is housed into an IP-65 box that guarantees a proper functioning of the sensor in outdoor installations, even in harsh environmental conditions. The sensor is supplied with power and signal cable (4m).

Ordering codes:

RS485 Modbus output: t011d-TBAR-IVS

2 Technical specifications

Measurement performance			
Measurement range	700 ÷ 1100		
Accuracy (RS485-ModBus)	0.4 (-15 ÷50°C)		
Accuracy (I/V output)	0.9 (-15 ÷50°C)		
Resolution	0.1		
Operating conditions			
Temperature	-30 ÷ +60 °C		
Humidity	0 ÷ 100 RH%		
Outputs			
Current	4 ÷ 20 mA ↔ 700 ÷ 1100 hPa		
Tension	0 ÷ 2 V ↔ -700 ÷1100 hPa		
RS485 MODBUS	Pression hPa		
Power supply and Consumption			
Voltage supply	7 ÷ 30 Vdc		
Power consumption	Min	Typical	Max
	4 ÷ 20 mA	5	25
	0 ÷2 V / RS485 MODBUS	1	3
Mechanical specifications			
Protective body	Plastic material IP-65 and stainless steel screws		
Electrical connections	7 male poles IP67		

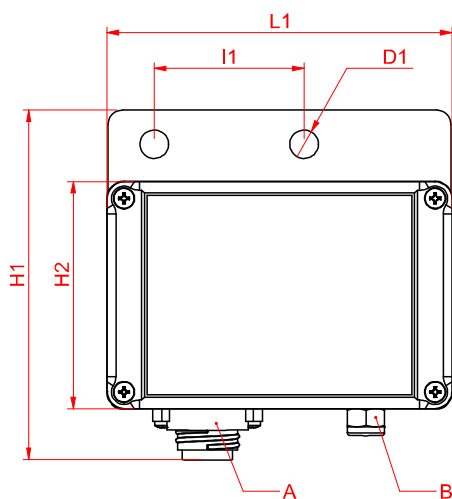

Dimension:

L1 – length: 120 mm

H1 – maximum height: 122 mm

P1 – maximum depth: 62 mm

H2 - container height: 80 mm

D1 - fixing holes diameter: 10 mm

I1 - distance between fixing holes: 52mm

Element:

A connector

B – pressure compensator

C – fixing bracke

Weight: 350 g

3 **Installation and maintenance**

3.1 **Installation**

For correct installation, the monitoring station should be placed at a distance from the closest obstacle (pylons, trees, buildings) equal to 10 times the height of the obstacle itself.

Normally, according to WMO standards, the installation height of the sensor must be between 1.25 and 2 meters.

The sensor is provided with a fixing bracket with 2 holes with a 52mm center distance. As highlighted in the image below, the sensor can be fixed without distinction in any position of the Siap+Micros standard support bracket using 2 bolts.

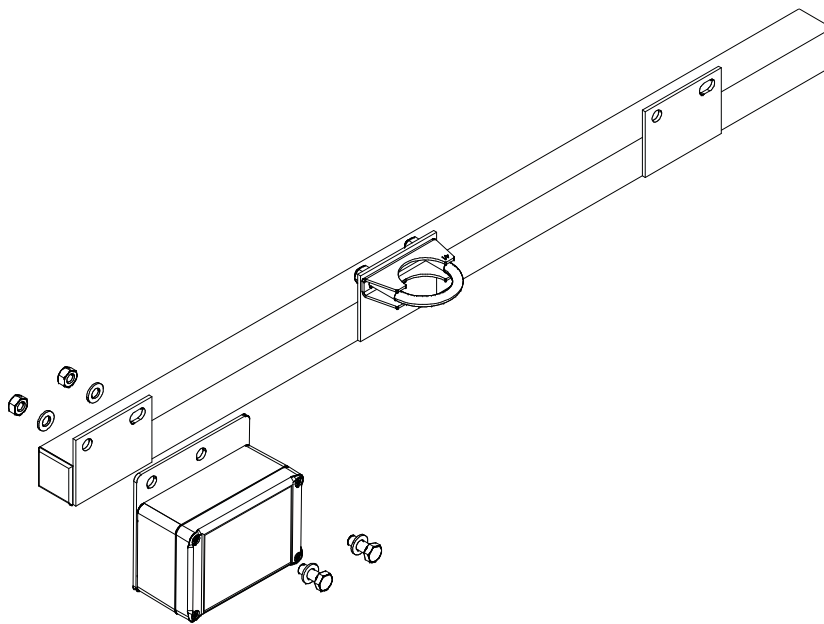

3.2 **Maintenance**

This type of transducer does not require particular maintenance operations, it is advisable to periodically check the factory calibration with sample instruments

4 Electric connection

4.1 Connector output

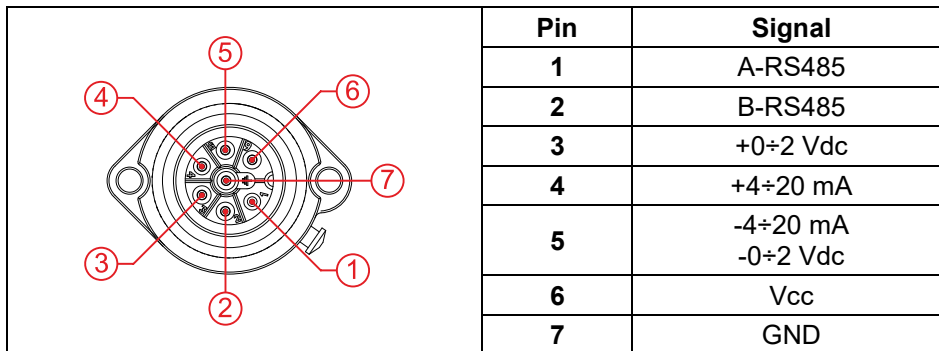

4.2 Connection cable

The connection cables supplied with the sensors are made with circular connectors with housing, 8 x 22 mmq cable, shielded and ferrules for connection to the data logger terminals. The braid is connected to the general ground lead.

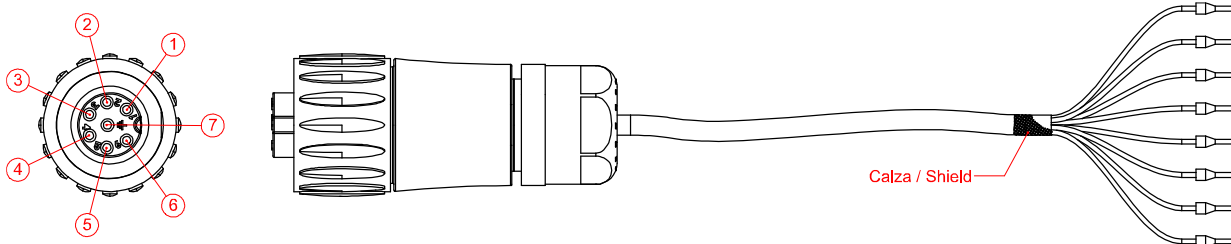

Pin	1	2	3	4	5	6	7	7
Cable	Red	White	Green	Black	Orange	Yellow	Blu	Brown
Signal	A-RS485	B-RS485	+0÷2 Vdc	+4÷20 mA	-0÷2 Vdc -4÷20 mA	Vcc	GND	GND

4.3 Data reading in serial (RS485 Modbus)

Sensors with RS485 Modbus or SDI-12 output send data only upon specific request from the PC, data logger or PLC.

Below are the correct communication parameters of the device performing the interrogation.

4.3.1 RS485 Modbus mode

Serial port settings: 9600 baud, no parity, 8 data bit, 1 bit di stop.

Compatible with ModBus RTU protocol, functions supported: "03 – read Holding Registers" e "04 – Read Input Registers".

Data type: "2 registers swapped float IEEE 754 in the form CDAB where A is the most significant byte of the float and D is the less significant byte of the float (swapped float)".

ID	Registers	Units	Reg. 1-2	Reg. 3-4	Reg. 5-6	Reg. 7-8	Reg. 9-10	Reg. 11-12	Reg. 13-14
5	5	mBar	-	-	Pressure	-	-	Diagnostic	Supply Voltage

5 Generic information

The qualitative level of our instruments is the result of a continuous evolution of the product. This may cause differences between what is reported in the manual and the instrument you have purchased.

Siap+Micros S.p.A. reserves the right to modify without notice technical specifications and dimensions to adapt them to the needs of the product.

5.1 Safety

Please read these safety instructions carefully before using this product:

- The warranty will be void if the product is used differently from the instructions described in this manual.
- Any sign of tampering will void the warranty
- Use the devices only according to the instructions (environmental management, operation, wiring, installation, etc.) provided in this manual
- The correct and safe operation of the device can only be guaranteed if the transport, storage, operation and management of the device are compliant. This also applies to product maintenance.
- The device shall not be exposed to aggressive chemicals or solvents that could damage the plastic casing and/or corrode the metal parts.
- Maintenance should only be performed by qualified and well trained personnel.

It is appropriate to carry out a careful risk assessment in relation to the context of installation and use of the device by the installer considering the possible meteorological station in its complexity without being limited to the sensor.

The instruments must be installed according to the rules of the trade, with equipment that complies with applicable regulations and using supports correctly sized by qualified technicians and designed for the specific purpose.

During installation operations, check the suitability of the surrounding environment and compliance with local safety regulations.

The manufacturer declines all responsibility in case of failure due to negligence of the instructions, tampering, uses not described in this manual, improper use, use by operators not trained.

Read the instructions and intended use carefully and be sure you understand before installing the device

Before starting the activities, check the integrity of the instrument to be installed, prepare the equipment necessary for the work and wear the necessary PPE.

Take adequate measures to prevent the access of foreign personnel (untrained and uninformed) during the installation, maintenance or replacement of the instrument.

Take precautions to avoid falling objects, both during the installation phases and during the operation of the instrument.

Do not perform any activity in bad weather conditions.

During maintenance, particularly if the station is not frequented, visually check for the absence of dangerous insects and, if not, use suitable insecticides.

Consider the presence of any animals near the station, if so, pay attention to them.

Use only SIAP+MICROS original spare parts.

The instrument is not classified suitable (according to Directive 2014/34/EU) for use in atmospheres with potential explosion risk pursuant to Directive 99/92/EC.

SIAP+MICROS strives to minimize health and safety risks in all phases of the instrument's life, including installation, use, maintenance, decommissioning and disposal.

5.2 Appropriate use of the equipment

Use the instrument for its intended purpose, do not use it for any other purpose or cause malfunctions and/or damage.

5.3 Storage

If you do not plan to use the equipment for an extended period of time (at least one year) disconnect all cables from the equipment, place it in a clear plastic bag along with a bag of desiccant salts and seal the bag with tape. Put appropriate indication on the bag of the contents and weight of the equipment by inserting the wording "HANDLE WITH CARE".

Store the instrument in an environment with a temperature between 0°C and 60°C with a humidity not exceeding 80%. Make sure that the instrument is stored in a stable position and that it cannot be damaged or moved by inexperience or carelessness. Do not stack other tools or weights. Do not place the instrument on top of other instruments and in any case ensure the solidity and stability of the underlying support.

Non esporre, stoccare lo strumento in ambienti con presenza di vapori e/o gas corrosivi.

5.4 Moving

In order to avoid any damage to the device during transportation, please keep it in upright position without shaking.

5.5 Disposal information



Electrical and electronic equipment marked with specific symbol in compliance with 2012/19/EU Directive must be disposed of separately from household waste. European users can hand them over to the dealer or to the manufacturer when purchasing a new electrical and electronic equipment, or to a WEEE collection point designated by local authorities. Illegal disposal is punished by law.

Disposing of electrical and electronic equipment separately from normal waste helps to preserve natural resources and allows materials to be recycled in an environmentally friendly way without risks to human health.

6 Revision history

The following table shows the description of the changes made to this document.

Version	Date	Updates
1.0	05/06/2023	Current version of the document.

All the information content in this document are the current available at the printing phase. Siap+Micros S.p.A. reserve the rights to change the specifications without any advance notice

7 Declaration of Conformity



MD 751.1 rev. 03

EU Declaration of Conformity (DoC)

Manufacturer: SIAP+MICROS S.p.A.
 Via del Lavoro, 1 – 31020 S. Fior (TV) – Italy
<https://www.siapmicros.com/en/>

This declaration of conformity is issued under the sole responsibility of the manufacturer.

Object of the declaration:

Description	Product Code/Model
TBAR - IVS Digital Barometer with 4+20mA, 0-2Vdc and RS485 output	PSM-t011d-TBAR-IVS

The object of the declaration described above is in conformity with the relevant Union harmonization legislation:

- 2014/30/EU Electromagnetic Compatibility (EMC)
- 2011/65/EU The Restriction of Hazardous Substances Directive (RoHSD)

The following harmonised standards and technical specifications have been applied:

EMC references:

EN 61326-1 2021-06	Electrical equipment for measurement, control and laboratory use - EMC requirements - General requirements
------------------------------	---

RoHSD references:

EN 63000 2016+AMD1:2022	Technical documentation for the assessment of electrical and electronic products with respect to the restriction of hazardous substances
-----------------------------------	--

Date
 31-01-2023

CEO
 Alex Stevanin

