

## t017 TBF

Leaf Wetness Transducer

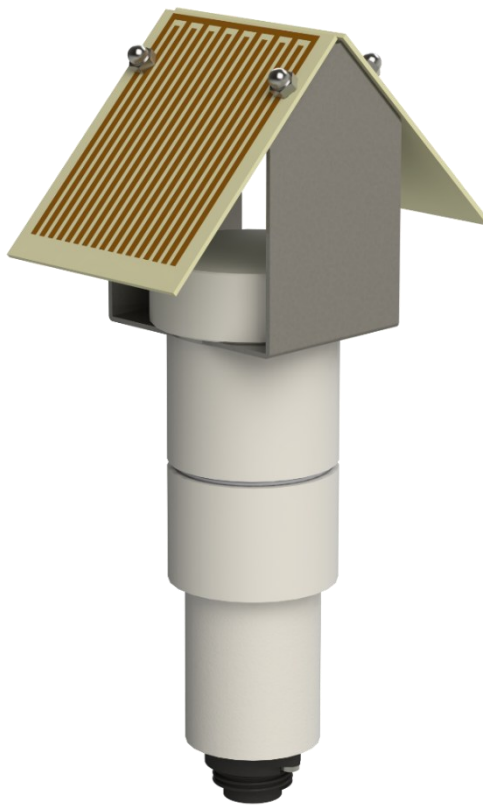

SIAP+MICROS

User Manual and maintenance

## Summary

1	Introduction .....	3
2	Technical specification .....	4
3	Installation and maintenance .....	6
3.1	Installation .....	6
3.2	Maintenance .....	6
4	Electrical connection .....	7
4.1	Connector output .....	7
4.2	Connection cable .....	7
5	Generic information .....	8
5.1	Safety .....	8
5.2	Appropriate use of the equipment .....	9
5.3	Storage .....	9
5.4	Moving .....	9
5.5	Disposal information .....	9
6	Revision history .....	10
7	Declaration of Conformity .....	11

## 1 Introduction

---

TBF is a basic sensor for agrometeorology, typically used to investigate with a very high precision the persistence of water drops above the leaf surface. This indicator is fundamental to measure the residence time of water drops on the leaves, in order to identify phytopathological risks or the leaching of treatments from crops. TBF sensing element consists of two gilded copper electrical circuits placed on glassonite plates, which are specifically tilted to simulate a real leaf. Once the surface gets wet (for rain, condensation, dew, ice, etc.), the system enters into conduction closing the electrical contact. Sensor body is overall made of high-quality plastic, but particularly the sensing element is mounted on an anticorrosive aluminium alloy support. The protection screen is made of non-hygroscopic, UV resistant and low thermal capacity plastic material, to ensure long-term stability. The sensor is supplied with power and signal cable (4 m).

### Ordering codes:

Natural output: ..... t018-TTEP-N

## 2 Technical specification

<b>Measurement performance</b>			
Transducer	Two gilded copper electrical circuits placed on glassonite plates		
Measurement range	ON / OFF		
Sensibility	1 s		
Accuracy	1 s		
<b>Operating conditions</b>			
Temperature	0 ÷ +60 °C		
Humidity	0 ÷ 100 %		
<b>Outputs</b>			
Natural	Open drain (relay contact upon request)		
Maximum tension open drain output	24 V		
Maximum current open drain output	400 mA		
Maximum tension reed contact output	30 W		
Maximum current reed contact output	1000 mA		
<b>Power supply and Consumption</b>			
Voltage supply	6 ÷ 22 Vdc		
Power consumption	Min	Typical	Max
	Open Drain	1.5	
	Relay contact	15	
<b>Mechanical specifications</b>			
Protective body	Plastic and stainless steel, sensing element in copper and glassonite.		

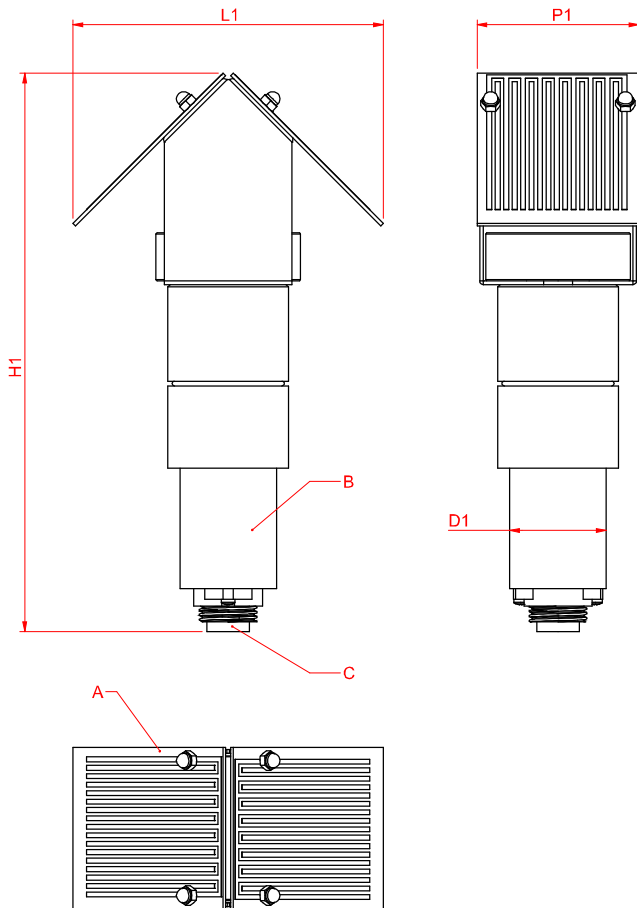

**Dimension:**

**H1** – maximum hight: 232 mm

**P1** - depth: 67 mm

**L1** - lenght: 130 mm

**D1** – fixing diameter: 40 mm

**Element:**

**A** – sensitive element

**B** – fixing shank

**C** – output connector

**Weight:** 410 g

### **3 Installation and maintenance**

---

#### **3.1 Installation**

---

For correct installation, the monitoring station should be placed at a distance from the closest obstacle (pylons, trees, buildings) equal to 10 times the height of the obstacle itself.

Normally, according to WMO standards, the installation height of the sensor must be between 1.25 and 2 meters.

As illustrated in the image below, the sensor must be fixed to the plastic stem with jumpers, or similar elements, of 40mm diameter indiscriminately in any position of the standard Siap+Micros support bracket.

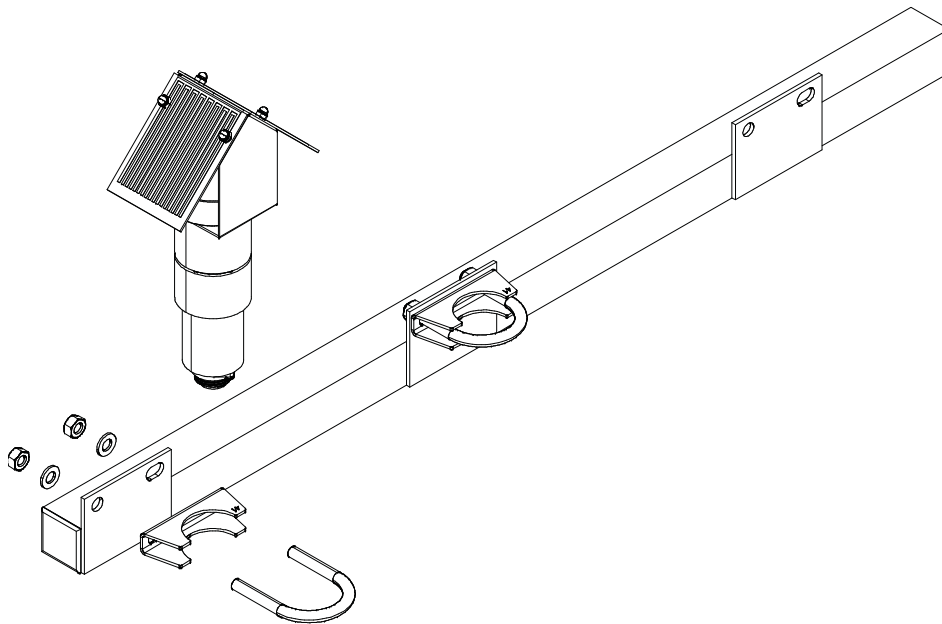

#### **3.2 Maintenance**

---

This type of transducer does not require particular maintenance operations: periodic cleaning of the rain detection plates is recommended, at least every 6 months or when necessary, to eliminate dirt deposits present on the plate.

## 4 Electrical connection

### 4.1 Connector output

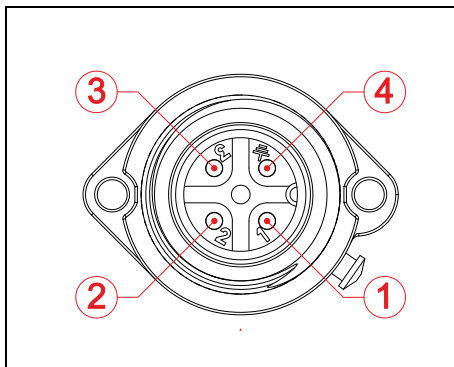
	Pin	Output
	1	Vcc
	2	Contact
	3	Contact
	4	GND

### 4.2 Connection cable

The connection cable supplied with the sensor is made with circular connectors with housing, 4x24 AWG shielded cable and ferrules for connection to the data logger terminals. The sock is connected to the black cable.

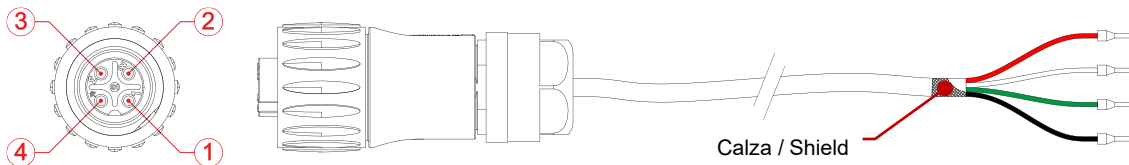

Pin	1	2	3	4
<b>Cable</b>	Red	White	Green	Black+Shield
<b>Signal</b>	Vcc	Contact	Contact	GND

## 5 Generic information

---

The qualitative level of our instruments is the result of a continuous evolution of the product. This may cause differences between what is reported in the manual and the instrument you have purchased.

Siap+Micros S.p.A. reserves the right to modify without notice technical specifications and dimensions to adapt them to the needs of the product.

### 5.1 Safety

---

Please read these safety instructions carefully before using this product:

- The warranty will be void if the product is used differently from the instructions described in this manual.
- Any sign of tampering will void the warranty
- Use the devices only according to the instructions (environmental management, operation, wiring, installation, etc.) provided in this manual
- The correct and safe operation of the device can only be guaranteed if the transport, storage, operation and management of the device are compliant. This also applies to product maintenance.
- The device shall not be exposed to aggressive chemicals or solvents that could damage the plastic casing and/or corrode the metal parts.
- Maintenance should only be performed by qualified and well trained personnel.

It is appropriate to carry out a careful risk assessment in relation to the context of installation and use of the device by the installer considering the possible meteorological station in its complexity without being limited to the sensor.

The instruments must be installed according to the rules of the trade, with equipment that complies with applicable regulations and using supports correctly sized by qualified technicians and designed for the specific purpose.

During installation operations, check the suitability of the surrounding environment and compliance with local safety regulations.

The manufacturer declines all responsibility in case of failure due to negligence of the instructions, tampering, uses not described in this manual, improper use, use by operators not trained.

Read the instructions and intended use carefully and be sure you understand before installing the device

Before starting the activities, check the integrity of the instrument to be installed, prepare the equipment necessary for the work and wear the necessary PPE.

Take adequate measures to prevent the access of foreign personnel (untrained and uninformed) during the installation, maintenance or replacement of the instrument.

Take precautions to avoid falling objects, both during the installation phases and during the operation of the instrument.

Do not perform any activity in bad weather conditions.

During maintenance, particularly if the station is not frequented, visually check for the absence of dangerous insects and, if not, use suitable insecticides.

Consider the presence of any animals near the station, if so, pay attention to them.

Use only SIAP+MICROS original spare parts.

The instrument is not classified suitable (according to Directive 2014/34/EU) for use in atmospheres with potential explosion risk pursuant to Directive 99/92/EC.

SIAP+MICROS strives to minimize health and safety risks in all phases of the instrument's life, including installation, use, maintenance, decommissioning and disposal.

## **5.2 Appropriate use of the equipment**

---

Use the instrument for its intended purpose, do not use it for any other purpose or cause malfunctions and/or damage.

## **5.3 Storage**

---

If you do not plan to use the equipment for an extended period of time (at least one year) disconnect all cables from the equipment, place it in a clear plastic bag along with a bag of desiccant salts and seal the bag with tape. Put appropriate indication on the bag of the contents and weight of the equipment by inserting the wording "HANDLE WITH CARE".

Store the instrument in an environment with a temperature between 0°C and 60°C with a humidity not exceeding 80%. Make sure that the instrument is stored in a stable position and that it cannot be damaged or moved by inexperience or carelessness. Do not stack other tools or weights. Do not place the instrument on top of other instruments and in any case ensure the solidity and stability of the underlying support.

Non esporre, stoccare lo strumento in ambienti con presenza di vapori e/o gas corrosivi.

## **5.4 Moving**

---

In order to avoid any damage to the device during transportation, please keep it in upright position without shaking.

## **5.5 Disposal information**

---



Electrical and electronic equipment marked with specific symbol in compliance with 2012/19/EU Directive must be disposed of separately from household waste. European users can hand them over to the dealer or to the manufacturer when purchasing a new electrical and electronic equipment, or to a WEEE collection point designated by local authorities. Illegal disposal is punished by law.

Disposing of electrical and electronic equipment separately from normal waste helps to preserve natural resources and allows materials to be recycled in an environmentally friendly way without risks to human health.

## 6 *Revision history*

---

The following table shows the description of the changes made to this document.

<b>Version</b>	<b>Date</b>	<b>Updates</b>
1.0	05/06/2023	<i>Current version of the document.</i>

All the information content in this document are the current available at the printing phase. Siap+Micros S.p.A. reserve the rights to change the specifications without any advance notice

## 7 Declaration of Conformity



MD 751.1 rev. 03

### EU Declaration of Conformity (DoC)

**Manufacturer:** SIAP+MICROS S.p.A.  
 Via del Lavoro, 1 – 31020 S. Fior (TV) – Italy  
<https://www.siapmicros.com/en/>

This declaration of conformity is issued under the sole responsibility of the manufacturer.

**Object of the declaration:**

Description	Product Code/Model
TBF-N Leaf Wetness Transducer with open drain/contact contatto output	PSM-t017-TBF-N

The object of the declaration described above is in conformity with the relevant Union harmonization legislation:

- 2014/30/EU Electromagnetic Compatibility (EMC)
- 2011/65/EU The Restriction of Hazardous Substances Directive (RoHSD)

The following harmonised standards and technical specifications have been applied:

**EMC references:**

<b>EN 61326-1</b> 2021-06	Electrical equipment for measurement, control and laboratory use - EMC requirements - General requirements
------------------------------	--

**RoHSD references:**

<b>EN 63000</b> 2016+AMD1:2022	Technical documentation for the assessment of electrical and electronic products with respect to the restriction of hazardous substances
-----------------------------------	--

**Date**  
 31-01-2023

**CEO**  
 Alex Stevanin

