

t020 TTA

Water Temperature Transducer



SIAP+MICROS

User Manual and maintenance

Summary

1	Introduction	3
2	Technical specificaion	4
3	Installation and maintenance	5
3.1	Installation	5
3.2	Maintenance	5
4	Electrical connection	6
4.1	Natural Version connections	6
4.2	Version I, V, S connections	6
4.2.1	Connector output	6
4.2.2	Connection cable	6
4.3	Data readinding in serial	7
4.3.1	RS485 Modbus mode	7
5	Generic information	8
5.1	Safety	8
5.2	Appropriate use of the equipment	9
5.3	Storage	9
5.4	Moving	9
5.5	Disposal information	9
6	Revision history	10

1 Introduction

The sensing element is made up of Pt100 platinum thermoresistance with response curve according to DIN 43760 class 1/3 standards. Intelligent Sensors: The transducer belongs to the family of intelligent sensors as it is equipped with an internal micro-processor which performs, among other functions: control of correct operation, data pre-processing, A/D conversion of electrical signals, etc. These features ensure excellent accuracy, high data reliability. The sensor can be accompanied by a Siap+Micros calibration certificate or by certificates issued by other external laboratories (SIT, Colonnetti, etc.). The body of the sensor is made of PVC, it is equipped with an IP-67 connector and 15 m of cable. The transducer complies with the provisions of the European EMC regulations, is protected against overvoltages and fully complies with the prescriptions of the WMO (World Meteorological Organization)

Ordering codes:

Natural output: t020-TTA-N
Current output: t020a-TTA-I
Tension output: t020b-TTA-V
RS485 Modbus output: t020c-TTA-S

2 Technical specificaion

Measurement performance			
Transducer	Pt100 1/3 DIN 43760		
Measurement range	-30 ÷ 60 °C		
Accuracy (current, tension, serial outputs)	1/3 DIN 43760		
Resolution	0.1		
Operating conditions			
Temperature	-30 ÷ +60 °C		
Output			
Natural	Pt100 a 4 fili		
Current	4 ÷ 20 mA ↔ -30 ÷ 60 °C		
Tension	0 ÷ 2 V ↔ -30 ÷ 60 °C		
RS485 MODBUS	Temperatura		
Power supply and Consumption			
Voltage supply (non-natural output versions)	7 ÷ 30 Vdc		
Power consumption	Min	Typical	Max
4 ÷ 20 mA	5		25
0 ÷ 2 V / RS485 MODBUS		1	3
Mechanical specifications			
Protective body	Plastic material		
Electrical connections	P67 / 4 male poles		

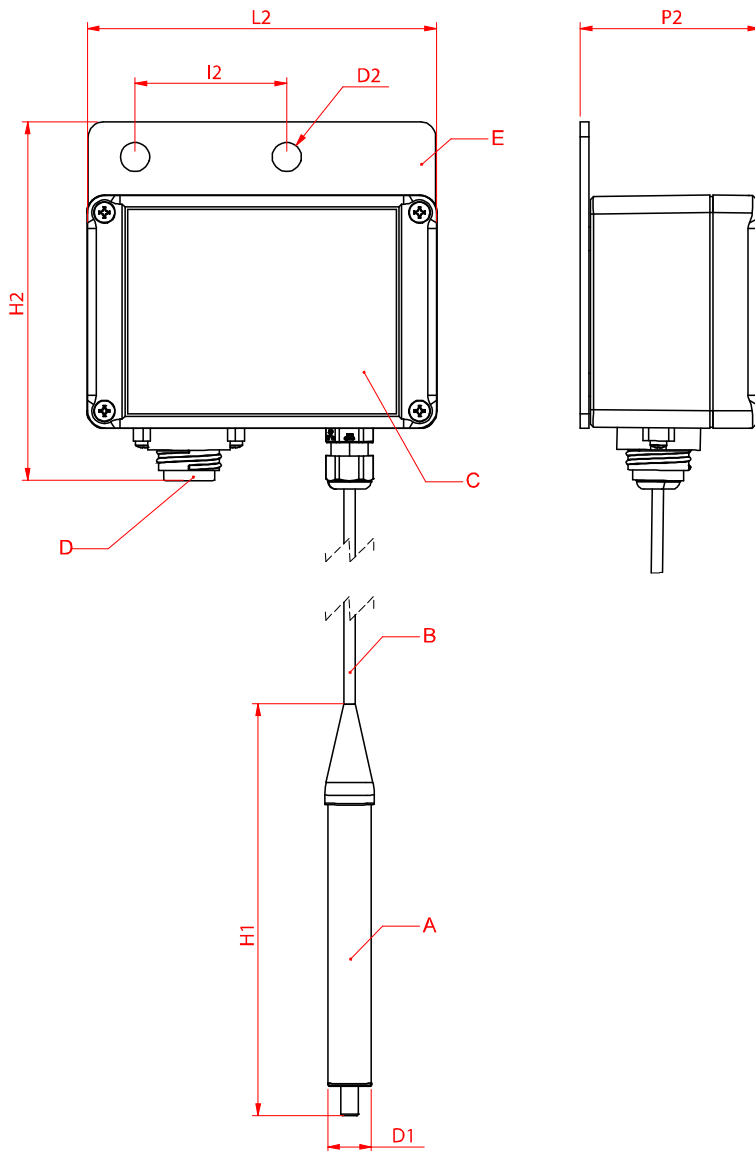

Probe Dimension:

H1 – length: 140 mm

D1 – diameter: 15 mm

Box dimension:

L2 – length: 120 mm

H2 – total height: 122 mm

H3 – box height: 80 mm

P2 – depth: 62 mm

I2 – hole spacing 52 mm

D2 – diameter: 10 mm

Element:

A – probe TTA

B – connection cable (~15m)

C – electronic container (only I, V e S)

D – connector (only I, V e S)

E– backing plate

Weight (probe only): 150 gr

3 Installation and maintenance

3.1 Installation

The body of the probe is immersed in the liquid whose temperature is to be measured. If the situation requires it, the probe can be protected with an adequate stilling and protection pipe.

In the versions with non-natural outlet, the container with the electronics must be positioned in a place suitably distant and protected from the body of water. The container can be fixed using the 2 holes on the fixing bracket. A connection cable is provided for connection to the data logger.

3.2 Maintenance

No particular maintenance is required other than the periodic check of the measuring point and the quality of the acquired measurement. In case of malfunction, replace the sensor and send it for inspection and verification at the factory.

4 Electrical connection

4.1 Natural Version connections

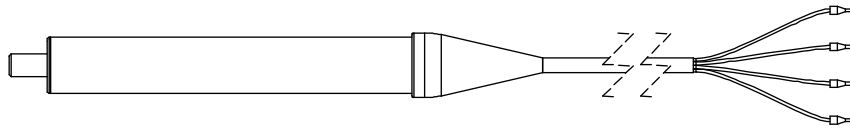

Cable	Red	White	Green	Black+Shield
Signal	I+	V+	V-	I-

4.2 Version I, V, S connections

Below is the pinout of the connector on the signal conversion electronics.

4.2.1 Connector output

	Pin	I / V / S / SDI12 output
	1	Vcc
	2	+4÷20 mA +0÷2 Vdc B-RS485
	3	-4÷20 mA -0÷2 Vdc A-RS485
	4	GND

4.2.2 Connection cable

The connection cable supplied with the sensor is made with circular connectors with housing, 4x24 AWG shielded cable and ferrules for connection to the data logger terminals. The sock is connected to the black cable.

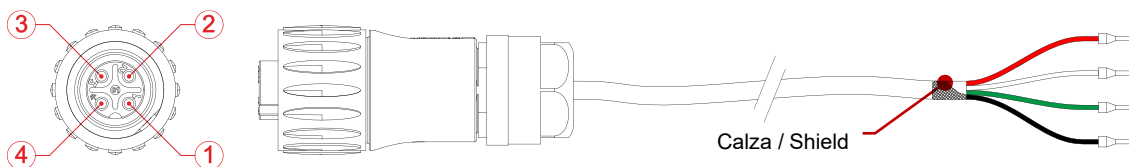

Pin	1	2	3	4
Cable	Red	White	Green	Black+Shield
Signal	Vcc (alim.)	+4÷20 mA +0÷2 Vdc B-RS485	-4÷20 mA -0÷2 Vdc A-RS485	GND (alim.)

4.3 Data reading in serial

Sensors with RS485 Modbus output send data only upon specific request from the PC, data logger or PLC.

Below are the correct communication parameters of the device performing the interrogation.

4.3.1 RS485 Modbus mode

Serial port settings: 9600 baud, no parity, 8 data bit, 1 bit di stop

Compatible with ModBus RTU protocol, supported functions: “03 – read Holding Registers” e “04 – Read Input Registers”.

Data Type: “2 registers swapped float IEEE 754 in the form CDAB where A is the most significant byte of the float and D is the less significant byte of the float (swapped float)”.

ID	Registers	Units	Reg. 1-2	Reg. 3-4	Reg. 5-6	Reg. 7-8	Reg. 9-10	Reg. 11-12	Reg. 13-14
3	1	°C	Temperature	-	-	-	-	Diagnostic	Supply Voltage

5 Generic information

The qualitative level of our instruments is the result of a continuous evolution of the product. This may cause differences between what is reported in the manual and the instrument you have purchased.

Siap+Micros S.p.A. reserves the right to modify without notice technical specifications and dimensions to adapt them to the needs of the product.

5.1 Safety

Please read these safety instructions carefully before using this product:

- The warranty will be void if the product is used differently from the instructions described in this manual.
- Any sign of tampering will void the warranty
- Use the devices only according to the instructions (environmental management, operation, wiring, installation, etc.) provided in this manual
- The correct and safe operation of the device can only be guaranteed if the transport, storage, operation and management of the device are compliant. This also applies to product maintenance.
- The device shall not be exposed to aggressive chemicals or solvents that could damage the plastic casing and/or corrode the metal parts.
- Maintenance should only be performed by qualified and well trained personnel.

It is appropriate to carry out a careful risk assessment in relation to the context of installation and use of the device by the installer considering the possible meteorological station in its complexity without being limited to the sensor.

The instruments must be installed according to the rules of the trade, with equipment that complies with applicable regulations and using supports correctly sized by qualified technicians and designed for the specific purpose.

During installation operations, check the suitability of the surrounding environment and compliance with local safety regulations.

The manufacturer declines all responsibility in case of failure due to negligence of the instructions, tampering, uses not described in this manual, improper use, use by operators not trained.

Read the instructions and intended use carefully and be sure you understand before installing the device

Before starting the activities, check the integrity of the instrument to be installed, prepare the equipment necessary for the work and wear the necessary PPE.

Take adequate measures to prevent the access of foreign personnel (untrained and uninformed) during the installation, maintenance or replacement of the instrument.

Take precautions to avoid falling objects, both during the installation phases and during the operation of the instrument.

Do not perform any activity in bad weather conditions.

During maintenance, particularly if the station is not frequented, visually check for the absence of dangerous insects and, if not, use suitable insecticides.

Consider the presence of any animals near the station, if so, pay attention to them.

Use only SIAP+MICROS original spare parts.

The instrument is not classified suitable (according to Directive 2014/34/EU) for use in atmospheres with potential explosion risk pursuant to Directive 99/92/EC.

SIAP+MICROS strives to minimize health and safety risks in all phases of the instrument's life, including installation, use, maintenance, decommissioning and disposal.

5.2 Appropriate use of the equipment

Use the instrument for its intended purpose, do not use it for any other purpose or cause malfunctions and/or damage.

5.3 Storage

If you do not plan to use the equipment for an extended period of time (at least one year) disconnect all cables from the equipment, place it in a clear plastic bag along with a bag of desiccant salts and seal the bag with tape. Put appropriate indication on the bag of the contents and weight of the equipment by inserting the wording "HANDLE WITH CARE".

Store the instrument in an environment with a temperature between 0°C and 60°C with a humidity not exceeding 80%. Make sure that the instrument is stored in a stable position and that it cannot be damaged or moved by inexperience or carelessness. Do not stack other tools or weights. Do not place the instrument on top of other instruments and in any case ensure the solidity and stability of the underlying support.

Non esporre, stoccare lo strumento in ambienti con presenza di vapori e/o gas corrosivi.

5.4 Moving

In order to avoid any damage to the device during transportation, please keep it in upright position without shaking.

5.5 Disposal information



Electrical and electronic equipment marked with specific symbol in compliance with 2012/19/EU Directive must be disposed of separately from household waste. European users can hand them over to the dealer or to the manufacturer when purchasing a new electrical and electronic equipment, or to a WEEE collection point designated by local authorities. Illegal disposal is punished by law.

Disposing of electrical and electronic equipment separately from normal waste helps to preserve natural resources and allows materials to be recycled in an environmentally friendly way without risks to human health.

6 Revision history

The following table shows the description of the changes made to this document.

Version	Date	Updates
1.0	05/06/2023	Current version of the document.

All the information content in this document are the current available at the printing phase. Siap+Micros S.p.A. reserve the rights to change the specifications without any advance notice