

t023b TNU08

Ultrasound Transducer



User Manual and maintenance

SIAP+MICROS

Summary

1	Introduction	3
2	Technical specificaion	4
2.1	Operation scheme	5
3	Installation and maintenance	6
3.1	Installation.....	6
3.2	Maintenance	6
4	Electrical connection.....	7
4.1	Connector output	7
4.2	Connection cable	7
4.3	Data readinding in serial (RS485 Modbus)	7
4.3.1	RS485 Modbus mode	7
5	Generic information	8
5.1	Safety.....	8
5.2	Appropriate use of the equipment	9
5.3	Storage	9
5.4	Moving	9
5.5	Disposal information	9
6	Revision history	10
7	Declaration of Conformity	11

1 Introduction

The TNU08 sensor measures snow depth up to 8 meters by emitting short ultrasonic pulses toward the snow surface and detecting the returning echoes. The TNU guarantees excellent performance in terms of accuracy thanks to a self-correcting measurement system which, using an integrated temperature sensor, takes into account variations in the speed of sound depending on air density. The on-board electronics calculate the distance based on the time intervals between the emission and reception of the reflected pulses. In particular, the TNU is equipped with an electronic amplification and detection system specifically designed for snow cover applications. Snow has high sound-absorbing properties (it reflects the pulse not only from the outer surface but also from the layers beneath the surface). The protective outer casing contains the transducer and is partly made up of a self-ventilating sun shield to allow for accurate air temperature measurement and to protect the sensitive component from direct exposure to atmospheric agents. The sensor is supplied complete with power and signal cable (12 m).

Ordering Codes:

Range 0÷8 m: t023b-TNU08-IVS

2 Technical specificaion

Measurement performance			
Measurement range (TNU08)	0.8 ÷ 8m		
Accuracy	±1 cm		
Sensibility	0.5 cm		
Beam width(3dB)	12° ± 2°		
Operating conditions			
Temperature	-20 ÷ +65 °C		
Humidity	0 ÷ 100 RH%		
Outputs			
TNU08	Tension	0 ÷ 2 V ↔ 0 ÷ 10 m	
	Current	4 ÷ 20 mA ↔ 0 ÷ 10 m	
	RS485 MODBUS	Temperature, Snow Level	
Power supply and consumption			
Voltage supply (non-natural output versions)	10 ÷ 16 Vdc		
Consumption	Min	Tipico	Massimo
4 ÷ 20 mA	7		30
0 ÷ 2 V / RS485 MODBUS (TNU08)		1.5	
Capsule piloting power (peak)	14.4 W		
Mechanical specifications			
Protective body	Plastic material (ABS), aluminium and stainless steel screws		
Electrical connections	IP67 / 7 male poles		

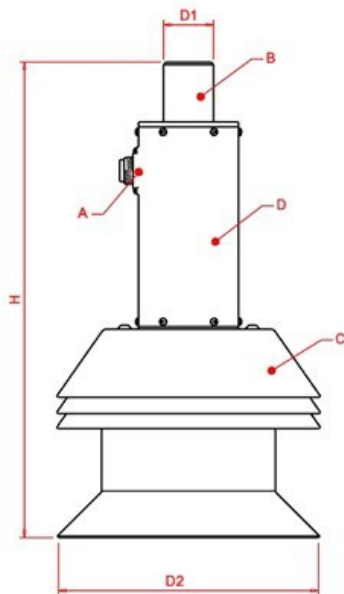

Dimension:	TNU08
H – maximum height	400mm
D1 – fixing diameter	40mm
D2 – maximum diameter	210mm

Elementi:

- A** – connector
- B** – support stem
- C** – ultrasonic capsule protection and air temperature sensor
- D** – central body in aluminium

Weight:

TNU08: 2.3 kg

2.1 Operation scheme

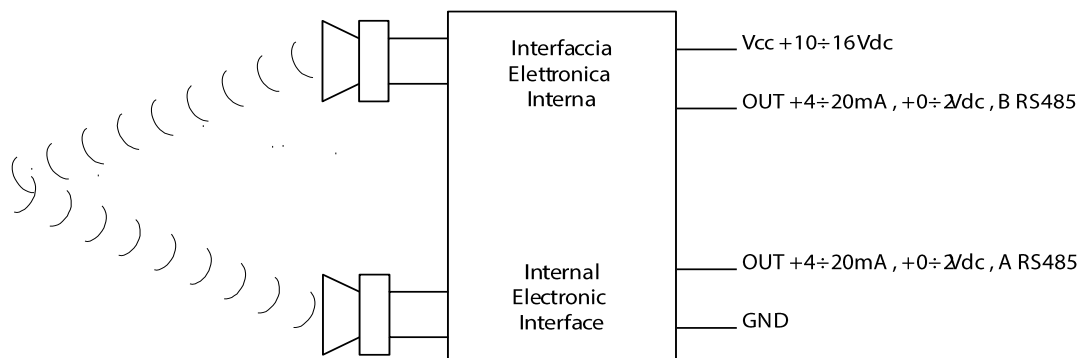

3 **Installation and maintenance**

3.1 **Installation**

The TNU sensor, in all its versions, can be installed on special Siap+Micros arms equipped with a terminal plate for the attachment of 40mm diameter U-bolts (see the example in the image to the side).

The length of the arm used can vary according to the measurement needs.

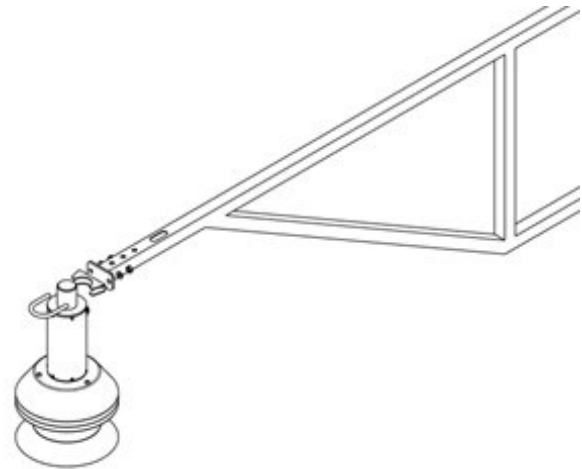

N.B.: the sensor has a 12° measuring cone, when choosing the site or installation method it is necessary to take this into account, taking care not to have obstacles inside this cone so as not to detect the presence of objects other than layer of snow on which to perform the measurement.

3.2 **Maintenance**

The sensor has no particular maintenance requirements. For a correct and constant accuracy of the measurement, the area below the sensor inside the measuring cone (12°) must be kept clean and free from obstacles, even temporary ones.

However, it is advisable to periodically check that it is working properly in the factory with sample instruments.

4 Electrical connection

4.1 Connector output

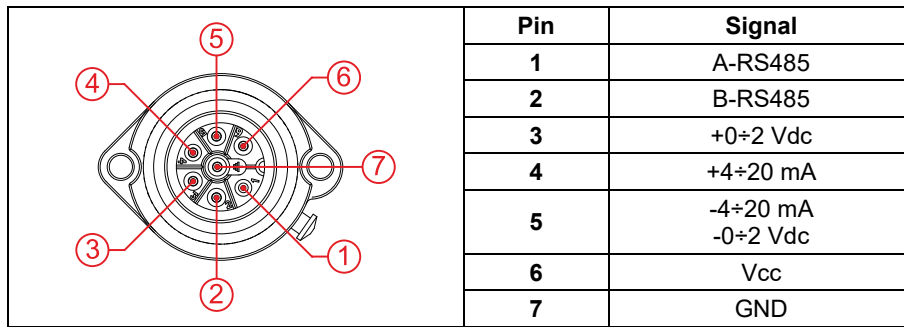

4.2 Connection cable

The connection cable supplied with the sensor is made with circular connectors with housing, 6 x 22 mmq + 2 x 2.5 mmq shielded cable and ferrules for connection to the data logger terminals. The braid is connected to the general ground lead.

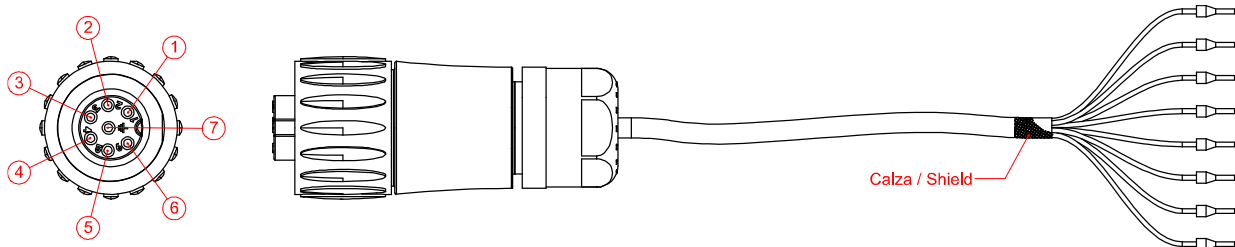

Pin	1	2	3	4	5	6	7	7
Cable	Blue	White	Green	Black	Yellow	Blue (2.5mmq)	Brown (2.5mmq)	Red
Signal	A-RS485	B-RS485	+0÷2 Vdc	+4÷20 mA	-4÷20 mA -0÷2 Vdc	Vcc	GND	GND

4.3 Data reading in serial (RS485 Modbus)

Sensors with RS485 Modbus output send data only upon specific request from the PC, data logger or PLC.

Below are the correct communication parameters of the device performing the interrogation.

4.3.1 RS485 Modbus mode

Serial port settings: 9600 baud, no parity, 8 data bits, 1 stop bit

Compatible with ModBus RTU protocol, supported functions: "03 – read Holding Registers" and "04 – Read Input Registers".

Data type: "2 registers swapped float IEEE 754 in the form CDAB where A is the most significant byte of the float and D is the less significant byte of the float (swapped float)".

ID	Registers	Units	Reg. 1-2	Reg. 3-4	Reg. 5-6	Reg. 7-8	Reg. 9-10	Reg. 11-12	Reg. 13-14
21	3	m	-	Distance from sensor	-	-	-	Diagnostic	Supply Voltage

5 Generic information

The qualitative level of our instruments is the result of a continuous evolution of the product. This may cause differences between what is reported in the manual and the instrument you have purchased.

Siap+Micros S.p.A. reserves the right to modify without notice technical specifications and dimensions to adapt them to the needs of the product.

5.1 Safety

Please read these safety instructions carefully before using this product:

- The warranty will be void if the product is used differently from the instructions described in this manual.
- Any sign of tampering will void the warranty
- Use the devices only according to the instructions (environmental management, operation, wiring, installation, etc.) provided in this manual
- The correct and safe operation of the device can only be guaranteed if the transport, storage, operation and management of the device are compliant. This also applies to product maintenance.
- The device shall not be exposed to aggressive chemicals or solvents that could damage the plastic casing and/or corrode the metal parts.
- Maintenance should only be performed by qualified and well trained personnel.

It is appropriate to carry out a careful risk assessment in relation to the context of installation and use of the device by the installer considering the possible meteorological station in its complexity without being limited to the sensor.

The instruments must be installed according to the rules of the trade, with equipment that complies with applicable regulations and using supports correctly sized by qualified technicians and designed for the specific purpose.

During installation operations, check the suitability of the surrounding environment and compliance with local safety regulations.

The manufacturer declines all responsibility in case of failure due to negligence of the instructions, tampering, uses not described in this manual, improper use, use by operators not trained.

Read the instructions and intended use carefully and be sure you understand before installing the device

Before starting the activities, check the integrity of the instrument to be installed, prepare the equipment necessary for the work and wear the necessary PPE.

Take adequate measures to prevent the access of foreign personnel (untrained and uninformed) during the installation, maintenance or replacement of the instrument.

Take precautions to avoid falling objects, both during the installation phases and during the operation of the instrument.

Do not perform any activity in bad weather conditions.

During maintenance, particularly if the station is not frequented, visually check for the absence of dangerous insects and, if not, use suitable insecticides.

Consider the presence of any animals near the station, if so, pay attention to them.

Use only SIAP+MICROS original spare parts.

The instrument is not classified suitable (according to Directive 2014/34/EU) for use in atmospheres with potential explosion risk pursuant to Directive 99/92/EC.

SIAP+MICROS strives to minimize health and safety risks in all phases of the instrument's life, including installation, use, maintenance, decommissioning and disposal.

5.2 Appropriate use of the equipment

Use the instrument for its intended purpose, do not use it for any other purpose or cause malfunctions and/or damage.

5.3 Storage

If you do not plan to use the equipment for an extended period of time (at least one year) disconnect all cables from the equipment, place it in a clear plastic bag along with a bag of desiccant salts and seal the bag with tape. Put appropriate indication on the bag of the contents and weight of the equipment by inserting the wording "HANDLE WITH CARE".

Store the instrument in an environment with a temperature between 0°C and 60°C with a humidity not exceeding 80%. Make sure that the instrument is stored in a stable position and that it cannot be damaged or moved by inexperience or carelessness. Do not stack other tools or weights. Do not place the instrument on top of other instruments and in any case ensure the solidity and stability of the underlying support.

Non esporre, stoccare lo strumento in ambienti con presenza di vapori e/o gas corrosivi.

5.4 Moving

In order to avoid any damage to the device during transportation, please keep it in upright position without shaking.

5.5 Disposal information



Electrical and electronic equipment marked with specific symbol in compliance with 2012/19/EU Directive must be disposed of separately from household waste. European users can hand them over to the dealer or to the manufacturer when purchasing a new electrical and electronic equipment, or to a WEEE collection point designated by local authorities. Illegal disposal is punished by law.

Disposing of electrical and electronic equipment separately from normal waste helps to preserve natural resources and allows materials to be recycled in an environmentally friendly way without risks to human health.

6 *Revision history*

The following table shows the description of the changes made to this document.

Version	Date	Updates
1.0	05/06/2023	<i>Current version of the document.</i>

All the information content in this document are the current available at the printing phase. Siap+Micros S.p.A. reserve the rights to change the specifications without any advance notice

7 Declaration of Conformity



MD 751.1 rev. 03

EU Declaration of Conformity (DoC)

Manufacturer: SIAP+MICROS S.p.A.
 Via del Lavoro, 1 – 31020 S. Fior (TV) – Italy
<https://www.siapmicros.com/en/>

This declaration of conformity is issued under the sole responsibility of the manufacturer.

Object of the declaration:

Description	Product Code/Model
TNU08-IVS Svow Level Transducer with range 0÷8m, current, voltage and RS485-Modbus serial output	PSM-t023b-TNU08-IVS

The object of the declaration described above is in conformity with the relevant Union harmonization legislation:

- 2014/30/EU Electromagnetic Compatibility (EMC)
- 2011/65/EU The Restriction of Hazardous Substances Directive (RoHSD)

The following harmonised standards and technical specifications have been applied:

EMC references:

EN 61326-1 2021-06	Electrical equipment for measurement, control and laboratory use - EMC requirements - General requirements
------------------------------	--

RoHSD references:

EN 63000 2016+AMD1:2022	Technical documentation for the assessment of electrical and electronic products with respect to the restriction of hazardous substances
-----------------------------------	--

Date
 31-01-2023

CEO
 Alex Stevanin

