

t026 SMATRH

Combined Air and Relative Humidity



User Manual and maintenance

Summary

1	Introduction	3
2	Technical specificaion	4
2.1	Operation scheme	5
3	Installation and maintenance	6
3.1	Installation.....	6
3.2	Maintenance	6
4	Electrical connection.....	7
4.1	Connector output	7
4.2	Connection cable	7
4.3	Data readinding in serial (RS485 Modbus and SDI-12)	9
4.3.1	RS485 Modbus mode	9
4.3.2	SDI-12 mode.....	9
5	Generic information	10
5.1	Safety.....	10
5.2	Appropriate use of the equipment	11
5.3	Storage	11
5.4	Moving	11
5.5	Disposal information	11
6	Revision history	12

1 Introduction

SMATRH is a combined sensor for measuring air temperature and relative humidity. Temperature measurement is taken using a platinum Pt100 resistance thermometer with a response curve compliant with the DIN 43760 Class 1/3 standard and with a 4-wire connection. The humidity measurement is obtained using a laser-cut capacitive polymer transducer connected to an electronic signal conditioning board. The sensor is offered either in the SMATRH-N version with natural output for temperature (4-wire Pt100) and 0-1 V output for humidity, or in the I, V, S, 12 versions (respectively in current, tension, serial Modbus and serial SDI -12 outputs). Serial versions (Modbus or SDI-12) can provide, in addition to the air temperature and humidity measurements, the values of dew and frost points as well. The sensor body is made out of corrosion-resistant aluminum alloy and stainless-steel screws. The sensing elements are protected from the external radiation by a special non-hygroscopic screen made of an intrinsically anti-UV plastic material. Moreover, thanks to its curvy-shape in section the internal natural ventilation is improved, ensuring an ideal environment of measure. These features allow the sensor to have a functioning not affected by the climate factors. SMATRH is supplied with power and signal cable (4 m).

Comparative tests with reference solar screens

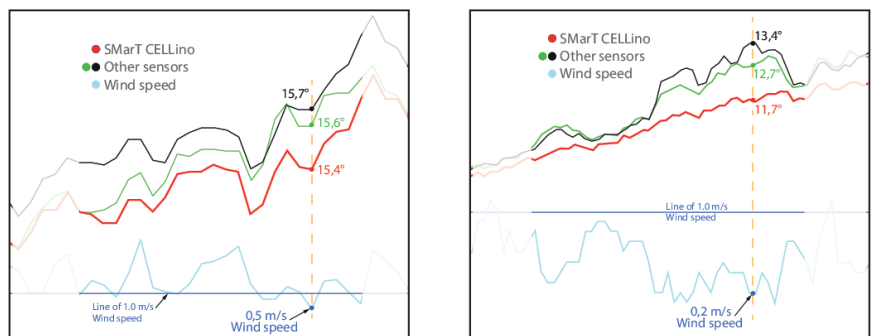

Excellent reactivity even for high temperature gradients

With wind lower than 1 m/S SMarT CELLino guarantees more accurate measurements

Ordering Codes:

Natural output: PSM-t026N-SMATRH-N

Current output: PSM-t026O-SMATRH-I

Tension output: PSM-t026P-SMATRH-V

RS485 Modbus output: PSM-t026Q-SMATRH-S

SDI-12 output: PSM-t026R-SMATRH-12

2 Technical specificaion

Measurement performance			
Transducer	Pt100 1/3 DIN 43760		
Measurement range	-30 ÷ 60 °C		
Accuracy (natural output)	1/3 DIN 43760		
Accuracy (current, tension, serial outputs)	1/3 DIN 43760 ± 0.1		
Resolution	0.03		
Operating conditions			
Temperature	-30 ÷ 60 °C		
Humidity	0 % ÷ 100 RH%		
Outputs			
Natural	Pt100 a 4 fili 0 ÷ 1 V ↔ 0% ÷ 100%		
Current	4 ÷ 20 mA ↔ -30 ÷ 60 °C 4 ÷ 20 mA ↔ 0% ÷ 100%		
Tension	0 ÷ 2 V ↔ -30 ÷ 60 °C 0 ÷ 1 V ↔ 0% ÷ 100%		
RS485 MODBUS	Temperature, relative humidity, dew and frost points		
SDI-12	Temperature, relative humidity, dew and frost points		
Power supply and Consumption			
Voltage supply (Except NATURAL output)	7 ÷ 30 Vdc		
Power consumption	Min	Typical	Max
4 ÷ 20 mA	5		25
0 ÷ 2 V / RS485 MODBUS / SDI-12		1	3
Mechanical specifications			
Protective body	Plastic material (ASA) and stainless-steel screws		
Electrical connections	4/7 male poles IP67		

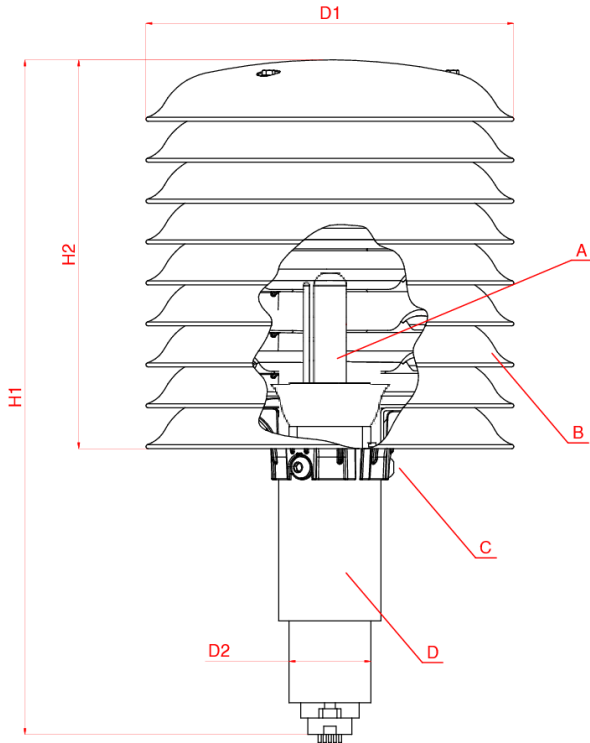

Dimension:

- H1** – maximum height: 310 mm
- H2** - Radiation Shield height: 190 mm
- D1** – maximum diameter: 175 mm
- D2** – fixing diameter: 40 mm

Element:

- A** – sensitive elements Temperature and TH%
- B** – Radiation Shield in ASA
- C** – fixing points to the stem
- D** – Stem of the sensor

Weight: 1,4 kg

2.1 Operation scheme

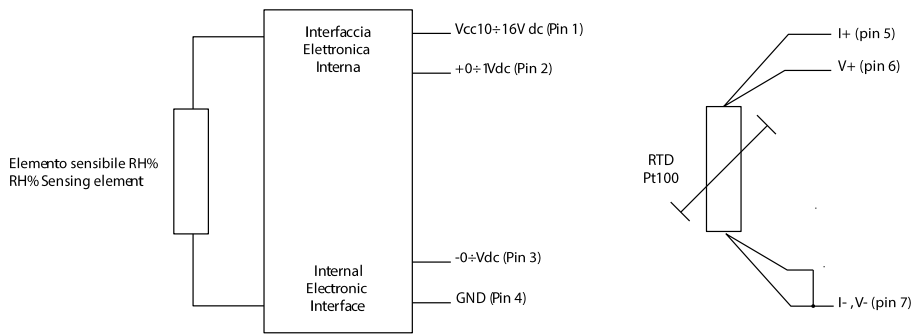

SMATRH-N Version with natural output at Pt100 (Temperature) and 0÷1Vdc (Relative Humidity)

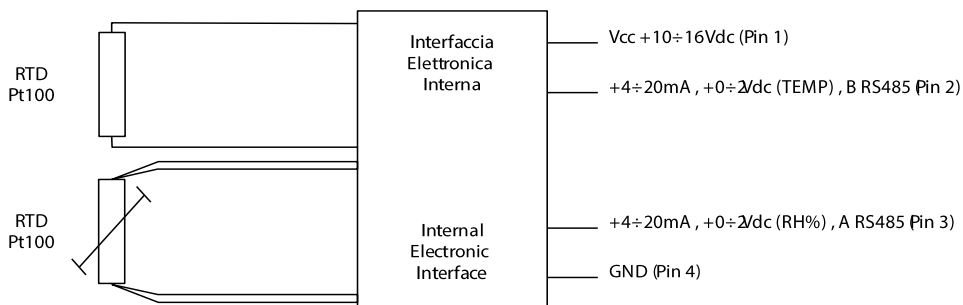

SMATRH-I/V/S Version with 4÷20mA, 0÷Vdc and RS485 output

3 Installation and maintenance

3.1 Installation

The sensor must be installed on special brackets which distance it sufficiently from reflected heat sources (for example the same support pole of the station) which could influence its correct measurement.

For correct installation, the sensor should be placed at a distance from the closest obstacle (pylons, trees, buildings) equal to 10 times the height of the obstacle itself, this to minimize the effects of alteration of the normal air flow.

The sensor must be fixed to the plastic stem with jumpers or similar elements having a diameter of 40mm.

Normally, according to WMO standards, the installation height of the sensor must be between 1.25 and 2 meters.

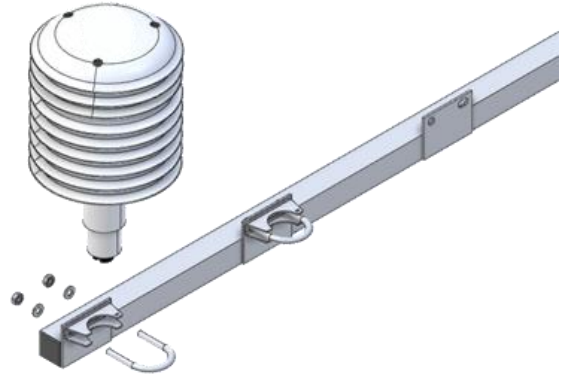

3.2 Maintenance

The temperature sensitive element does not require particular maintenance operations, it is advisable to periodically check the factory calibration with sample instruments.

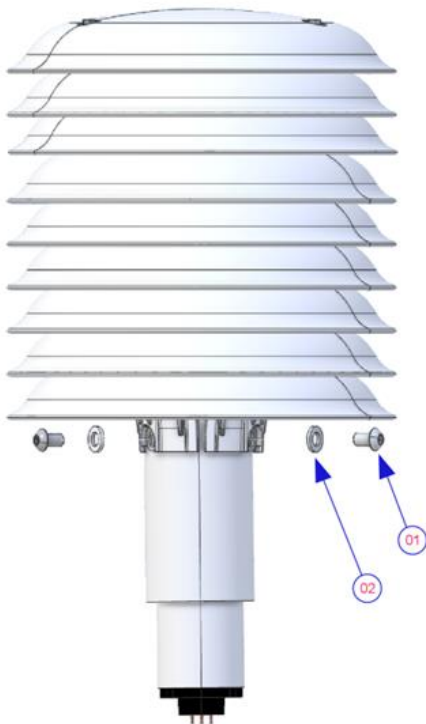

While that of the relative humidity is subject to degradation in relation to the time spent in the external environment and the air quality conditions to which it is subjected: in severe pollution conditions the sensitive element should be replaced after 5+8 months, while in "normal" conditions its good functionality can last up to a year.

A verification of the effectiveness of the measurement can be evaluated by checking the humidity data in a rainy situation: if the value varies between 97% and 99% it can be considered that the sensitive element is still in good condition. It is good practice to periodically check the measurements with standard reference instruments (for example psychrometers).

To clean the hood, unscrew the 3 screws (1) with washers (2) and remove it from the sensor body. Clean it with water and non-aggressive detergent and a normal, non-abrasive sponge (so as not to damage the surface by scratching it).

4 Electrical connection

4.1 Connector output

Version with Natural Output (SMATRH-N) e SDI-12 (SMATRH-12)

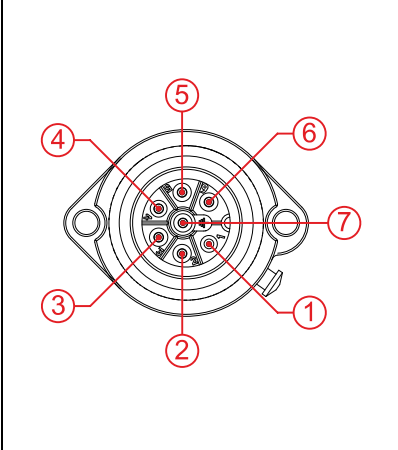
	Pin	Natural output	SDI-12 output
	1	Vcc	A-RS485
	2	RH% +0÷1 Vdc	B-RS485
	3	RH% -0÷1 Vdc	SDI-12 (data)
	4	GND	+4÷20 mA
	5	Temp. I+	-4÷20 mA
	6	Temp. V+	SDI-12 (Vcc)
7	Temp. I- ; V-	GND	

Version with Output in Current (SMATRH-I), Tension (SMATRH-V) e RS485 (SMATRH-S)

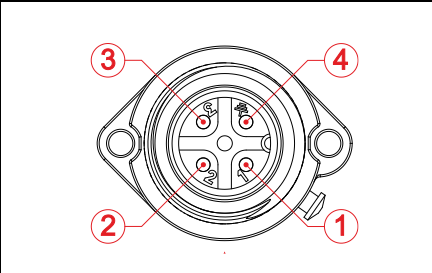
	Pin	I	V	S
	1	Vcc	Vcc	Vcc
	2	Temp. +4÷20 mA	Temp. +0÷2 Vdc	B-RS485
	3	RH% +4÷20 mA	RH% +0÷2 Vdc	A-RS485
4	GND	GND	GND	

4.2 Connection cable

The connection cables supplied with the sensor are made with circular connectors with housing, 8x0.22 mmq cable, 4x0.22 mmq cable, 6x0.22mmq, shielded and with ferrules for connection to the data logger terminals. The braid is connected to the general ground lead.

Version with Natural Output (SMATRH-N)

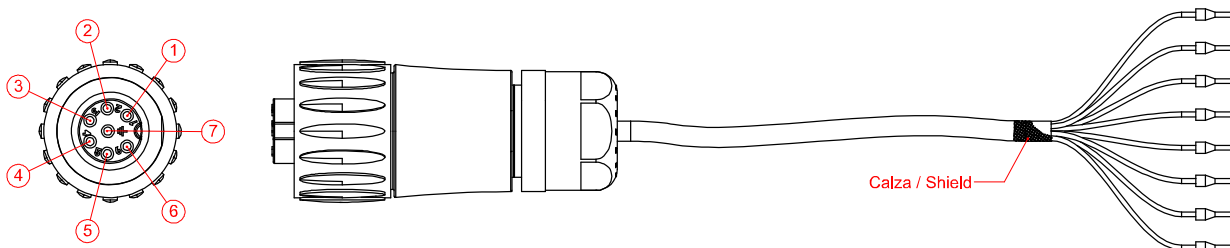

8 pole cable x 0.22mmq								
Pin	1	2	3	4	5	6	7	7
Cable	Red	White	Green	Black	Orange	Yellow	Blue	Brown
Signal	Vcc	RH% +0÷1Vdc	RH% -0÷1Vdc	GND	Temp I+	Temp V+	Temp V-	Temp I-

Cable for Current and Voltage Output (SMATRH-I; SMATRH-V)

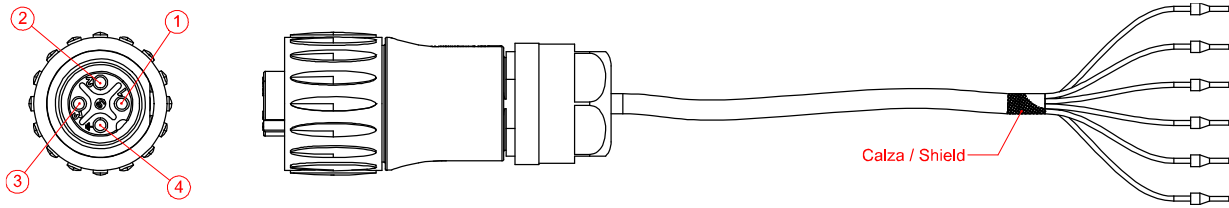

6 pole cable x 0.22mmq						
Pin	1	2	3	4	4	4
Cable	Red	White	Green	Black+Shield	Brown	Blue
Segnale	Vcc	Temp. +4÷20 mA +0÷2 Vdc	RH% +4÷20 mA +0÷2 Vdc	GND	Temp. -4÷20 mA -0÷2 Vdc	RH% -4÷20 mA -0÷2 Vdc

N.B.: the 2 signal masses (brown and blue wires) must both be connected when the sensor is connected to a device that requires 2 distinct masses for the signals (for example galvanic insulators) otherwise only one wire can be connected as common mass of both signals.

RS485 Serial Output Cable (SMATRH-S)

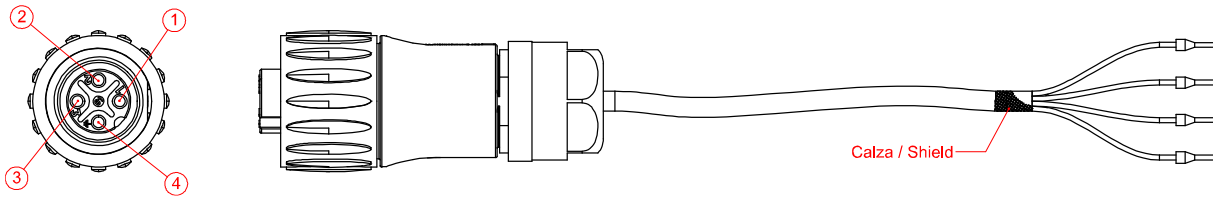

4 pole cable i x 0.22mmq				
Pin	1	2	3	4
Cable	Red	White	Green	Black+Shield
Signal	Vcc	B-RS485	A-RS485	GND

SDI-12 Serial Output Cable (SMATRH-12)

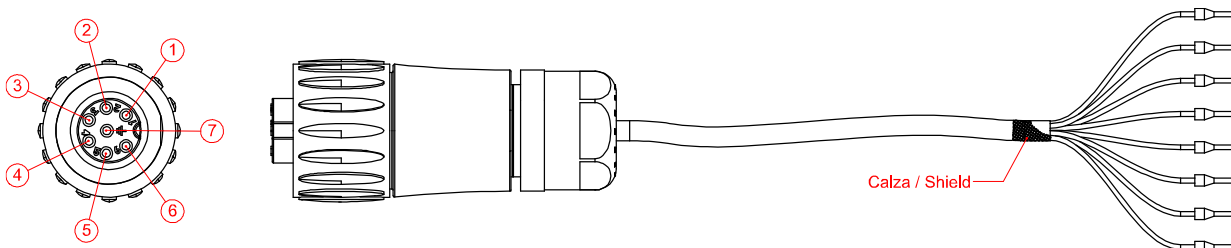

8 pole cable x 0.22mmq								
Pin	1	2	3	4	5	6	7	7
Cable	Red	White	Green	Black	Orange	Yellow	Blue	Brown
Signal	A-RS485	B-RS485	SDI-12 Data	-	-	SDI-12 Vcc	SDI-12 GND	GND

4.3 Data reading in serial (RS485 Modbus and SDI-12)

Sensors with RS485 Modbus or SDI-12 output send data only upon specific request from the PC, data logger or PLC.

Below are the correct communication parameters of the device performing the interrogation.

4.3.1 RS485 Modbus mode

Serial port settings: 9600 baud, no parity, 8 data bit, 1 bit di stop

Compatible with ModBus RTU protocol, functions supported: "03 – read Holding Registers" e "04 – Read Input Registers".

Data type: "2 registers swapped float IEEE 754 in the form CDAB where A is the most significant byte of the float and D is the less significant byte of the float (swapped float)".

ID	Registers	Units	Reg. 1-2	Reg. 3-4	Reg. 5-6	Reg. 7-8	Reg. 9-10	Reg. 11-12	Reg. 13-14
3	1	°C	Temperature	Relative Humidity	Dew Point	Frost Point	-	Diagnostic	Supply Voltage
	3	%					-		
	5	°C					-		
	7	°C					-		

4.3.2 SDI-12 mode

Serial port settings: 1200 baud, even parity, 7 data bit, 1 bit di stop

Supported commands (a = 3, sensor address)

?! Address Query

a! Send Identification

aM! Start Measurement

aC! Start Concurrent Measurement

aD0! Send Data

a	Position	Units	Decimals	Position 1	Position 2	Position 3	Position 4	Position 5	Position 6	Position 7
3	1	°C	2	Temperature	Relative Humidity	Dew Point	Frost Point	Diagnostic	Supply Voltage	-
	2	%	0							-
	3	°C	2							-
	4	°C	2							-

5 Generic information

The qualitative level of our instruments is the result of a continuous evolution of the product. This may cause differences between what is reported in the manual and the instrument you have purchased.

Siap+Micros S.p.A. reserves the right to modify without notice technical specifications and dimensions to adapt them to the needs of the product.

5.1 Safety

Please read these safety instructions carefully before using this product:

- The warranty will be void if the product is used differently from the instructions described in this manual.
- Any sign of tampering will void the warranty
- Use the devices only according to the instructions (environmental management, operation, wiring, installation, etc.) provided in this manual
- The correct and safe operation of the device can only be guaranteed if the transport, storage, operation and management of the device are compliant. This also applies to product maintenance.
- The device shall not be exposed to aggressive chemicals or solvents that could damage the plastic casing and/or corrode the metal parts.
- Maintenance should only be performed by qualified and well trained personnel.

It is appropriate to carry out a careful risk assessment in relation to the context of installation and use of the device by the installer considering the possible meteorological station in its complexity without being limited to the sensor.

The instruments must be installed according to the rules of the trade, with equipment that complies with applicable regulations and using supports correctly sized by qualified technicians and designed for the specific purpose.

During installation operations, check the suitability of the surrounding environment and compliance with local safety regulations.

The manufacturer declines all responsibility in case of failure due to negligence of the instructions, tampering, uses not described in this manual, improper use, use by operators not trained.

Read the instructions and intended use carefully and be sure you understand before installing the device

Before starting the activities, check the integrity of the instrument to be installed, prepare the equipment necessary for the work and wear the necessary PPE.

Take adequate measures to prevent the access of foreign personnel (untrained and uninformed) during the installation, maintenance or replacement of the instrument.

Take precautions to avoid falling objects, both during the installation phases and during the operation of the instrument.

Do not perform any activity in bad weather conditions.

During maintenance, particularly if the station is not frequented, visually check for the absence of dangerous insects and, if not, use suitable insecticides.

Consider the presence of any animals near the station, if so, pay attention to them.

Use only SIAP+MICROS original spare parts

The instrument is not classified suitable (according to Directive 2014/34/EU) for use in atmospheres with potential explosion risk pursuant to Directive 99/92/EC.

SIAP+MICROS strives to minimize health and safety risks in all phases of the instrument's life, including installation, use, maintenance, decommissioning and disposal.

5.2 Appropriate use of the equipment

Use the instrument for its intended purpose, do not use it for any other purpose or cause malfunctions and/or damage.

5.3 Storage

If you do not plan to use the equipment for an extended period of time (at least one year) disconnect all cables from the equipment, place it in a clear plastic bag along with a bag of desiccant salts and seal the bag with tape. Put appropriate indication on the bag of the contents and weight of the equipment by inserting the wording "HANDLE WITH CARE".

Store the instrument in an environment with a temperature between 0°C and 60°C with a humidity not exceeding 80%. Make sure that the instrument is stored in a stable position and that it cannot be damaged or moved by inexperience or carelessness. Do not stack other tools or weights. Do not place the instrument on top of other instruments and in any case ensure the solidity and stability of the underlying support.

Non esporre, stoccare lo strumento in ambienti con presenza di vapori e/o gas corrosivi.

5.4 Moving

In order to avoid any damage to the device during transportation, please keep it in upright position without shaking.

5.5 Disposal information



Electrical and electronic equipment marked with specific symbol in compliance with 2012/19/EU Directive must be disposed of separately from household waste. European users can hand them over to the dealer or to the manufacturer when purchasing a new electrical and electronic equipment, or to a WEEE collection point designated by local authorities. Illegal disposal is punished by law.

Disposing of electrical and electronic equipment separately from normal waste helps to preserve natural resources and allows materials to be recycled in an environmentally friendly way without risks to human health.

6 Revision history

The following table shows the description of the changes made to this document.

Version	Date	Updates
1.0	07/05/2024	Current version of the document.

All the information content in this document are the current available at the printing phase. Siap+Micros S.p.A. reserve the rights to change the specifications without any advance notice