

## t031 TVV / t032 TVVR

Wind speed transducer



User Manual and maintenance

SIAP+MICROS

## Summary

1	Introduction .....	3
2	Technical characteristic.....	4
2.1	Operating principle.....	6
3	Installation and maintenance .....	7
3.1	Installation.....	7
3.2	Maintenance .....	7
4	Electrical connection .....	8
4.1	Connector pinout .....	8
4.2	Connection cable .....	9
4.3	Data reading in serial communication (RS485 Modbus and SDI-12).....	10
4.3.1	RS485 Modbus mode .....	10
4.3.2	SDI-12 mode .....	10
5	Generic information .....	11
5.1	Safety.....	11
5.2	Appropriate use of the device .....	12
5.3	Storage .....	12
5.4	Moving .....	12
5.5	Disposal information .....	12
6	Revision history .....	13
7	Declaration of Conformity .....	14

## 1 Introduction

---

TVV is composed of a rotating body connected to three conical shaped elements (cups), and it measures the wind speed exploiting the wind resistance to rotational movement of the cups. The rotating system is equipped with a six poles cylindrical magnet. A Hall effect sensor detects the rotary motion that generates in the meantime an impulse at the passage of each pole.

The dimensions of the cups and the lightness of their material have been thoroughly picked to achieve a very low mechanical inertia and, consequently, to ensure a high sensitivity of the measurement.

The structure of TVV is very robust and the sensing element has a reliable durability and a proper resistance even at high wind speeds. Furthermore, its simple and compact design facilitates the installation and makes easier the on-site maintenance activities.

The sensor is supplied with power and signal cable (12m), and it is available upon request on heated version, powered at 9 or 24V (alternating or direct current).

### Available models:

Natural output: .....	PSM-t031-TVV-N
Current, voltage and RS485-Modbus output: .....	PSM-t031a-TVV-IVS
SDI-12 serial output: .....	PSM-t031d-TVV12
Heated sensor with natural output: .....	PSM-t032-TVVR-N
Heated version, Current output: .....	PSM-t032a-TVVR-I
Heated version, Tension output: .....	PSM-t032b-TVVR-V
Heated version, serial output: .....	PSM-t032c-TVVR-S

## 2 Technical characteristic

<b>Measurement performance</b>			
Transducer	6-pole magnet and stabilized Hall effect sensor		
Measurement range	0.25 ÷ 65		
Accuracy	< 0.15 o 1% of the measured value		
Resolution	0.1		
<b>Operating conditions</b>			
Temperature	-40 ÷ 70 °C		
Humidity	0 ÷ 100 RH%		
<b>Outputs</b>			
Natural	Open drain output: VV measurement is given by the frequency f as following: $VV = f \text{ [Hz]} / 3.3676 \text{ [Hz/ m/s]} + 0.1881 \text{ [m/s]}$		
Currente	4 ÷ 20 mA ↔ 0 ÷ 65 m/s		
Voltage	0 ÷ 2 V ↔ 0 ÷ 65 m/s		
RS485 MODBUS	Wind speed [m/s]		
SDI-12	Wind speed [m/s]		
<b>Power supply and consumption</b>			
Voltage supply	7 ÷ 24 Vdc		
Consumption	Min	Typical	Massimo
Natural		2.5	
4 ÷ 20 mA	5		25
0 ÷ 2 V / RS485 MODBUS / SDI-12		1	3
Heating system power	40 W @ 24 V		
<b>Mechanical specifications</b>			
Housing	Cups: PA6 + 30% fiberglass, the entire body is made of aluminium alloy and stainless steel screws		
Connector	IP67 / 7 pole male connector		

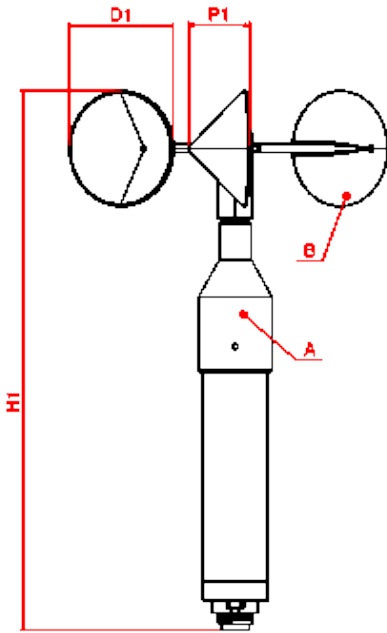

**Dimensions:**

H1 - maximum: ~ 336 mm

P1 – depth cup: 35 mm

D1 - cup diameter: 70 mm

Di1 - maximum diameter: 228 mm

**Sensor parts:**

A – Anodized aluminum body

B – Cups in nylon (PA6 + 30% glass fiber)

C – Stem  $\varnothing$ 40mm

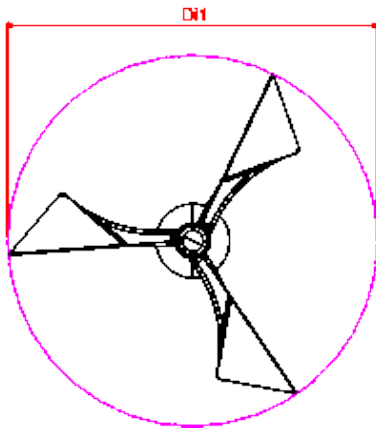

**Weight:** 750 g

## 2.1 Operating principle

The 3 cups at the top of the sensor rotate clockwise. When the wind blows the movement is transmitted by a steel shaft inside the sensor body, on the end of the shaft a 6-pole magnet is fixed, which rotates together with the shaft. The rotation of the magnet is detected by a Hall effect sensor generating a pulse. In the version provided with the frequency output the impulse is brought directly to the connector. In the other versions, an electronic interface carries the other different types of output to the connector. In the heated version (only with frequency output) the heating is achieved with power resistances inserted directly into the aluminum body and powered externally.

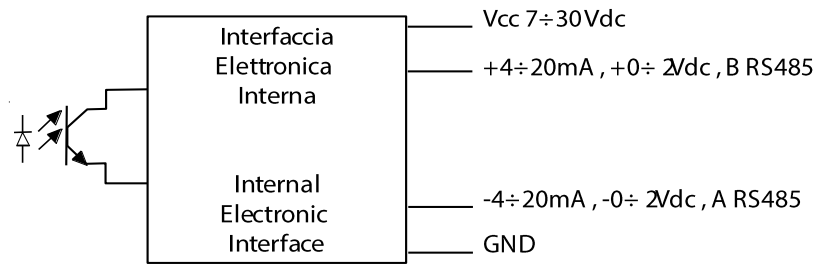

TVV-IVS / TVV-IV/S with a 4÷20mA, 0÷2Vdc, RS485 output

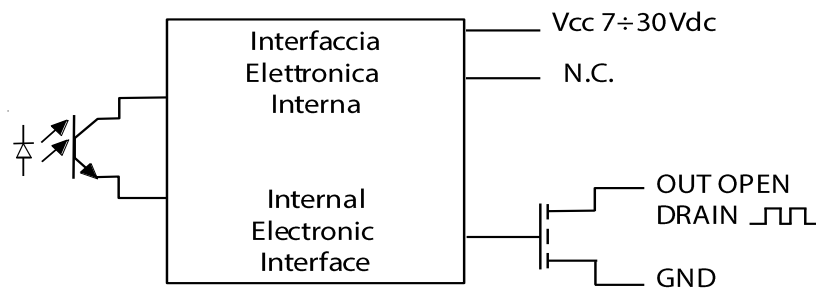

TVV-N / TVVR-N with frequency output

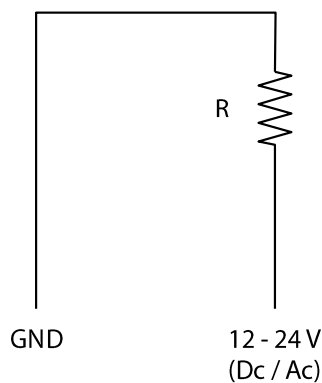

TVVR-X heated

## 3 Installation and maintenance

---

### 3.1 Installation

---

Before installing the sensor, unpack it from the package and assemble it by screwing the upper part (with the 3 cups) on the sensor body until it is completely blocked.

To install a meteorological station, it is necessary to pay attention to the characteristics of the site since the conformation of the ground and the proximity to possible obstacles can have influence on the quality of the data we want to acquire. It's important to know that any vertical obstacle as for instance trees and buildings, create a turbulence of air equal to ten times their height. For example, a meteorological station must be installed 100 meters away from any obstacles tall 10 meters height.

The TVV transducer is normally positioned (according to WMO standards) at a height of about 10 meters from the ground level. Normally, in Siap+Micros weather stations, it is installed with brackets equipped with 40mm diameter U-bolts (sensor stem diameter) fixed to the pole.

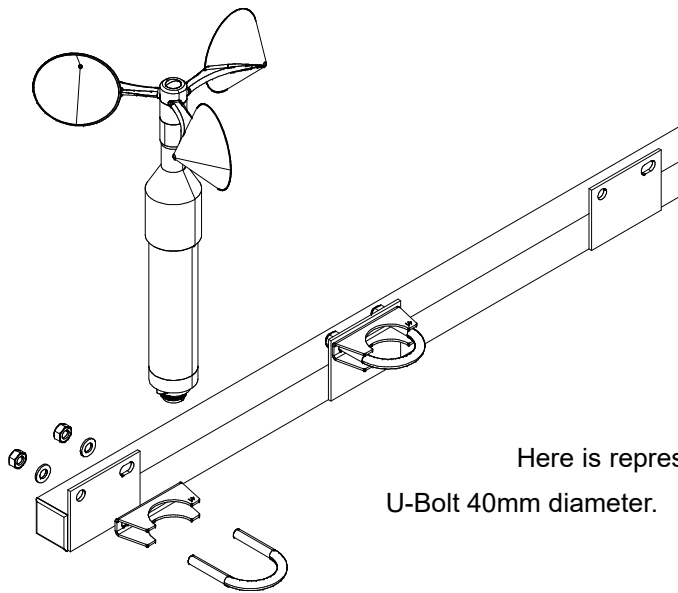
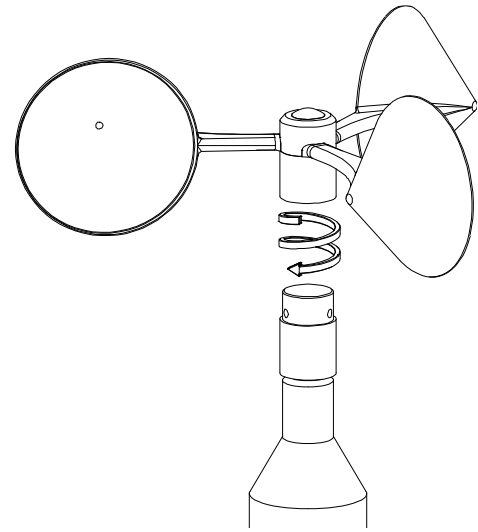

Here is represented a typical installation of the sensor using a U-Bolt 40mm diameter.

### 3.2 Maintenance

---

The transducer does not require ordinary maintenance, but it is recommended to periodically check the proper functioning of the internal bearings that are not seized. This operation is carried out by rotating the cups by hand checking that the movement is uniform and sensitive. Otherwise it is recommended to replace the sensor and go for a factory check.

## 4 Electrical connection

### 4.1 Connector pinout

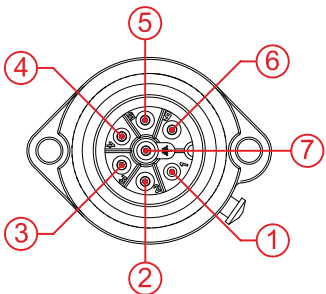
	Pin	Natural output	IVS output	SDI-12 output	Heated v. natural output	Heated v. IVS output
	1	Vcc	A-RS485	A-RS485	A-RS485	Vcc
2	OUT OPEN DRAIN	B-RS485	B-RS485	B-RS485	OUT OPEN DRAIN	+ 4÷20 mA / + sign. / A
3	n.c.	+0÷2 Vdc	SDI-12 (data)	n.c.	- 4÷20 mA / - sign. / B	
4	GND	+4÷20 mA	+4÷20 mA	GND	GND	GND
5	n.c.	-4÷20 mA -0÷2 Vdc	-4÷20 mA	n.c.	n.c.	n.c.
6	n.c.	Vcc	SDI-12 (Vcc)	V Risc	V Risc	V Risc
7	n.c.	GND	GND	V Risc	V Risc	V Risc

## 4.2 Connection cable

The connection cables supplied with the sensors are made with circular connectors with housing, 8 x 0.22 mmq cable (N, IVS and SDI-12 versions) or 6 x 0.22 mmq + 2 x 2.5 mmq (in the heated version), shielded and ferrules for connection to the data logger terminals. The shield is connected to the general ground lead.

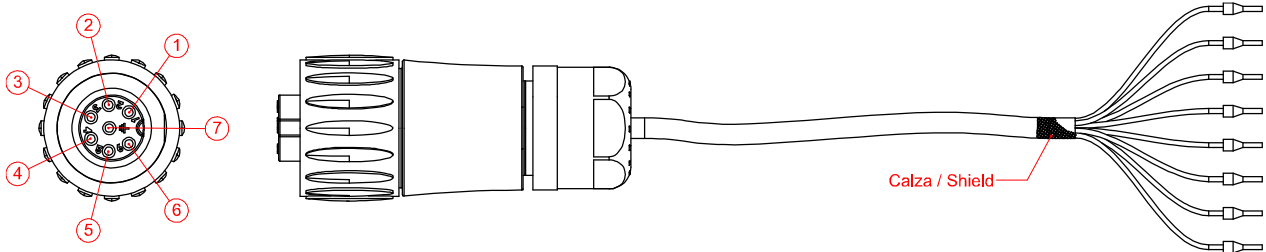

8 poles cable (8x0.22 mmq)								
Pin	1	2	3	4	5	6	7	7
Cable	Red	White	Green	Black	Orange	Yellow	Blue	Brown
TVV-N	Vcc (supply)	OUT OPEN DRAIN	n.c.	GND (supply)	n.c.	n.c.	n.c.	n.c.
TVV-IVS	A-RS485	B-RS485	+0÷2 Vdc	+4÷20 mA	-0÷2 Vdc -4÷20 mA	Vcc	GND	GND
TVV-12	A-RS485	B-RS485	SDI-12 (Data)	+4÷20 mA	-0÷2 Vdc	SDI-12 (Vcc)	GND	GND

6 poles cable 0.22 mmq + 2 poles 2.5 mmq								
Pin	1	2	3	4	5	6	7	7
Cable	Blue	White	Green	Black	Yellow	Blue (2.5mmq)	Brown (2.5mmq)	Red
TVVR-N	Vcc (sign.)	OUT OPEN DRAIN	n.c.	GND (sign.)	n.c.	V Risc	V Risc	GND
TVVR-IVS	Vcc (sign.)	+ 4÷20 mA / + sign. / A	- 4÷20 mA / - sign. / B	GND (sign.)	n.c.	V Risc	V Risc	GND

### 4.3 Data reading in serial communication (RS485 Modbus and SDI-12)

Sensors with RS485 Modbus or SDI-12 output send data only upon specific request from the PC, data logger or PLC.

The correct communication parameters of the device performing the data retrieve are shown below..

#### 4.3.1 RS485 Modbus mode

COM setting: 9600 baud, no parity, 8 data bit, 1 bit di stop.

Compliant with ModBus RTU protocol, function supported: "03 – read Holding Registers" e "04 – Read Input Registers".

Data type: "2 registers swapped float IEEE 754 in the form CDAB where A is the most significant byte of the float and D is the less significant byte of the float (swapped float)".

ID	Registers	Units	Reg. 1-2	Reg. 3-4	Reg. 5-6	Reg. 7-8	Reg. 9-10	Reg. 11-12	Reg. 13-14
1	1	m/s	Wind Speed	-	-	-	-	Diagnostic	Supply Voltage

#### 4.3.2 SDI-12 mode

COM settings: 1200 baud, even parity, 7 data bit, 1 bit di stop.

Supported commands (a = sensor adress):

?! address query

a! ID submission

aM! measurement start

aC! simultaneous measurement start

aD0! data send

a	Position	Units	Decimals	Position 1	Position 2	Position 3	Position 4	Position 5	Position 6	Position 7
1	1	m/s	1	Wind Speed	Diagnostic	Supply Voltage	-	-	-	-

## 5 Generic information

---

The qualitative level of our instruments is the result of a continuous evolution of the product. This may cause slight differences between what is reported in the manual and the instrument you have purchased.

Siap+Micros S.p.A. reserves the right to modify without notice technical specifications and dimensions to adapt them to the needs of the product.

### 5.1 Safety

---

Please read these safety instructions carefully before using this product:

- The warranty will be void in the case the product is used differently from the instructions described in this manual.
- Any sign of tampering will void the warranty
- Use the devices only according to the instructions (environmental management, operation, wiring, installation, etc.) provided in this manual
- The correct and safe operation of the device can only be guaranteed if the transport, storage, operation and management of the device are properly performed. This also applies to the product maintenance.
- The device shall not be exposed to aggressive chemicals or solvents that could damage the plastic casing and/or corrode the metal parts.
- Maintenance should only be performed by qualified and well trained personnel.

It is appropriate to carry out a careful risk assessment in relation to the context of installation and use of the device by the end user considering the entire meteorological station without being limited to the sensor.

The instruments must be installed properly, making sure that the equipment complies with the applicable regulations, the bracket must be correctly sized by qualified technicians and designed for the specific application.

During the installation the suitability of the surrounding environment and compliance with local safety regulations must be checked.

The manufacturer declines all responsibility in case of failure due to negligence of the instructions, tampering, uses not described in this manual, improper use, use by operators not trained.

Read the instructions and intended use carefully and be sure you understand before installing the device

Before starting the activities, check the integrity of the instrument to be installed, prepare the equipment necessary for the operations and wear the necessary PPE.

Take adequate measures to prevent the access of foreign personnel (untrained and uninformed) during the installation, maintenance or replacement of the instrument.

Take precautions to avoid falling objects, both during the installation phases and during the operation of the instrument.

Do not perform any activity in bad weather conditions.

During maintenance, specifically in case the station is not frequently visited, visually check for the absence of dangerous insects and, if not, use suitable insecticides.

Consider the presence of any animals near the station. If so, pay attention to them.

Use only SIAP+MICROS original spare parts.

The instrument is not classified suitable (according to Directive 2014/34/EU) for use in atmospheres with potential explosion risk pursuant to Directive 99/92/EC.

SIAP+MICROS strives to minimize health and safety risks in all phases of the instrument's life, including installation, use, maintenance, decommissioning and disposal.

## 5.2 Appropriate use of the device

---

Use the instrument for its intended purpose, do not use it for any other purpose or cause malfunctions and/or damage.

## 5.3 Storage

---

If you do not plan to use the equipment for an extended period of time (at least one year) disconnect all cables from the equipment, place them in a clear plastic bag along with a bag of desiccant salts and seal the bag with tape. Put appropriate indication on the bag of the contents and weight of the equipment by inserting the wording "HANDLE WITH CARE".

The instrument must be stored in a protected environment with a temperature between 0°C and 60°C with a humidity not exceeding 80%. Make sure that the instrument is stored in a stable position and that it cannot be damaged or moved by inexperience or carelessness. Do not stack other tools or weights. Do not place the instrument on top of other instruments and in any case ensure the solidity and stability of the underlying support.

Do not display and stock the instrument in environments where corrosive gas may be present.

## 5.4 Moving

---

In order to avoid any damage to the device during transportation, please keep it in upright position without shaking.

## 5.5 Disposal information

---



Electrical and electronic equipment marked with specific symbol in compliance with 2012/19/EU Directive must be disposed of separately from household waste. European users can hand them over to the dealer or to the manufacturer when purchasing a new electrical and electronic equipment, or to a WEEE collection point designated by local authorities. Illegal disposal is punished by law.

Disposing of electrical and electronic equipment separately from normal waste helps to preserve natural resources and allows materials to be recycled in an environmentally friendly way without risks to human health.

## **6 Revision history**

---

The following table shows the description of the changes made to this document.

<b>Version</b>	<b>Data</b>	<b>Aggiornamenti</b>
1.0	31/01/2025	<i>First version of the document.</i>

All the information content in this document are the current available at the printing phase. Siap+Micros S.p.A. reserve the rights to change the specifications without any advance notice.

## 7 Declaration of Conformity



MD 751.1 rev. 03

### EU Declaration of Conformity (DoC)

**Manufacturer:** SIAP+MICROS S.p.A.  
 Via del Lavoro, 1 – 31020 S. Fior (TV) – Italy  
<https://www.siapmicros.com/en/>

This declaration of conformity is issued under the sole responsibility of the manufacturer.

**Object of the declaration:**

Description	Product Code/Model
TVV-IVS Outdoor Air Temperature Transducer with voltage output	PSM-t031a-TVV-IVS

The object of the declaration described above is in conformity with the relevant Union harmonization legislation:

- 2014/30/EU Electromagnetic Compatibility (EMC)
- 2011/65/EU The Restriction of Hazardous Substances Directive (RoHSD)

The following harmonised standards and technical specifications have been applied:

**EMC references:**

<b>EN 61326-1</b> 2021-06	Electrical equipment for measurement, control and laboratory use - EMC requirements - General requirements
------------------------------	--

**RoHSD references:**

<b>EN 63000</b> 2016+AMD1:2022	Technical documentation for the assessment of electrical and electronic products with respect to the restriction of hazardous substances
-----------------------------------	--

**Date**  
 31-01-2023

**CEO**  
 Alex Stevanin

