

## t035a Winson 4

### Ultrasound anemometers



User manual

SIAP+MICROS

## *Index*

---

1	Introduction .....	3
2	Technical specification .....	4
3	Measuring principle of wind speed and direction .....	5
4	Installation.....	6
4.1	Alignment of the instrument .....	7
4.2	Electrical connections.....	8
4.2.1	RS232 serial connection .....	9
4.2.2	RS485 serial connection .....	9
4.2.3	Connection of RS52 cable.....	10
5	Configuration.....	11
5.1	Serial commands.....	11
6	MODBUS-RTU mode .....	14
7	Instrument storage .....	15
8	Safety instructions .....	16
9	Ordering codes.....	17
10	History of revisions .....	18

## **1 Introduction**

---

**T035** is a series of 2-axis Ultrasound static anemometers for the measurement of:

- Wind speed and direction
- U-V Cartesian components of wind speed
- Wind Gust

The average of wind speed and direction over a period configurable up to 10 minutes is calculated.

Wind speed and direction are determined by measuring the transit time of Ultrasound pulses between two pairs of Ultrasound transducers.

**t035a** has RS485 MODBUS-RTU output.

All models are equipped with a magnetic compass.

Mounting on  $\varnothing$  40 mm mast. The electric connection is performed through a M23 19-pole connector situated on the bottom of the instrument.

The low power consumption of the instrument allows installation in remote sites, with power supplied by photovoltaic panel and backup battery.

The absence of moving parts minimizes the instrument maintenance.

## 2 Technical specification

<b>Wind speed</b>	
Used sensor	Ultrasound
Measuring range	0÷60 m/s
Resolution	0,01 m/s
Accuracy	± 0.2 m/s or ± 2%, whichever is greater (0...35 m/s), ± 3% (> 35 m/s)
<b>Wind direction</b>	
Used sensor	Ultrasound
Measuring range	0÷359.9°
Resolution	0,1°
Accuracy	± 2° RMSE from 1.0 m/s
<b>Compass</b>	
Sensor	Ultrasound
Measuring range	0÷360°
Resolution	0.1°
Accuracy	± 1°
<b>General features</b>	
Power Supply	10÷30 Vdc
Power consumption	26 mA @ 12 Vdc
Digital output	RS485 MODBUS-RTU
Averaging interval	Configurable from 1 s to 10 min
Electrical connection	M23 connector
Operating temperature	-40 ÷ +60 °C
Survival speed	90 m/s
Protection degree	IP 66
Dimensions	H=179 mm, ø=150 mm
Weight	640 g ca.
Case	ASA. AISI316 metallic parts

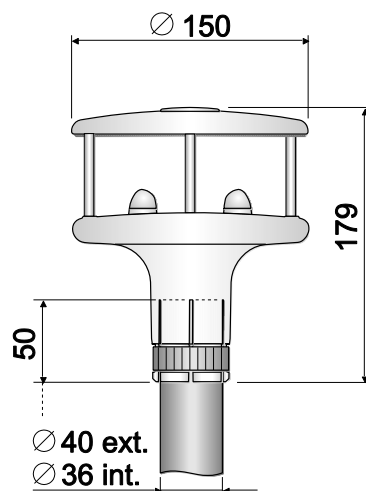

### 3 **Measuring principle of wind speed and direction**

Wind speed and direction are determined by measuring the time taken by Ultrasound pulses to cover the distance from the transducer that generates the pulse to the receiving transducer.

The instrument uses 2 pairs of transducers oriented along two orthogonal axes. Detecting the wind speed along two axes allows determining not only the intensity but also the wind direction.

The instrument measures the travel time of the Ultrasound pulse between the two transducers of the same pair in both directions. The travel times in the two opposed directions are defined as  $t_A$  (forward direction time) and  $t_R$  (reverse direction time).

If wind speed is zero,  $t_A$  and  $t_R$  values are the same. In the presence of wind, one of the two-time values is greater than the other and the comparison between the two-time values allows to determine the direction and the intensity of the wind.

Measuring the travel time in both directions allows to cancel the dependence of the transmission speed of ultrasounds in the air from the environmental conditions of temperature, humidity and barometric pressure.

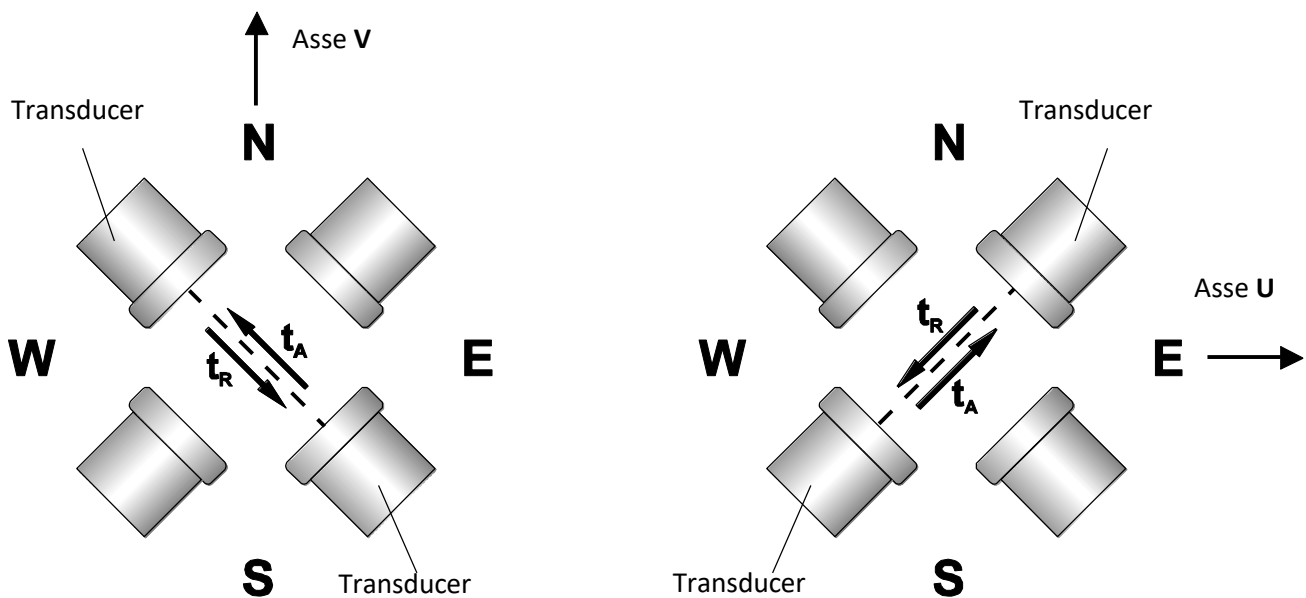

**Measurement along first axis**

**Measurement along second axis**

The travel times of the Ultrasound pulses are given by:

$$t_A = \frac{D}{C + V_w}$$

$$t_R = \frac{D}{C - V_w}$$

Where:

- D** = Distance between the two transducers of the same pair
- C** = Sound speed
- V<sub>w</sub>** = Component of wind speed along the measurement axis

Measuring the two travel times allows determining the wind speed component:

$$V_w = \frac{D}{2} \cdot \left( \frac{1}{t_A} - \frac{1}{t_R} \right)$$

## 4 Installation

To install the instrument, pass the connection cable inside the support mast and connect the 19-pole M23 female connector of the cable to the 19-pole M23 male connector situated at the bottom of the instrument. Ensure connection stability by tightening the connector external nut.

Align the arrow on the housing of the instrument to the North (see par. **Errore. L'origine riferimento non è stata trovata.** "Alignment"), then fix it on the support mast by tightening the cable tie at the bottom of the instrument.

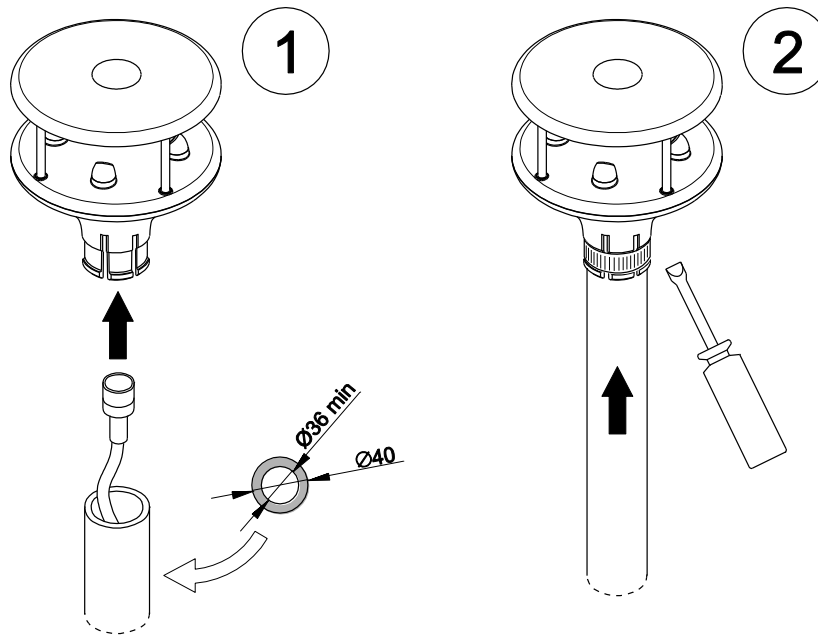

The support mast, having 40 mm maximum outer diameter and 36 mm minimum inner diameter, should be positioned on a stable surface.

The instrument should be installed vertically and in an open area, far from obstructions located in the vicinity that might alter the natural air flow. Any close objects (such as buildings, trees, pylons, etc.) should be at a distance equal to at least ten times their height.

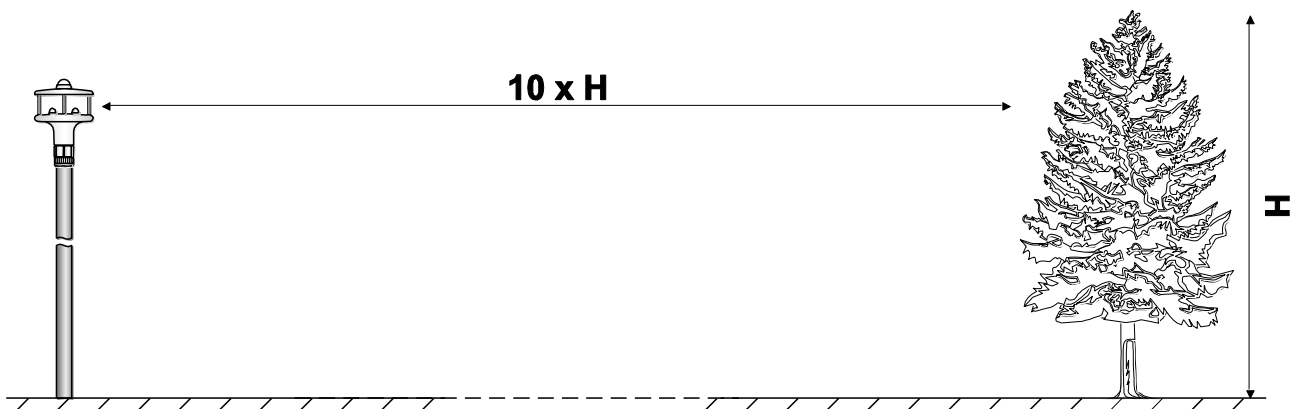

In the presence of close objects, it is advisable to place the instrument at a height of 10 m.

If the instrument is installed on a building, the height of the instrument should be at least 1.5 times the minimum value between the height of the building and the roof longest diagonal.

Mount the instrument far from magnetic materials and devices that generate magnetic fields (electric motors, electric power cables, electric transformers, radars, radio transmitters etc.) in order to prevent faulty indications from the magnetic compass.

In case of mobile installations (for example on a boat), take into account that the instrument measures the relative (apparent) wind speed with respect to the instrument. To determine the absolute (real) wind speed one should consider the movement velocity of the instrument.

The instrument is factory-calibrated and does not require additional interventions of the user.

For the available configuration parameters, the related factory settings and the commands to modify the parameters, see Chapter 5 "CONFIGURATION".

In the model T035A, the RS485 MODBUS-RTU mode will be active 10 seconds after power up.

#### 4.1 Alignment of the instrument

The instrument is equipped with a magnetic compass, and wind speed and direction measurements are automatically compensated and referred to magnetic North, even if alignment to North is not performed. This allows obtaining accurate measurements even in case of mobile installations.

It is possible to disable the compass compensation of the wind speed and direction measurements. In this case it is necessary to align the instrument during installation. The arrows on the case will facilitate the alignment.

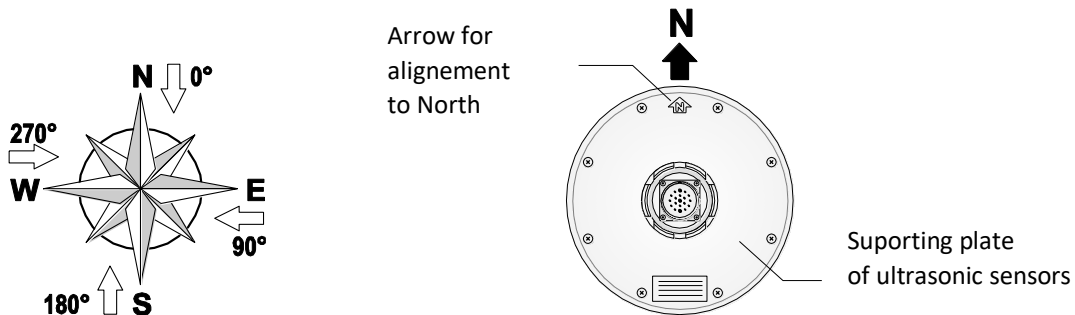

For an accurate alignment, connect the instrument to a PC (see following chapters for communication protocols), then rotate the instrument on its vertical axis until the compass measures  $0.0^\circ \pm 0.1^\circ$ .

When evaluating the wind direction, one should take into account that the geographic North differs from the magnetic North indicated by a magnetic compass. The difference, named **magnetic declination**, depends on the area where the instrument was installed (for example, about  $15^\circ$  in North-America and less than  $3^\circ$  in Europe).

If wind speed and direction values are given in polar coordinates,  $0^\circ$  angle corresponds to a wind coming from North.

## 4.2 Electrical connections

All connections are performed through a 19-pole M23 male connector situated at the bottom of the instrument. The figure and the table below show numbers and function of the connector contacts and the corresponding wires of the **p041p** optional cable:

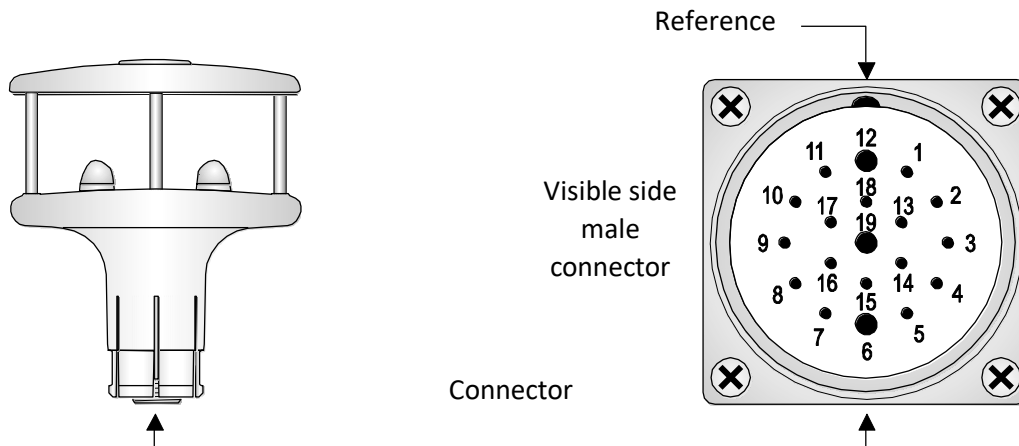

Connector pin N°	p041p cable wire color	Symbol	Description
1			Not connected
2			Not connected
3	Violet	RX +	RX for RS232 connection
4			Not connected
5			Not connected
6			Not connected
7			Not connected
8	Blue	GND	Serial ground
9	Red	TX -	DATA - for RS485 connection TX for RS232 connection
10			Not connected
11			Not connected
12	Black	GND	Instrument power supply negative
13			Not connected
14	Yellow		Not connected
15	Green		Not connected
16	Orange		Not connected
17	Brown	TX +	DATA + for RS485 connection
18		V +	Instrument power supply positive (10÷30 Vdc)
19	White	V +	Instrument power supply positive (10÷30 Vdc)
--	Grey	SHIELD	Cable shield

### 4.2.1 RS232 serial connection

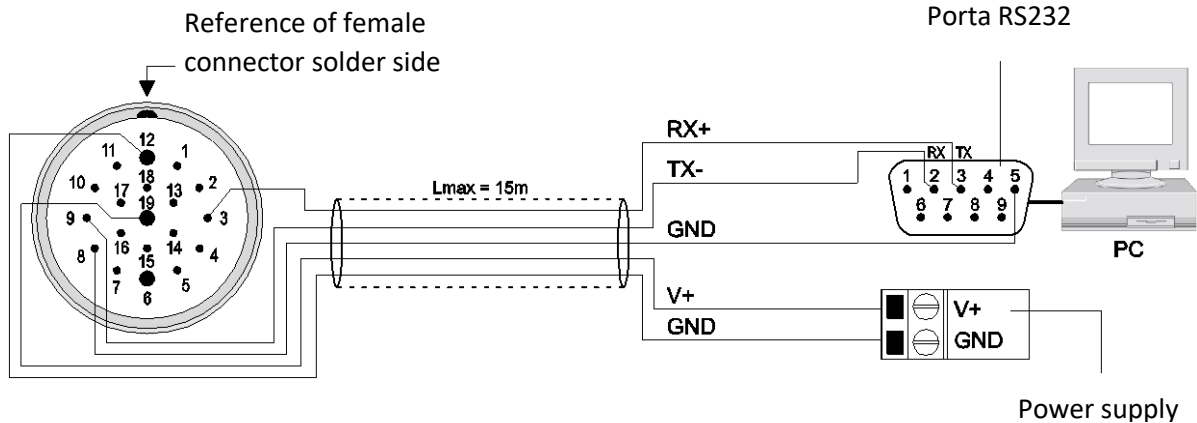

For RS232 connection, TX-, RX+ and serial GND signals (pin 9, 3 and 8 of M23 connector) are used, to be connected respectively to RX, TX and GND signals of RS232 port on PC (pin 2, 3 and 5 of 9-pole SubD connector). The length of RS232 cables should not exceed 15 m.

The RS232 serial connection is used for the instrument configuration (via serial commands or software) and for displaying the measurements in real time (via software).

If the PC is not equipped with RS232 serial ports, the **RS52** adapting cable (with built-in USB/RS232 converter) can be inserted between the PC and the instrument (see paragraph **Errore. L'origine riferimento non è stata trovata.**).

### 4.2.2 RS485 serial connection

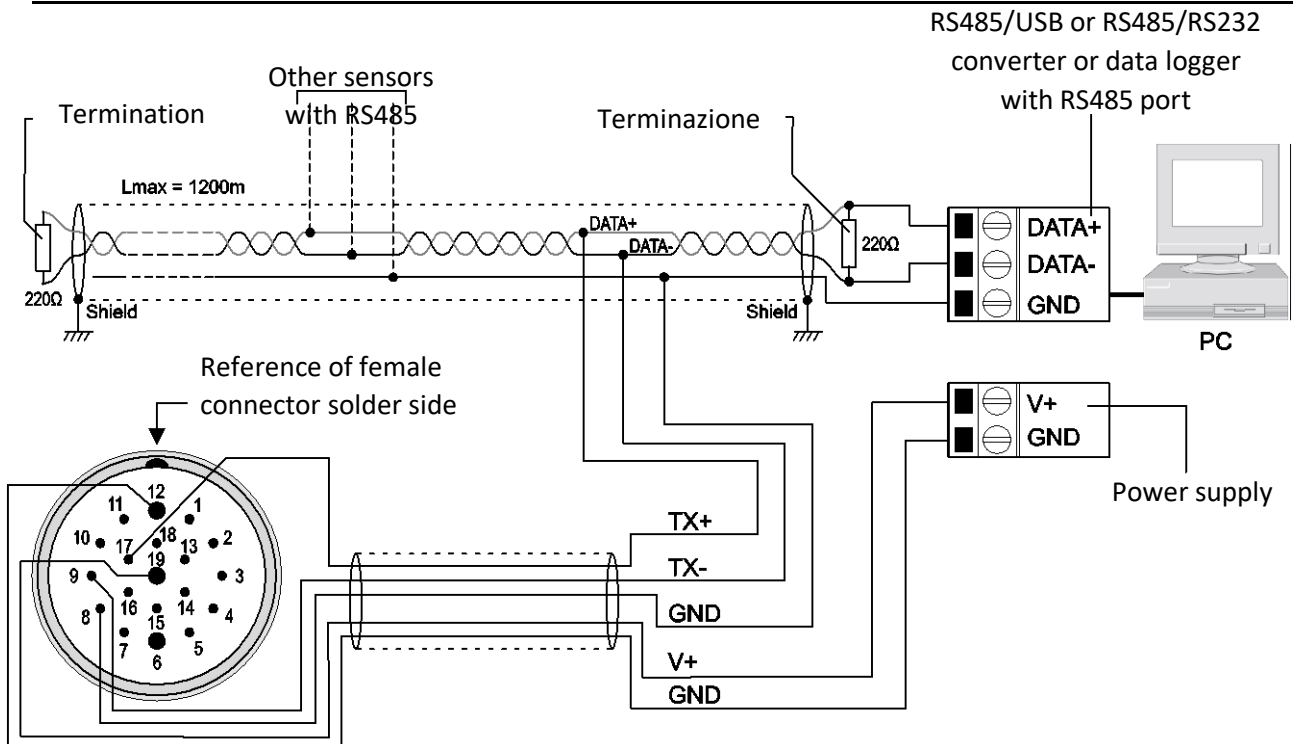

Thanks to RS485 connection, multiple instruments can be connected to a multi-point network. Instruments are connected in sequence through a twisted-pair shielded cable for signals and a third wire for ground.

Line terminations should be placed at the two ends of the network. The cable shield should be connected to both ends of the line.

The maximum number of devices that can be connected to the RS485 line (Bus) depends on the load characteristics of the devices to be connected. The RS485 standard requires that the total load does not exceed 32 unit loads. The load of an HD52.3D+ anemometer is equal to 1/4 of unit load. If the total load is greater than 32 unit loads, divide the network into segments and add a signal repeater between a segment and the successive one. Line termination should be applied at both ends of each segment.

The maximum length of the cable depends on the transmission speed and the cable characteristics. Typically, the maximum length is 1200 m. The data line should be kept separated from any power lines in order to prevent interference with the transmitted signal.

Each instrument on the network is univocally identified by an address. Multiple transmitters with the same address should not be placed on the network.

If the instrument is connected to a data logger, the possibility to connect multiple sensors to the network depends on the data logger capacity to manage multiple sensors.

MODBUS-RTU protocol is used with RS485 connection.

Before connecting the instrument to the network, configure address and Baud Rate (see chapter 5 "CONFIGURATION").

### 4.2.3 Connection of RS52 cable

If the PC is not equipped with RS232 serial ports, but with USB ports only, the **RS52** adapting cable (with built-in USB/RS232 converter) should be interposed between the PC and the instrument.

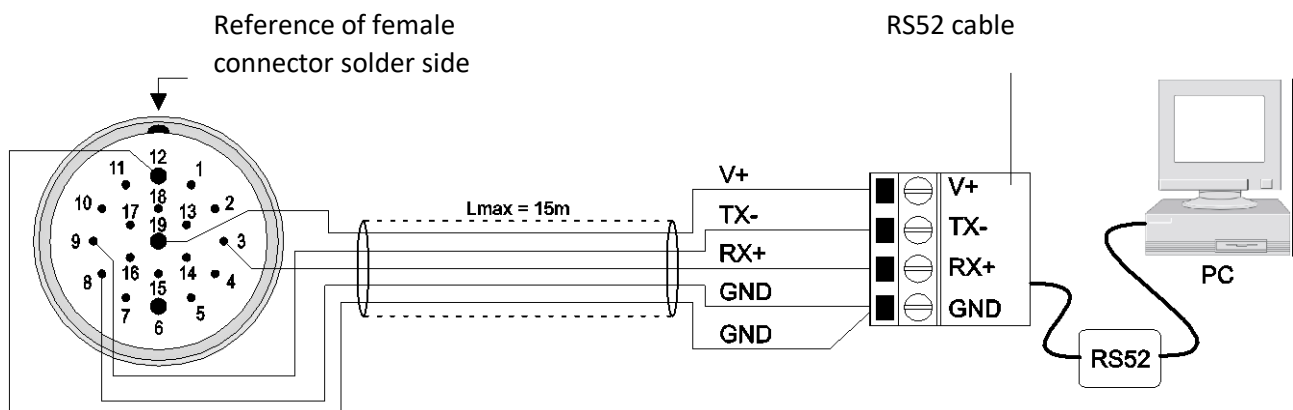

To use the **RS52** cable, the drivers included in the software package should be installed in the PC (see the guide to USB drivers installation included in the software package).

The instrument is powered directly from the USB port of the PC.

## 5 Configuration

Configuration mode allows to read the instrument general info (firmware version, calibration date, serial number), to read and set the instrument operation parameters.

To configure the instrument, a RS232 serial connection to a PC should be performed (see paragraph **Errore. L'origine riferimento non è stata trovata.**). If your PC is not equipped with RS232 serial ports, the **RS52** adapting cable can be placed between the PC and the instrument (see paragraph **Errore. L'origine riferimento non è stata trovata.**).

The instrument configuration can be realized with the aid of the application software (see the instructions of the software) or by sending serial commands via standard communication programs.

If a standard communication program is used, the program communication parameters should be set as follows:

- Baud rate: 115200
- Data Bits: 8
- Parity: None
- Stop Bit: 2

The serial output of the T035A is preset to operate in MODBUS-RTU mode; in order to enter configuration mode after connecting the instrument to the PC via RS232 it is necessary to send **within 10 seconds from power on** (if the instrument is already powered, power cycle the instrument) the serial command **@** (if a standard communication program is used) or the request of connection with the application software, if the application software is used.

To reset the serial output of the t035a model to MODBUS-RTU mode after the configuration has been carried out, power cycle the instrument: the MODBUS-RTU protocol will become active after 10 seconds from restart.

### 5.1 Serial commands

The tables below describe the serial commands that allow reading the current instrument configuration and change the operation parameters.

#### Informazioni sullo strumento:

Command	Reply	Description
G1	&Vnn.nn aaaa/mm/gg	Version and date of firmware
RGD	&aaaa/mm/gg hh.mm.ss	Date and time of calibration
RGS	&nnnnnnnn	Serial number of instrument
RGI	&ccc+ccc	User code
CGlccc+ccc	&	Sets user code to ccc+ccc (max. 34 characters)

## Parametri generali:

Comando	Risposta	Descrizione
CGUVn	&	Sets measuring unit of wind speed: <ul style="list-style-type: none"> <li>▪ m/s if n=1</li> <li>▪ cm/s if n=2</li> <li>▪ km/h if n=3</li> <li>▪ knot if n=4</li> <li>▪ mph if n=5</li> </ul> <p><i>Default</i> : m/s (n=1)</p>
RGUV	n	Reads the wind speed measuring unit set in the instrument
CWCnnnn	&	Sets wind speed threshold to nnnn value (in hundredths of m/s) Value should range within 0 and 100 hundredths of m/s (= 0÷1 m/s) <i>Default</i> : 20 (= 0.2 m/s) (see <b>Note 1</b> )
RWC	& nnnn	Reads the wind speed threshold value set in the instrument (in hundredths of m/s)
CWaLnnn	&	Sets time interval for the calculation of average speed and average direction to nnn value Value should range within 1 and 600 s. If the value is greater than 10 s, it must be an integer multiple of 10. <i>Default</i> : 1 s
RWaL	& nnn	Reads the time interval for the calculation of average speed and average direction set in the instrument
CWaMn	&	Sets the method for the calculation of average speed and average direction: <ul style="list-style-type: none"> <li>▪ If n=0: scalar mean. The average intensity is calculated as average of intensities without consideration of direction. The average direction is calculated as average of directions, and expressed according to the extended characteristic (see <b>Note 2</b>).</li> <li>▪ If n=1: vector mean. The average of the coordinates along each measurement axis is calculated. The average intensity and the average direction are those determined by the two average coordinates.</li> </ul> <p><i>Default</i> : vector mean (n=1)</p>
RWaM	& n	Reads the method for the calculation of the average speed and average direction set in the instrument
CCn	&	Enables/disables the compass compensation of wind speed and direction: <ul style="list-style-type: none"> <li>▪ Disables if n=N</li> <li>▪ Enables if n=Y</li> </ul> <p><i>Default</i>: Enabled (n=Y)</p>

### **Note 1 : Wind speed threshold value**

If the wind speed is very low, the determination of the direction can result inaccurate. The instrument allows setting the threshold value of speed below which the direction value is frozen on the last acquired value.

### Parameters for MODBUS-RTU mode:

Command	Reply	Description
CU5Annn	&	Sets MODBUS address to nnn The address should range within 1 and 247 <i>Default</i> : 1
RU5A	& nnn	Reads the MODBUS address setting
CU5Bn	&	Sets the Baud Rate for MODBUS mode to: <ul style="list-style-type: none"> <li>▪ 9600 if n=3</li> <li>▪ 19200 if n=4</li> <li>▪ 38400 if n=5</li> <li>▪ 57600 if n=6</li> <li>▪ 115200 if n=7</li> </ul> <i>Default</i> : 19200 (n=4)
RU5B	& n	Reads Baud Rate setting for MODBUS mode
CU5Mn	&	Sets parity and stop bits for MODBUS mode to: <ul style="list-style-type: none"> <li>▪ 8N1 if n=0 [No parity, 1 stop bit]</li> <li>▪ 8N2 if n=1 [No parity, 2 stop bits]</li> <li>▪ 8E1 if n=2 [Even parity, 1 stop bit]</li> <li>▪ 8E2 if n=3 [Even parity, 2 stop bits]</li> <li>▪ 8O1 if n=4 [Odd parity, 1 stop bit]</li> <li>▪ 8O2 if n=5 [Odd parity, 2 stop bits]</li> </ul> The number of bits is fixed to 8 <i>Default</i> : 8E1 (n=2)
RU5M	& n	Reads the setting of parity and stop bits for MODBUS mode
CU5Wn	&	Sets waiting time after transmission in MODBUS mode to: <ul style="list-style-type: none"> <li>▪ Immediate reception if n=0 (violates protocol)</li> <li>▪ Waiting 3.5 characters if n=1 (respects protocol)</li> </ul> <i>Default</i> : Waiting 3.5 characters (n=1)
RU5W	& n	Reads the setting of waiting time after transmission in MODBUS mode

## 6 MODBUS-RTU mode

In MODBUS-RTU mode, the instrument sends the acquired measurements only if specifically requested by the PC, PLC or data logger.

Communication parameters should be set in the PC or data logger as follows:

- Baud rate: same as the setting in the instrument (default = 19200)
- Data bits: 8
- Parity: same as the setting in the instrument (default = even)
- Stop bits: same as the setting in the instrument (default = 1)

Below is the list of registers.

### Input Registers

Indirizzo	Descrizione	Formato
0	Instantaneous wind speed (x100)	unsigned 16 bits
1	Instantaneous wind direction in degrees (x10)	unsigned 16 bits
8	Compass angle in degrees (x10)	Unsigned 16 bits
10	Average wind speed (x100)	unsigned 16 bits
11	Average wind direction in degrees (x10)	unsigned 16 bits
14	Wind direction in degrees (x10) with extended feature (see page <b>Errore. Il segnalibro non è definito.</b> )	unsigned 16 bits
15	Wind speed (x100) along V-axis	unsigned 16 bits
16	Wind speed (x100) along U-axis	unsigned 16 bits
17	Status register: bit0=1 ⇒ Speed measurement error	unsigned 16 bits
18	Wind speed unit of measurement 0 ⇒ m/s, 1 ⇒ cm/s, 2 ⇒ km/h, 3 ⇒ knot, 4 ⇒ mph	unsigned 16 bits
21	Wind Gust intensity (x100)	unsigned 16 bits
22	Wind Gust direction in degrees (x10)	unsigned 16 bits

*Note:* the wind speed measurement value is expressed in the unit set in the instrument.

The Wind Gust measurement is determined by continuously calculating the wind speed averages in a time interval equal to 3 seconds and detecting the maximum value of the calculated averages over the time elapsed between the current reading command and the previous reading command (the Wind Gust measurement is reset after each reading command).

## **7 Instrument storage**

---

Instrument storage conditions:

- Temperature: -40...+65 °C.
- Humidity: less than 90 %RH no condensation.
- In storing, avoid locations where:
  - There is a high humidity level.
  - The instrument is exposed to direct sunlight.
  - The instrument is exposed to a high temperature source.
  - There are high vibration levels.
  - There is presence of vapor, salt and/or corrosive gas.

## **8 Safety instructions**

---

### **General safety instructions**

The instrument has been manufactured and tested in accordance with the safety standard EN61010-1:2010 "Safety requirements for electrical equipment for measurement, control and laboratory use" and has left the factory in perfect safety technical conditions.

The instrument proper operation and operating safety can be ensured only if all standard safety measures as well as the specific measures described in this manual are followed.

The instrument proper operation and operating safety can be ensured only in the climatic conditions specified in this manual.

Do not use the instrument in places where there are:

- Rapid ambient temperature variations that may cause condensation.
- Corrosive or flammable gases.
- Direct vibrations or shocks to the instrument.
- High-intensity electromagnetic fields, static electricity.

If the instrument is moved from a cold place to a hot one, or vice versa, condensation formation can cause an instrument malfunction. In this case, you will have to wait for the instrument temperature to reach ambient temperature before turning the instrument on.

### **User obligations**

The instrument operator shall follow the directives and regulations below that refer to the treatment of dangerous materials:

- EEC directives on workplace safety
- National low regulations on workplace safety
- Accident prevention regulations

## **9 Ordering codes**

---

### **output:**

- **t035a** = RS485 Modbus – RTU

### **standard cables p041p:**

- **p041p-M23C10P04M**: 4m cable
- **p041p-M23C10P12M**: 12m cable

## 10 History of revisions

---

The following table shows the description of the changes made to this document.

<b>Version</b>	<b>Date</b>	<b>Update</b>
1.4	15/11/2024	First version of the document.

### TECHNICAL INFORMATION

The quality level of our instruments is the result of the continuous product development. This may lead to differences between the information reported in the manual and the instrument you have purchased.

Siap+Micros S.p.A. reserves the right to change technical specifications and dimensions to fit the product requirements without prior notice.

### DISPOSAL INFORMATION



Electrical and electronic equipment marked with specific symbol in compliance with 2012/19/EU Directive must be disposed of separately from household waste. European users can hand them over to the dealer or to the manufacturer when purchasing a new electrical and electronic equipment, or to a WEEE collection point designated by local authorities. Illegal disposal is punished by law.

Disposing of electrical and electronic equipment separately from normal waste helps to preserve natural resources and allows materials to be recycled in an environmentally friendly way without risks to human health.