

***t003m TRHTC***  
***Soil Moisture and Temperature Probe***

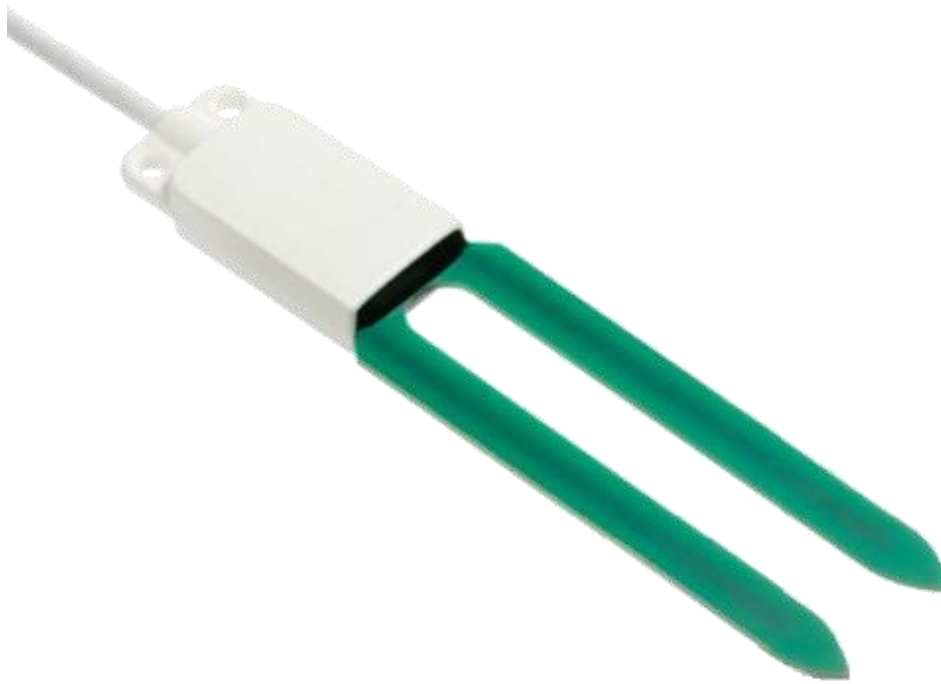

User Manual and maintenance

SIAP+MICROS

## Summary

1	Generic information .....	3
1.1	Safety.....	3
1.2	Appropriate use of the equipment .....	4
1.3	Storage .....	4
1.4	Moving .....	4
1.5	Disposal information .....	4
2	Introduction .....	5
2.1	Technical Specifications .....	5
2.2	Installation.....	6
2.3	Connections.....	7
2.3.1	Setting of RS485 communication parameters .....	8
2.3.2	Procedure for setting the parameters .....	8
2.3.3	Modalità ModBus .....	9
3	Revision history .....	10

## 1 Generic information

---

The qualitative level of our instruments is the result of a continuous evolution of the product. This may cause differences between what is reported in the manual and the instrument you have purchased.

Siap+Micros S.p.A. reserves the right to modify without notice technical specifications and dimensions to adapt them to the needs of the product.

### 1.1 Safety

---

Please read these safety instructions carefully before using this product:

- The warranty will be void if the product is used differently from the instructions described in this manual.
- Any sign of tampering will void the warranty
- Use the devices only according to the instructions (environmental management, operation, wiring, installation, etc.) provided in this manual
- The correct and safe operation of the device can only be guaranteed if the transport, storage, operation and management of the device are compliant. This also applies to product maintenance.
- The device shall not be exposed to aggressive chemicals or solvents that could damage the plastic casing and/or corrode the metal parts.
- Maintenance should only be performed by qualified and well trained personnel.

It is appropriate to carry out a careful risk assessment in relation to the context of installation and use of the device by the installer considering the possible meteorological station in its complexity without being limited to the sensor.

The instruments must be installed according to the rules of the trade, with equipment that complies with applicable regulations and using supports correctly sized by qualified technicians and designed for the specific purpose.

During installation operations, check the suitability of the surrounding environment and compliance with local safety regulations.

The manufacturer declines all responsibility in case of failure due to negligence of the instructions, tampering, uses not described in this manual, improper use, use by operators not trained.

Read the instructions and intended use carefully and be sure you understand before installing the device

Before starting the activities, check the integrity of the instrument to be installed, prepare the equipment necessary for the work and wear the necessary PPE.

Take adequate measures to prevent the access of foreign personnel (untrained and uninformed) during the installation, maintenance or replacement of the instrument.

Take precautions to avoid falling objects, both during the installation phases and during the operation of the instrument.

Do not perform any activity in bad weather conditions.

During maintenance, particularly if the station is not frequented, visually check for the absence of dangerous insects and, if not, use suitable insecticides.

Consider the presence of any animals near the station, if so, pay attention to them.

Use only SIAP+MICROS original spare parts

The instrument is not classified suitable (according to Directive 2014/34/EU) for use in atmospheres with potential explosion risk pursuant to Directive 99/92/EC.

SIAP+MICROS strives to minimize health and safety risks in all phases of the instrument's life, including installation, use, maintenance, decommissioning and disposal.

## 1.2 Appropriate use of the equipment

---

Use the instrument for its intended purpose, do not use it for any other purpose or cause malfunctions and/or damage.

## 1.3 Storage

---

If you do not plan to use the equipment for an extended period of time (at least one year) disconnect all cables from the equipment, place it in a clear plastic bag along with a bag of desiccant salts and seal the bag with tape. Put appropriate indication on the bag of the contents and weight of the equipment by inserting the wording "HANDLE WITH CARE".

Store the instrument in an environment with a temperature between 0°C and 60°C with a humidity not exceeding 80%. Make sure that the instrument is stored in a stable position and that it cannot be damaged or moved by inexperience or carelessness. Do not stack other tools or weights. Do not place the instrument on top of other instruments and in any case ensure the solidity and stability of the underlying support.

Non esporre, stoccare lo strumento in ambienti con presenza di vapori e/o gas corrosivi.

## 1.4 Moving

---

In order to avoid any damage to the device during transportation, please keep it in upright position without shaking.

## 1.5 Disposal information

---



Electrical and electronic equipment marked with specific symbol in compliance with 2012/19/EU Directive must be disposed of separately from household waste. European users can hand them over to the dealer or to the manufacturer when purchasing a new electrical and electronic equipment, or to a WEEE collection point designated by local authorities. Illegal disposal is punished by law.

Disposing of electrical and electronic equipment separately from normal waste helps to preserve natural resources and allows materials to be recycled in an environmentally friendly way without risks to human health.

## 2 Introduction

The probe measures the temperature and soil volumetric water content by using a capacitive measurement principle which allows fast measurements in the field and with minimal invasiveness. The volumetric content of water is defined as the ratio between the volume occupied by water in a given portion of soil and the total volume. As a result the measurement can be expressed as a percentage of the water volume with respect to the total volume.

The circuit board is protected inside a housing made of plastic material and sealed with epoxy resin which allows to achieve reliable measurements even in harsh environmental conditions.

The probe is supplied with an RS485 digital output and Modbus-RTU protocol. This solution ensures the use of very long connection cables. The sensor is also supplied with a standard 5m power and signal cable.

### Ordering codes:

RS485 Modbus: ..... PSM-t003m-TRHTC

### 2.1 Technical Specifications

Measurement performance	
Transducer type	Capacitive
Measurement range	0 ÷ 60 VWC
Accuracy (@23°)	± 3 % between 0 and 50% VWC (standard mineral soil, EC < 5 mS/cm)
Measuring volume	∅ = 100 mm x H=150 mm for the 2-electrode probe
Temperatura di lavoro del sensore	-40...+60 °C
Temperature	
Sensor	NTC 10 kΩ @ 25 °C
Measuring range	-40...+60 °C
Resolution	0,1 °C
Accuracy	± 0,5 °C
Long-term stability	0,1 °C / year
Power supply	
	5...30 Vdc for versions with RS485 output and versions with 0.5...3 V analog output
Consumption	
	2 mA average / 15 mA peak @ 12 Vdc

<b>Output</b>	RS485 con protocollo Modbus-RTU
<b>Materials</b>	Handle: thermoplastic material and epoxy resin Electrodes: epoxy glass, thickness 2 mm
<b>Connection</b>	Fixed cable with open wires at the end, length 5 or 10 m standard
<b>Protection degree</b>	IP 67
<b>Weight</b>	150 g approx. (including the 5 m cable)

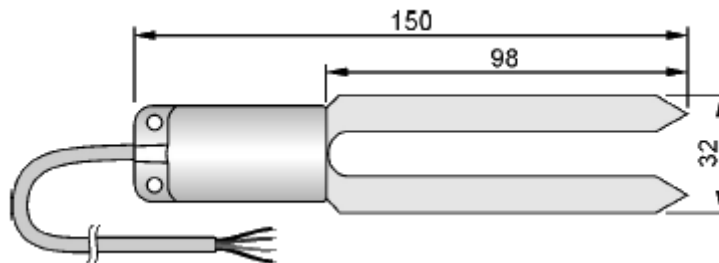

## 2.2 Installation

By means of an accessory, perform a hole into the soil deep enough to accommodate the probe. Never use the probe to make the hole in the soil, in order to avoid mechanical damage to the probe itself.

Once the hole was done, insert the probe completely into the soil so that the entire handle is covered by the ground: the temperature sensor is located inside the handle, close to the electrodes; therefore, it is necessary that the handle is immersed in the soil for a correct detection of the temperature.

After the introduction of the probe, fill in the empty spaces between the soil and the probe with some soil made powder. To obtain accurate measurements, the soil should be in contact with the electrodes and the probe handle.

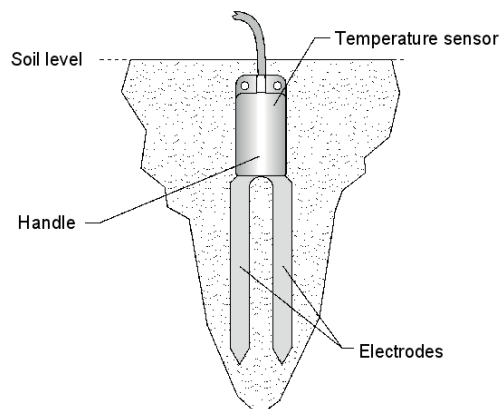

Fig. 2: Installation

The probe can be oriented in any direction, but it is advisable to place it vertically into the ground, so to not hinder the flow of water downward and to minimize the influence of the probe in the soil behavior.

**Warnings:**

- The portion of soil in which the probe is inserted must be uniform, without air gaps, and not too compact as it would make the introduction of the probe difficult.
- Pay attention to the presence of roots, stones or other objects present in the subsurface that may come between the electrodes and affect the measure.
- Do not use excessive force when introducing the probe, so to avoid irreparable damage to the electrodes.
- The probe measures the water content of the soil volume immediately surrounding the electrodes: position the probe so that there are no objects close to the probe, such as metal poles for example, that may affect the field of action of the probe itself.
- Indicate the presence of the probe during the maintenance operations of the soil (e.g.lawn mowing, ploughing, mechanized harvesting, etc.).
- In order to remove the probe from the soil, grab the handle and pull it upwards.During the extraction, remove the probe vertically, by avoiding tilt that would damage the electrodes.
- Do not remove the probe by pulling the cable.

**2.3 Connections**

Wire color	Function
	RS485 output
Black	Negative power supply
Red	Positive power supply
White	RS485 A/-
Green	RS485 B/+

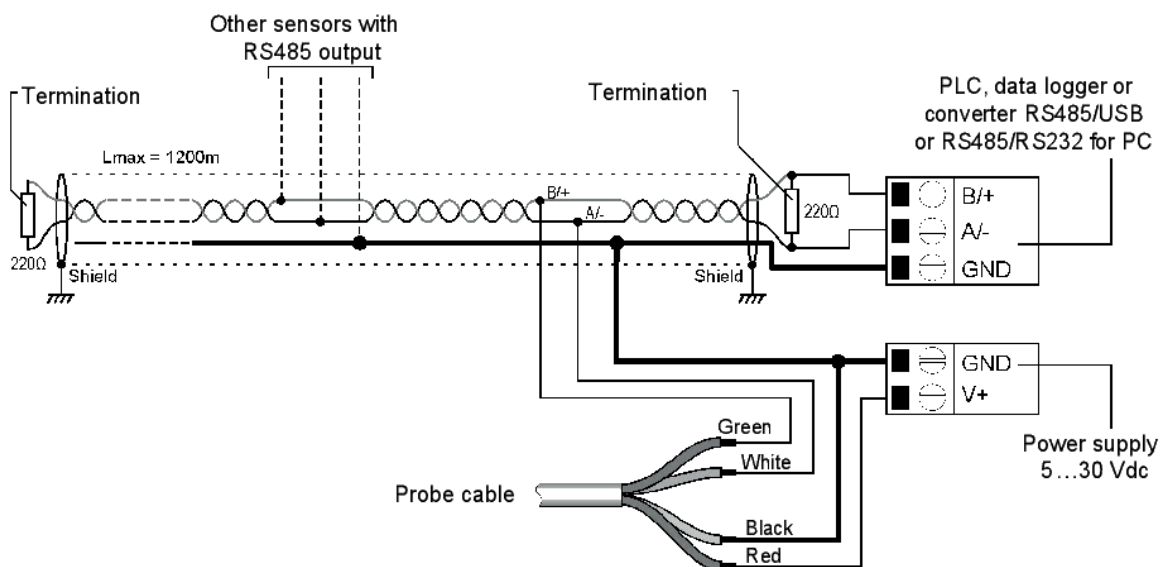

### 2.3.1 Setting of RS485 communication parameters

Before connecting the probe to the RS485 network you must assign an address and set the communication parameters, if different from the factory preset.

The parameter setting is performed by connecting the probe to the PC by using a RS485/USB or RS485/RS232 converter. The probe must be powered separately. If RS485/USB converter is used it is necessary to install the appropriate USB drivers in the PC.

### 2.3.2 Procedure for setting the parameters

1. Start a serial communication program, HyperTerminal for example. Set the communication parameters the same as those set in the instrument. By default, the parameters are:

Baud Rate = 19200

Data Bits = 8

Parity = Even

Stop Bits = 1

In the program, set the number of the COM port to which you connect the probe..

2. Type three times the character | (124 decimal code ASCII character). The probe replies with @.

3. Within 10 seconds from the probe reply, send the command @ (64 decimal code ASCII character followed by the Enter key). The probe replies with &.

Note: if the probe does not receive the @ command within 10 seconds, the Modbus mode is activated again.

4. Send the command CAL USER ON.

Note: the CAL USER ON command is disabled after an inactivity of 5 minutes.

5. Send the following serial commands to set the RS485 MODBUS parameters:

Command	Replay	Description
CMA <sub>nnn</sub>	&	Set address RS485 to nnn Ranging from 1 to 247. Preset on 1
CMB <sub>n</sub>	&	Set RS485 Baud Rate: n=0⇒ 9600, n=1 ⇒ 19200 Preset on 1⇒ 19200
CMP <sub>n</sub>	&	Set RS485 transmission mode (data bits, parity, stop bits): n=0⇒ 8N1, n=1 ⇒ 8N2, n=2 ⇒ 8E1 n=3 ⇒ 8E2, n=4 ⇒ 8O1, n=5 ⇒ 8O2 Preset on 2 ⇒ 8E1
CMW <sub>n</sub>	&	Set receiving mode after RS485 transmission: n=0 ⇒ Violate protocol and go in Rx mode right after Tx n=1 ⇒ Violate protocol and go in Rx mode right after Tx Preset on 1 ⇒ Respect the protocol

### 2.3.3 Modalità ModBus

---

The probe enters RS485 MODBUS-RTU mode immediately after power on..

#### 2.3.3.1 Lettura delle misure

In modalità MODBUS è possibile leggere, mediante il codice funzione 04h (Read Input Registers), i valori misurati. La tabella seguente elenca i registri MODBUS di tipo *Input Registers* disponibili:

MODBUS Input Registers

Numero registro	Indirizzo registro	Dato	Formato
1	0	Status register	16-bit integer
2	1	Volumetric water content in % VWC [x10]	16-bit integer
3	2	Apparent dielectric permittivity [x1000]	16-bit integer
4	3	Soil temperature in °C [x10]	16-bit integer
5	4	Soil temperature in °F [x10]	16-bit integer

#### 2.3.3.2 REGISTRO DI STATO

---

The 16-bit status register gives the following information:

Bit	Descrizione
0	If equal to 1, an error occurred
1	If equal to 1, data memory overflow
2	If equal to 1, data memory error
3	If equal to 1, program memory error
4...5	Always 0
6	If equal to 1, VWC measurement error
7	If equal to 1, temperature measurement error
8	If equal to 1, power cycle
9...14	Always 0
15	If equal to 1, probe not ready (invalid measures)

### 3 **Revision history**

---

The following table shows the description of the changes made to this document.

<b>Version</b>	<b>Date</b>	<b>Updates</b>
1.0	14/02/2025	Current version of the document.

#### **Main contacts**

Tel.: +39 0438 491411

Fax.: +39 0438 401573

Sales Office: [sales@siapmicros.com](mailto:sales@siapmicros.com)

Administrative Office: [finance@siapmicros.com](mailto:finance@siapmicros.com)

Technical Assistance: [service@siapmicros.com](mailto:service@siapmicros.com)

Info: [info@siapmicros.com](mailto:info@siapmicros.com)

All the information content in this document are the current available at the printing phase. Siap+Micros S.p.A. reserve the rights to change the specifications without any advance notice